

**DIRECT SUPPORT AND GENERAL SUPPORT MAINTENANCE MANUAL  
FOR  
HULL, SUSPENSION, AND MISCELLANEOUS HULL COMPONENTS  
OF THE  
ARMORED RECONNAISSANCE/AIRBORNE ASSAULT VEHICLE:  
FULL-TRACKED, 152-MM GUN/LAUNCHER  
M551A1 (2350-00-140-5151)  
AND  
M551NTC (2350-01-115-1579)**

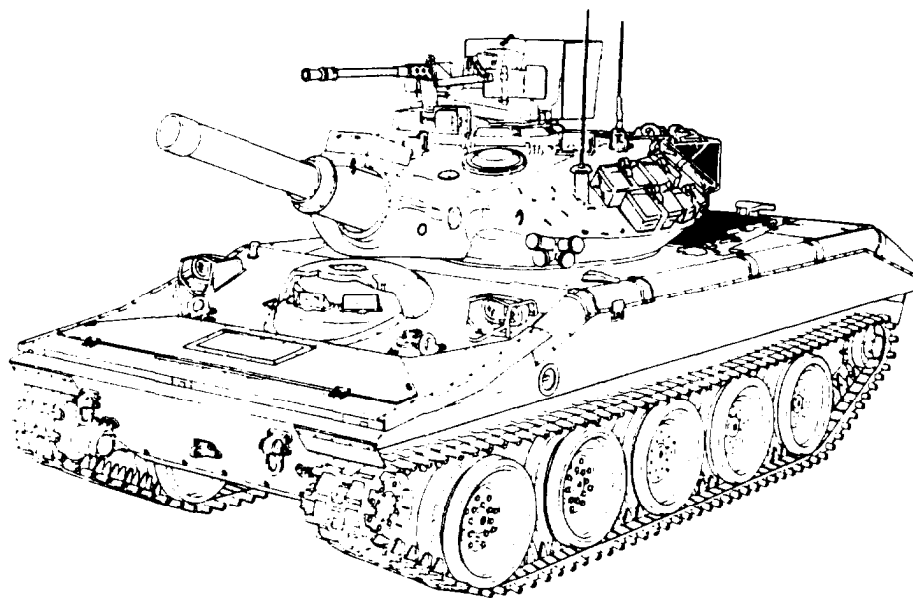

Approved for public release; distribution is unlimited.

---

HEADQUARTERS, DEPARTMENT OF THE ARMY

**August 1978**

**Change 2**

## WARNING

### CARBON MONOXIDE POISONING CAN BE DEADLY

CARBON MONOXIDE IS A COLORLESS, ODORLESS, DEADLY POISONOUS GAS, WHICH, WHEN BREATHED, DEPRIVES THE BODY OF OXYGEN AND CAUSES SUFFOCATION. EXPOSURE TO AIR CONTAMINATED WITH CARBON MONOXIDE PRODUCES SYMPTOMS OF HEADACHE, DIZZINESS, LOSS OF MUSCULAR CONTROL, APPARENT DROWSINESS, AND COMA. PERMANENT BRAIN DAMAGE OR DEATH CAN RESULT FROM SEVERE EXPOSURE.

CARBON MONOXIDE OCCURS IN THE EXHAUST FUMES OF FUEL-BURNING HEATERS AND INTERNAL-COMBUSTION ENGINES AND BECOMES DANGEROUSLY CONCENTRATED UNDER CONDITIONS OF INADEQUATE VENTILATION. THE FOLLOWING PRECAUTIONS MUST BE OBSERVED TO INSURE THE SAFETY OF PERSONNEL WHENEVER THE PERSONNEL HEATER, MAIN OR AUXILIARY ENGINE OR ANY VEHICLE IS OPERATED FOR MAINTENANCE PURPOSES OR TACTICAL USE.

1. **DO NOT** OPERATE HEATER OR ENGINE OR VEHICLE IN AN INCLOSED AREA UNLESS IT IS ADEQUATELY VENTILATED.
2. **DO NOT** IDLE ENGINE FOR LONG PERIODS WITHOUT MAINTAINING ADEQUATE VENTILATION IN PERSONNEL COMPARTMENTS.
3. **DO NOT** DRIVE ANY VEHICLE WITH INSPECTION PLATES, COVER PLATES, ENGINE COMPARTMENT DOORS REMOVED UNLESS NECESSARY FOR MAINTENANCE PURPOSES.
4. **BE ALERT** AT ALL TIMES DURING VEHICLE OPERATION FOR EXHAUST ODORS AND EXPOSURE SYMPTOMS. IF EITHER ARE PRESENT, IMMEDIATELY VENTILATE PERSONNEL COMPARTMENTS; IF SYMPTOMS PERSIST, REMOVE AFFECTED PERSONNEL FROM VEHICLE AND TREAT AS FOLLOWS: EXPOSE TO FRESH AIR; KEEP WARM. DO NOT PERMIT PHYSICAL EXERCISE; IF NECESSARY, ADMINISTER ARTIFICIAL RESPIRATION; OBTAIN MEDICAL TREATMENT. THE BEST DEFENSE AGAINST CARBON MONOXIDE POISONING IS ADEQUATE VENTILATION.

### WARNING

THE M8A3 GAS PARTICULATE FILTER UNIT WILL NOT PROTECT CREW AGAINST CARBON MONOXIDE POISONING.

**CHANGE**  
No. 2

HEADQUARTES  
DEPARTMENT OF THE ARMY  
Washington, D. C., 13 February 1997

**DIRECT SUPPORT AND GENERAL SUPPORT MAINTENANCE  
FOR  
HULL, SUSPENSION, AND MISCELLANEOUS HULL COMPONENTS  
OF THE  
ARMORED RECONNAISSANCE/ AIRBORNE ASSAULT VEHICLE:  
FULL-TRACCKED  
152-MM GUN/LAUNCHER  
M551A1(2350-00-140-5151)  
AND  
M551NTC (2350-01-115-1679)**

TM9-2350-230-34-1 dated 25 August 1978, is changed as follows:

1. Remove old pages and insert new pages as indicated below.
2. New, changes or deleted material is indicated by a vertical bar in the margin of the page,.
3. Added or revised illustrations are indicated by a vertical bar adjacent to the illustration identification number.  
Title changed as above.

**Remove Pages**

i and ii  
1-1 through 1-2  
2-1 through 2-4  
2-15 through 2-18  
3-1 through 3-14  
3-21 and 3-22  
3-53 through 3-76  
3-109 through 3-120  
3-129 and 3-130  
3-133 through 3-168  
3-173 and 3-174  
None  
I-1 through I-3  
Cover

**Insert Pages**

i and ii  
1-1 through 1-2  
2-1 through 2-4  
2-15 through 2-18  
3-1 through 3-14  
3-21 and 3-22  
3-53 through 3-76  
3-109 through 3-120  
3-129 and 3-130  
3- 133 through 3-167  
3-173 and 3-174  
B-1 and B-2  
I-1 through I-3  
Cover

4. File this change sheet in front of the publication for reference purposes.

The correct address for DA Form 2028-2 is:

Commander, U.S. Army Tank-automotive and Armaments Command,  
ATTN: AMSTA-IM-QPIT, Warren, MI 48397-5000.

You may also provide DA Form 2028-2 information to TACOM via datafax or e-mail:

- . TACOM's fax number is DSN 786-6323 or Commercial (810) 574-6323
- . TACOM's e-mail address is [tacom-tech-pubs@cc.tacom.army.mil](mailto:tacom-tech-pubs@cc.tacom.army.mil)

By Order of the Secretary of the Army:

Official:



JOEL B. HUDSON

*Administrative Assistant to the  
Secretary of the Army*

03480

DENNIS J. REIMER  
*General, United States Army  
Chief of Staff*

DISTRIBUTION:

To be distributed in accordance with the initial distribution number (IDN) 371027,  
requirements for TM9-2350-230-34-1.

CHANGE }  
No. 1 }

HEADQUARTERS  
DEPARTMENT OF THE ARMY  
WASHINGTON, DC, 1 May 1981

DIRECT SUPPORT AND GENERAL SUPPORT  
MAINTENANCE MANUAL  
HULL, SUSPENSION, AND  
MISCELLANEOUS COMPONENTS OF THE HULL  
FOR  
ARMORED RECONNAISSANCE/  
AIRBORNE ASSAULT VEHICLE:  
FULL TRACKED  
152 MM GUN/LAUNCHER  
M551 (NSN 2350-00-873-5408)  
AND  
M551A1 (NSN 2350-00-140-5151)

TM 9-2350-230-34-1, 25 August 1978, is changed as follows:

1. Remove old pages and insert new pages as indicated below. New or changed material is indicated by a vertical bar in the margin of the page. Added or revised illustrations are indicated by a vertical bar adjacent to the identification number.

Remove Pages	Insert Pages
i and ii	i and ii
1-1 thru 1-4	1-1 thru 1-4
2-11 and 2-12	2-11 and 2-12
3-1 thru 3-18	3-1 thru 3-18
3-53 and 3-54	3-53 and 3-54
3-71 thru 3-76	3-71 thru 3-76
3-99 and 3-100	3-99 and 3-100
3-107 and 3-108	3-107 and 3-108
A-1 (reverse blank)	A-1/(A-2 blank)
I-3 and authentication	I-3 and authentication

2. File this change sheet in front of the publication for reference purposes.

By Order of the Secretary of the Army:

E.C. MEYER  
General, United States Army  
Chief of staff

Official:

J.C. PENNINGTON  
Major General, United States Army  
The Adjutant General

Distribution:

To be distributed in accordance with DA Form 12-37, Direct and General Support requirements for AR/AAV M551, M551A1, Full Tracked, 152MM.



**DIRECT SUPPORT AND GENERAL SUPPORT  
 MAINTENANCE MANUAL  
 HULL, SUSPENSION, AND  
 MISCELLANEOUS HULL COMPONENTS  
 OF THE  
 ARMORED RECONNAISSANCE/  
 AIRBORNE ASSAULT VEHICLE:  
 FULL-TRACKED  
 152-MM GUN/LAUNCHER  
 M551A1 (2350-00-140-5151)  
 AND  
 M551NTC (2350-01-115-1579)**

**REPORTING ERRORS AND RECOMMENDING IMPROVEMENTS**

You can help improve this manual. If you find any mistakes or if you know of a way to improve the procedures, please let us know. Mail your letter, DA Form 2028 (Recommended Changes to Publications and Blank Forms), or DA Form 2028-2 located in the back of this manual direct to: Commander, U.S. Army Tank-Automotive Command, ATTN: AMSTA-MB, Warren, MI 48397-5000. A reply will be furnished to you.

		<b>Para</b>	<b>Page</b>
<b>CHAPTER 1.</b>	<b>INTRODUCTION</b>		
<b>Section</b>	<b>I.</b>		
	General		
	Scope .....	1-1	1-1
	Maintenance forms and records .....	1-2	1-1
	Calibration .....	1-3	1-2
	Quality assurance/quality control .....	1-4	1-2
	Reporting equipment improvement recommendations .....	1-5	1-2
	<b>II.</b>		
	Description and tabulated data		
	Description .....	1-6	1-2
	Tabulated data .....	1-7	1-2
	Repair parts, special tools, TMDE, and support equipment .....	1-8	1-2
<b>CHAPTER</b>	<b>2.</b>		
<b>Section</b>	<b>I.</b>		
	Service upon receipt of material		
	Inspecting, servicing, installing, and setting up instructions .....	2-1	2-1
	Lubrication .....	2-2	2-1
	<b>II.</b>		
	Troubleshooting		
	Introduction .....	2-3	2-1
	Purpose of troubleshooting .....	2-4	2-1
	General instructions and procedures .....	2-6	2-1
	Special procedures .....	2-6	2-1
	Arrangement .....	2-7	2-1
	<b>III.</b>		
	General maintenance		
	Cleaning, painting, and lubrication .....	2-8	2-4
	General maintenance procedures .....	2-9	2-5
	Welding, general .....	2-10	2-5
	Welding repair of cracked aluminum fuel tanks .....	2-11	2-5
	Specific repair data .....	2-12	2-14
	<b>IV.</b>		
	Removal and installation of major components		
	Scope .....	2-13	2-14
	Detailed references .....	2-14	2-14
<b>CHAPTER 3.</b>	<b>REPAIR OF COMPONENTS AND ASSEMBLIES FOR M551/MM551A1</b>		
<b>Section</b>	<b>I.</b>		
	General		

\*This manual supersedes TM 9-2350-230-35/1, 18 July 1966, including all changes.

	Para	Page
Scope .....	3-1	3-1
Techniques .....	3-2	3-1
II. Repair of power plant		
Scope .....	3-3	3-1
Detailed references .....	3-4	3-1
Operational test .....	3-5	3-1
Stall test .....	3-6	3-1
Engine crankshaft pulley .....	3-7	3-1
Engine mounts.....	3-7.1	3-6.1
Replacement of transmission trunnion cap.....	3-8	3-7
Components of engine and container assembly .....	3-9	3-11
Components of transmission and container assembly .....	3-10	3-12
III. Repair of fuel system components		
Fuel tanks .....	3-11	3-12
Detailed references.....	3-12	3-12
IV. Repair of cooling system components and transmission oil cooler		
Scope .....	3-13	3-15
References .....	3-14	3-15
Fabricated tools for cooling-fan system.....	3-15	3-18
Cooling-fan system (rotor, stator, clutch, retainer bearing, and drive pulley assembly).....	3-16	3-22
Cooling-fan system disassembly-removal of drive pulley .....	3-17	3-26
Cooling-fan system disassembly-removal of clutch from rotor and retainer bearing (and/or clutch and retainer from stator) .....	3-18	3-26
Cooling-fan system disassembly-removal of bearings, lockring, spacer(s) and seal from retainer .....	3-19	3-33
Cooling-fan system assembly-assembly of clutch to rotor.....	3-20	3-39
Cooling-fan system assembly of sealed bearing 1160233 to retainer .....	3-21	3-40
Cooling-fan system assembly-installation of locking 5365-00-999-4291 into retainer .....	3-22	3-41
Cooling-fan system assembly, installation of retainer (with sealed bearing and lockring installed) on fan clutch .....	3-23	3-43
Cooling-fan system assembly-installation of stator using three fabricated alining screws.....	3-24	3-45
Cooling-fan system assembly-preparation for installation of roller bearing MS19078-12 .....	3-25	3-45
Cooling-fan system assembly-installation of roller bearing MS19078-12 and seal 5330-00-930-3108 .....	3-26	3-46
Cooling-fan system-installation of drive pulley.....	3-27	3-49
Functional check-perform functional check.....	3-28	3-52
V. Repair of engine and hull electrical systems		
General .....	3-29	3-53
Removal and installation of engine electrical system wiring harness .....	3-30	3-53
Removal and installation of hull electrical system wiring harness .....	3-31	3-61
Repair of generator drive.....	3-32	3-61
VI. Repair of track and suspension components		
Scope .....	3-35	3-96
Detailed references.....	3-36	3-96
VII. Repair of hull components		
General .....	3-37	3-110
Driver's hood and rotatable hatch .....	3-38	3-110
Surfboard and barrier .....	3-39	3-110
Repair of flotation skin .....	3-40	3-125
Parking brake lock .....	3-41	3-129
Mine protective kit-11652870 .....	3-42	3-129
VIII. Repair of hull accessories		
General .....	3-43	3-129
Hull accessories (bilge pump, personnel heaters and fire extinguishers (recharging)) .....	3-44	3-129
IX. Winterization kit		
General .....	3-45	3-175
Installation of winterization kit .....	3-46	3-175
Repair of coolant heater .....	3-47	3-181
Installation of late winterization kit 11678893 .....	3-48	3-194
CHAPTER 4. FINAL INSPECTION		
General .....	4-1	4-1
Personnel .....	4-2	4-1
Equipment .....	4-3	4-1
Preparation.....	4-4	4-1
Items to inspect .....	4-5	4-1
References.....		A-1
APPENDIX A. Expendable and durable items list.....		B-1
APPENDIX B. INDEX .....		I-1



# CHAPTER 1 INTRODUCTION

## Section I. GENERAL

### 1-1. Scope

a. This manual contains instructions for direct support and general support of hull, suspension, final drive, and miscellaneous components for the Armored Reconnaissance/Airborne Assault Vehicle: Full Tracked, 152mm M551/M551A1 (figs. 1-1 and 1-2).

b. Other pertinent publications applicable to the M551 vehicle are listed in appendix A.

c. Direct support and general support maintenance procedures will be performed in accordance with the maintenance allocation chart (TM 9-2350-230-20-1).

### 1-2. Maintenance Forms and Records

a. *Authorized Forms.* For a listing of all authorized forms, refer to DA Pam 310-2. Maintenance forms and records which you are required to use are listed and explained in TM 38-750.

b. *Field Report Accidents.*

(1) Injury to personnel or damage to materiel (AR 385-40).

(2) Accident or malfunction of ammunition (AR 75-1).

c. *Equipment Improvement Recommendations (EIR's).* Refer to TM 38-750.

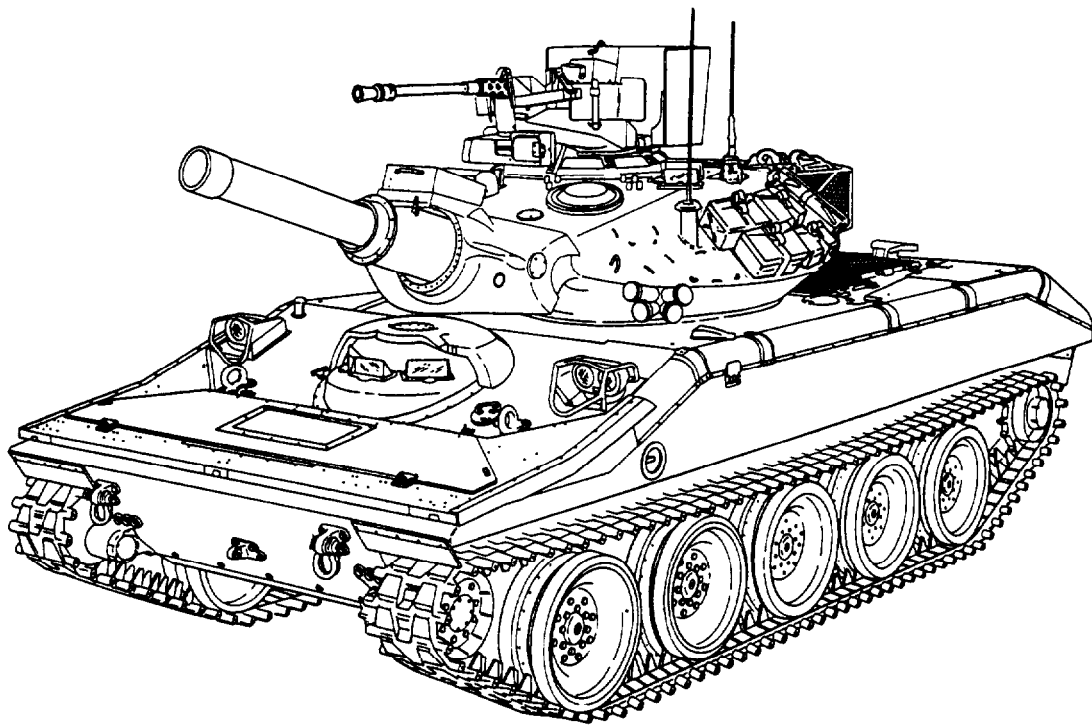

*Figure 1-1. Armored reconnaissance/airborne assault vehicle: full tracked, 152mm M551/M551A1 — left front view.*

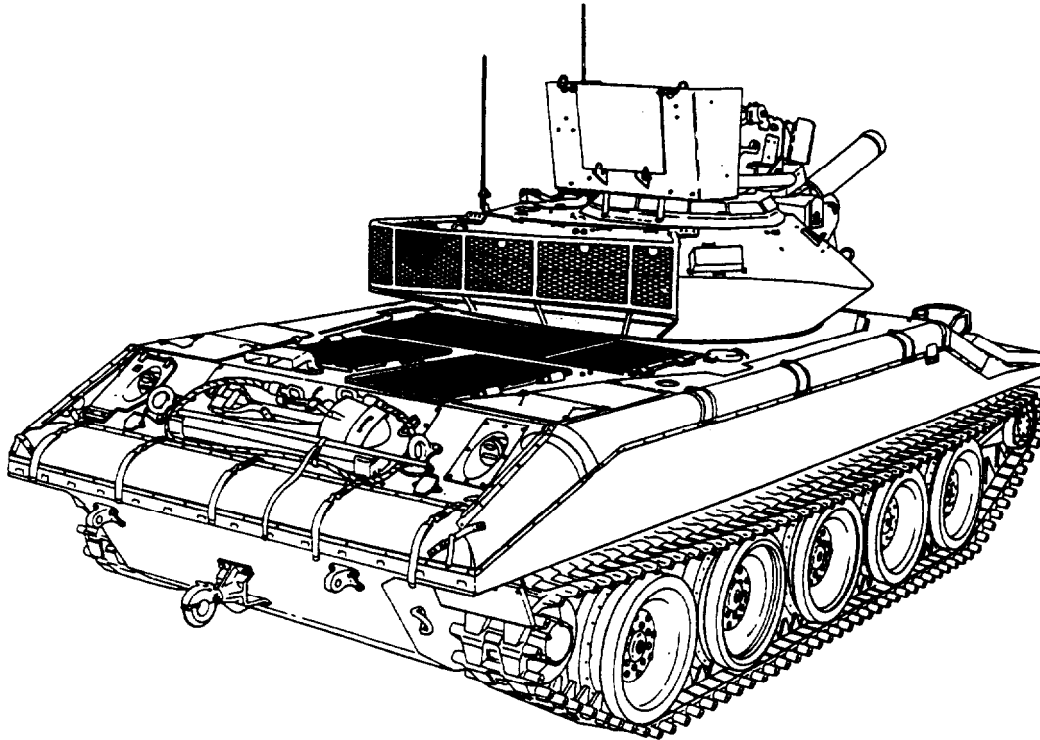

Figure 1-2. Armored reconnaissance/airborne assault vehicle: full tracked, 162mm M551/M551A1 — right rear view.

**1-3. Calibration**

All inspection and test equipment used in conjunction with the vehicle shall be controlled in accordance with requirements of Mil-Std-120, Mil-I-45607, and Mil-C-45662.

**1-4. Quality Assurance/Quality Control**

All parts repaired and/or replaced must conform to the standards published in this manual.

**1-5. Reporting Equipment Improvement Recommendations (EIR)**

EIR can and must be submitted by anyone who is aware of an unsatisfactory condition with the equipment design or use. It is not necessary to show a new design or list a better way to perform a procedure; just tell why the design is unfavorable or why a procedure is difficult. EIR may be submitted on SF368 (Quality Deficiency Report). Mail directly to: Commander, U.S. Army Tank-automotive and Armaments Command, AMSTRA-IM-MCP, Warren, MI 48397-5000. A reply will be furnished to you.

**Section II. DESCRIPTION AND TABULATED DATA**

**1-6. Description**

A description of the M551 Vehicle is contained in TM 9-2350-230-20-1.

**1-7. Tabulated Data**

Data furnished in table 1-1 is supplemental to data contained in TM 9-2350-230-20-1

Table 1-1. Installation References-Hull Items

Installation drawing title	Number	Weight in pounds	Paragraph
Air cleaner	10952493	36	
Hull left ammo rack	10956129	77	
Hull right ammo rack	10956150	68	
Batteries, relay and insulation	10952480	328	
Front bilage pump	11605368	30	3-44a
Rear bilage pump	10955410	43	3-44a
Brake control	11605434	54	
Cooling system	10954304	381	3-13
Driver's hood and rotatable hatch	10954628	533	2-10 and 3-37a

Table 1-1. Installation References - Hull Items - Continued

Installation drawing title	Number	Weight in pounds	Paragraph
Engine, aluminum block	10947063	1120	3-3
Engine, cast iron block	11669078	1440	3-3
Engine electrical	10948679	147	3-29a
Engine exhaust system	10949045	37	
Escape hatch	11644573	142	
Engine mounts	10948435	77	
Final drive shaft	10948876	51	
Fire extinguisher and fuel shutoff control	10955943	72	
Fuel system	11605618	318	2-10 and 3-11
Flotation barrier	10955592	203	3-37a
Headlights	10955329	34	
Hull assembly (complete)	11605220	7357	
Hull electrical	10948730	74	3-29a
Hull stowage	11594022	30	
Ground intercom door	10955870	7	
Land steer control	10949116	17	
Personnel heater	11605663	47	3-44b
Water steer shift control	11593477	8	
Power plant w/aluminum engine block	10948700	2611	3-3
Power plant w/cast iron engine block	10948700	2931	3-3
Shift control	11593544	11	
Surfboard	11605558	239	3-39
Suspension	10948525	7323	3-35
Taillights	10955691	10	
Accelerator and throttle controls	11605433	15	
Trans. oil cooler hoses	10948645	10	
Winterization kit	10955778 11678893	59	3-45a
Transmission	8356300	1316	3-3

**1-8. Repair Parts, Special Tools, TMDE, and Support Equipment**

- a. Special Tools and Equipment Refer to table 1-2 and TM 9-2350-230-24P/1.
- b. Spares and Repair Parts. Authorized repair parts are listed in TM 9-2350-230-24P/1.
- c. Common Tools and Equipment Standard tools and equipment are authorized by tables of allowances

(TA) and tables of organization and equipment (TOE).  
 d. Improvised Tool. A stand, illustrated in figure 1-8, used to support the power plant may be fabricated locally by shops if they are engaged in repairing a number of identical components.

**NOTE**

Improvised tools are not available for issue.

Table 1-2. Special Tools and Equipment

Item and identifying number	Paragraph	Figure	Use
Handle 5120-00-034-0884 (10914146)	3-35 and 3-36	3-81 and 3-82	Used with remover end replacers 5120-00-906-1058, 5120-00-907-1059, and replacer 5120-00-907-0697.
Remover and Replacer 5120-00-906-1059 (10954003-2)	3-35 and 3-36	3-81 and 3-82	Used with handle 5120-00-034-0884 to install roadwheel arm support housing inner bearing and to remove idler wheel hub bearing cup.
Remover and Replacer 5120-00-906-1058 (10954003-3)	3-35	3-81	Used with handle 5120-00-034-0884 to install roadwheel arm support housing outer bearing.
Remover and Replacer 5120-00-119-5244 (10922980)		3-81	To remove and install bearings in track hydraulic adjuster.
Replacer 5120-00-907-0697 (10954001)	3-36	3-82	Used with handle 5120-00-034-0884 to install inner and outer bearing cups in idler hub.
Tool, Stall Check 4910-00-907-0703 (8355989)	3-6	3-5	To stall check engine and/or transmission with power plant removed from vehicle.
Spanner Wrench NSN 5120-00-907-0698	3-17	3-21	Used in the removal/installation of the cooling fan system.
Open-end, Adjustable Wrench 5120-00-449-8084	3-17	3-21	Used in the removal/installation of the cooling fan system.

Table 1-2. Special Tools and Equipment - Continued

Item and identifying number	Paragraph	Figure	Use
Puller Kit NSN 5120-00-423-1596	3-18	3-27	Used in the removal/installation of the cooling fan system.
Heavy Duty Special Pliers NSN 5120-00-293-0186	3-19	3-32	Used in the removal/installation of retaining rings.
Torque Wrench NSN 5120-00-247-2540 or NSN 5120-00-640-6364	3-20	3-34	Used in the removal/installation of the cooling fan system
Socket Wrench 7/8-inch HD NSN 5130-00-227-6677	3-27	3-47	Used in torquing operation after heated pulley is positioned on clutch.
Impact Socket NSN 5130-00-449-7698	3-27	3-47	Used in torquing of multipiece pulley.
Torque Wrench NSN 5120-00-247-2536	3-27	3-47	Used in torquing of multipiece pulley.
Torque Wrench NSN 5120-00-221-7983	3-27	3-47	Used in torquing of multipiece pulley.

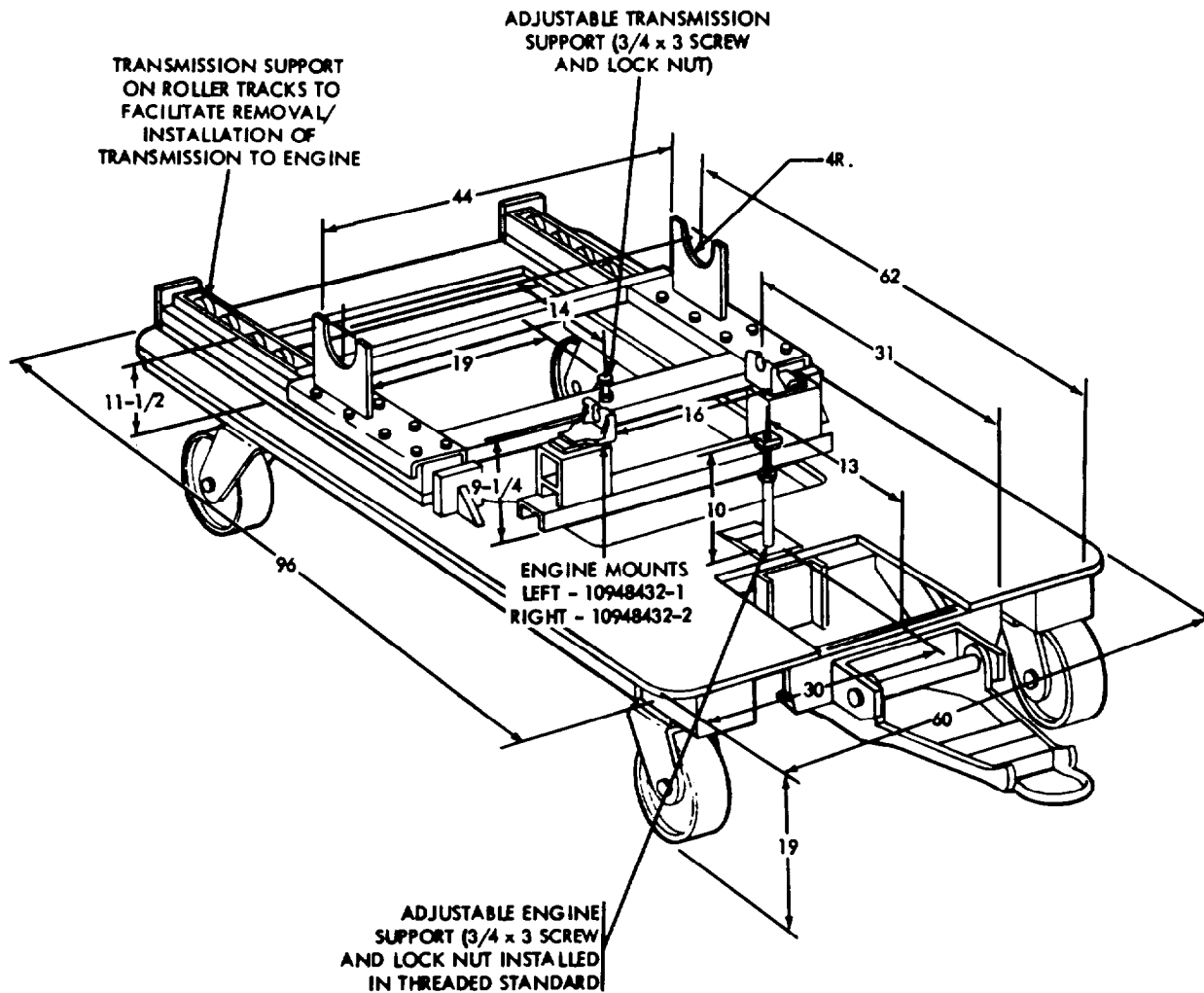

ORD E70484

Figure 1-3. Power plant stand (improvised).

**CHAPTER 2  
MAINTENANCE INSTRUCTIONS**

**Section I. SERVICE UPON RECEIPT OF MATERIEL**

**2-1. Inspecting, Servicing, Installing, and Setting-up Instructions**

- a. Inspect all assemblies, subassemblies, and accessories to be sure they are properly assembled, secured, cleaned, correctly adjusted, and lubricated.
- b. Thoroughly clean all parts coated with rust pre-

ventive compound. Use drycleaning solvent (SD).

**2-2. Lubrication**

Lubrication Order LO 9-2350-230-12 prescribes lubricating procedures, intervals, and proper materials for this vehicle.

**Section II. TROUBLESHOOTING**

**2-3. Introduction**

a. This section contains the troubleshooting information for locating and correcting most of the operating troubles which may develop in the M551/M551A1 vehicles. Each malfunction for an individual component, unit, or system is followed by a list of tests or inspections which will help you to determine the corrective actions for you to take. You should perform the tests/inspections and corrective actions in the order listed.

b. This manual cannot list all possible malfunctions that may occur, nor all tests or inspections and corrective actions. If a malfunction is not listed (except when malfunction and cause are obvious), or is not corrected by listed corrective actions, notify your supervisor.

**2-4. Purpose of Troubleshooting**

Information in this section is to be used in conjunction with and as a supplement to the troubleshooting in TM 9-2350-230-20-1, and provides continuation of instructions where a remedy in TM 9-2350-230-20-1 refers to supporting maintenance personnel for corrective action.

**2-5. General Instructions and Procedures**

- a. Visually inspect deadlined vehicles before any operation to avoid additional damage to components or possible injury to personnel.
- b. Operate components manually, where possible, to

determine normal or abnormal function.

c. Inspect for dents, cracks, bent or broken tubes or parts, moisture, corrosion, dirt, foreign matter, excessive wear, oil stains, bare wires, worn insulation or signs of tampering.

d. Check for completeness of components and equipment.

e. Inspect for authorized or required modifications.

f. Use test equipment or test procedures to determine source of trouble whenever test equipment is available and test procedures have been established.

**2-6. Specific Procedures**

a. Upon completion of general troubleshooting procedures, perform specific procedures described in table 2-1.

b. Operational malfunctions traced to internal components of the engine or transmission may be further isolated by referring to the troubleshooting sections of the engine manual (TM 9-2815-205-34) and transmission manual (TM 9-2520-249-34).

c. Refer to paragraph 3-34e and table 3-10 for test procedures covering the generator voltage regulator.

**2-7. Arrangement**

Table 2-1 consists of a list of malfunctions, the tests or inspections necessary to locate or verify each malfunction, and the corrective action needed to remedy each malfunction.

*Table 2-1. Troubleshooting*

MALFUNCTION	TEST OR INSPECTION	CORRECTIVE ACTION
-------------	--------------------	-------------------

**ENGINE  
NOTE**

A complete troubleshooting table for the 6V53T engine is contained in TM 9-2815-205-34.

**1. STARTER WILL NOT ROTATE**

Inspect for faulty starter or solenoid.

Repair or replace starter or solenoid

**2. ENGINE CRANKS BUT FAILS TO START.**

Step 1. Check for insufficient fuel caused by leak in tank or fuel lines.

Tighten fuel line connections and/or repair or replace fuel tank (figs. 2-3 and 2-9).

Step 2. Injector racks not in full fuel position.

Adjust, repair, or replace linkages and/or fuel injectors (TM 9-2815-205-34).

Table 2-1. Troubleshooting - Continued

MALFUNCTION	TEST OR INSPECTION	CORRECTIVE ACTION
ENGINE - Continued		
	Step 3. Defective air-blower drive.	Repair or replace air-blower drive (TM 9-2815-205-34).
3. UNEVEN OPERATION, FREQUENT STALLING OR ROUGH IDLE.	Check for low coolant temperature.	Fan drive clutch in lockup. Release lockup clutch or replace clutch lockup springs (figs. 3-22 through 3-27).
4. ENGINE OVERHEATS	Check fan drive clutch for operation.	Repair or replace fan clutch (figs. 3-22 through 3-27).
TRANSMISSION		
(For transmission troubleshooting, refer to TM 9-2520-249-34).		
ELECTRICAL SYSTEM		
5. NO BATTERY POWER.	Step 1. Deleted.	
	Step 2. Deleted.	
	Step 3. Check for defective generator drive.	Repair or replace generator drive (figs. 3-64 through 3-66).
	Step 4. Check for locked out voltage regulator failsafe circuit	Momentarily disconnect battery to reset voltage regulator failsafe circuit.
6. BATTERY ELECTROLYTE BOILS.	Check for high generator voltage.	Troubleshoot generator circuit (refer to TM 9-2350-230-20-1).
7. Deleted.		
TRACKS AND SUSPENSION		
8. GREASE LEAKS FROM ROADWHEEL ARM SUPPORT HOUSING.	Check for defective inner or outer seal.	Replace seals.
9. SUPPORT HOUSING OVERHEATS	Step 1. Check for proper lubrication.	Lubricate in accordance with LO 9-2350-230-12.
	Step 2. Check for seized bearings or spacer.	Replace bearings and/or spacer (refer to TM 9-2350-230-20-1).
	Step 3. Check for proper assembly of bearings in housing.	Readjust or replace bearings (refer to TM 9-2350-230-20-1).
10. TRACK WILL NOT ADJUST PROPERLY.	Step 1. Check for defective seals in hydraulic track adjuster.	Replace seals.
	Step 2. Check for seized piston in hydraulic track adjuster cylinder.	Repair or replace track adjuster (fig. 3-83).
	Step 3. Check for binding of idler spindle in housing.	Repair or replace idler assembly (fig. 3-86).

Table 2-1. Troubleshooting - Continued

MALFUNCTION	TEST OR INSPECTION	CORRECTIVE ACTION
TRACKS AND SUSPENSION - Continued		
11. VEHICLE SAGS TO ONE SIDE.		<ul style="list-style-type: none"> <li>Check for defective bearings in roadwheel arm support housing.</li> <li>Replace bearings in support housing (refer to TM 9-2350-230-20-1).</li> </ul>
PERSONNEL HEATER		
12. HEATER FAILS TO START WHEN CONTROL SWITCH IS TURNED ON.	Step 1. check for electric current to heater.	Tighten any loose connections in control box.
	Step 2. Check for defective ignition control.	Tighten motor lead wire connections and any other loose wiring connections.
	Step 3. Check solenoid on fuel control valve for proper operation.	Replace valve.
	Step 4. Check for open circuit in overheat switch.	Replace switch.
	Step 5. Check for defective flame detector switch.	Replace switch.
	Step 6. Check vaporizer or wick.	If wick is short or burned, replace wick.
	Step 7. Check burner assembly.	Remove carbon and soot from burner.
13. HEATER OVERHEATS AND STOPS BURNING.	Check for defective fuel control valve.	If solenoid does not open when power is applied, replace fuel control valve.
14. HEATER OVERHEATS BUT CONTINUES TO BURN.	Check for defective overheat switch.	Replace switch.
15. HEAT OUTPUT TOO LOW.	Check for defective fuel control valve.	Replace control valve.
16. HEATER SMOKES EXCESSIVELY OR "BANGS" UPON STARTING.	Check for leaking fuel control valve.	Replace fuel control valve.
17. BLOWER WILL NOT STOP WHEN HEATER IS TURNED OFF.	Check for defective detector switch. Back off adjusting screw about two turns. (Must be done with heater and/or switch cold.) Turn the adjusting screw inward until the switch just "clicks" and then turn inward an additional 3/4-inch turn from the click position.	Replace switch if above procedure fails to correct malfunction.
18. ODOR OF FUEL IN VENTILATING AIR STREAM.	Check for leaking fuel at burner fuel tube or fuel control valve.	Tighten fuel connections.
19. BLOWER RUNS BUT HEATER FAILS TO IGNITE AT LOW AMBIENT TEMPERATURE.	Step 1. Check for defective heating element in fuel control valve.	Tighten all electrical connections and tighten ground lead. If element has power and does not heat, replace fuel control valve.
	Step 2. Check for defective ignition control.	If there is power at the ignition control unit and does not ignite, replace ignition control unit.
	Step 3. Check for low voltage.	
20. HEAT EXCHANGER BECOMES LOADED UP WITH SOOT AND CARBON.	Step 1. Check for slow motor.	Tighten all elected connections or replace motor.
	Step 2. Check for high fuel rate.	Check fuel flow in accordance with paragraph 3-44e(6).

Table 2-1. Troubleshooting- Continued

MALFUNCTION	TEST OR INSPECTION	CORRECTIVE ACTION
<b>PERSONEL HEATER - Continued</b>		
		Change to suitable grade of fuel oil.
Step 3.	Check for low Voltage.	Voltage must be 24V DC at source.
Step 4.	Check for back pressure caused by exhaust in area with higher pressure than heater inlet.	Correct position so that exhaust is at same or lower pressure than inlet.
<b>BILGE PUMP</b>		
21.	FRONT BILGE PUMP HOES NOT OPERATE WHEN SWITCH AND INDICATOR LIGHT IS ON.	Check for defective bilge pump. Repair or replace bilge pump (figs. 3-106 through 3-108).
22.	ONLY ONE REAR BILGE PUMP OPERATES.	Check for defective bilge pump. Repair defective bilge pump (figs. 3-106 through 3-108).
<b>. WINTERIZATION KIT COOLANT HEATER</b>		
23.	HEATER RUNS BUT HEATER WILL NOT IGNITE.	Step 1. Check for defective igniter. If igniter fails to heat, when voltage is applied, replace igniter.
	Step 2. Check for defective preheat resistor.	Replace preheat resistor.
	Step 3. Check for excessive carbon in heat exchanger and/or burner.	Scrape residue and all soot or carbon away from inside the pocket and other burner surfaces including the fuel feed bushing.
24.	HEATER STARTS AND RUNS BUT GOES OUT LATER.	Check for restriction in coolant flow. Remove restriction.
25.	HEATER OVERHEATS.	Step 1. Check for defective fuel control valve. Replace fuel control valve.
	Step 2. check for restriction in coolant flow.	Remove restriction.
26.	LOW HEAT OUTPUT.	Check for defective fuel control valve. Replace fuel control valve.
27.	HEATER BURNS CONTINUOUSLY ON HIGH HEAT.	Check for defective diode. Replace diode.
28.	HEATER BURNS CONTINUOUSLY ON LOW HEAT.	Check for defective diode. Replace diode.
29.	BLOWER WILL NOT STOP WHEN HEATER IS SHUT OFF.	Check for improperly adjusted or damaged flame detector switch. Adjust switch (fig. 3-113) or replace switch if ceramic rod is broken.

**Section III. GENERAL MAINTENANCE**

**2-8. Cleaning, Painting, and Lubrication**

*a. Cleaning*

(1) General. Refer to TM 9-247 for instructions on equipment and materials to be used.

(2) Cleaning of materiel received from storage.

(a) Materiel received by supporting maintenance units from storage will be cleaned by the dip

tank, vapor-degreaser, or steam method, whichever is applicable or available.

(b) If some time is to elape before the start of repair or overhaul operations, apply a coating of light grade preservation oil to all finished metal surfaces to prevent rusting.

*b. Ball and Roller Bearings.* Refer to TM 9-214 for



cleaning, inspection, and lubrication of bearings, and instructions for evaluation of bearing life.

c. Painting

(1) Clean and repaint all surfaces deteriorated or damaged. When repainting individual components after repair, all existing paint must be renewed.

(2) Do not paint electrical harnesses or leads.

(3) Prime paint interior surfaces, and hull exterior in accordance with TT-P-666.

(4) Paint inside of battery box with acidresistant paint.

(5) Apply coat of white semi-gloss enamel to interior of hull.

(6) Paint walkways on hull exterior with olive drab No. X24087, non-slip Type II, MILD-23003. All remaining exterior surfaces will be painted olive drab in accordance with TT-E-529.

(7) Refer to TM 9-2350-230-20-1 for application of stencil markings to vehicle.

d. Lubrication Refer to LO 9-2350-230-12 for lubrication instructions.

## 2-9. General Maintenance Procedures

a. Disassembly and Assembly Procedures.

(1) Keep disassembly operations to the minimum required for repair or replacement.

(2) Tag critical parts such as shims, bearings, and electrical harnesses and leads, to facilitate reassembly.

(3) Mark gears on mating teeth by scribe marks, dye, indelible ink, or paint.

**CAUTION**

Never scribe-mark bearing surfacea.

(4) Records to provide repair and replacement data and statistics should be carefully prepared and maintained, according to DA Form 2408 and DA Form 2409.

b. Replacement of Parts.

(1) Replace keys, screws, washers, or nuts that are

damaged.

(2) Replace all gaskets, packings, O-rings, and seals at assembly or installation.

(3) Replace springs if broken, kinked, cracked, or do not conform to standards.

(4) New lock wire will be used whenever lock wire is required.

c. Repairing Damaged Threads.

(1) When determined feasible by inspection, damaged threads should be repaired by retapping, or by "chasing" with a used die or tap.

(2) Tapped holes for screw thread inserts that have mutilated threads may be repaired by:

(a) Drilling and tapping hole oversize and installing large inserts.

(b) Filling tapped hole by welding, redrilling, and tapping hole to original size.

d. Removing Burs, Scratches, and Raised Metal.

(1) Use fine mill file, soft stone, or crocus cloth dipped in drycleaning solvent to remove burs and scratches.

(2) When filing aluminum, clean file with steel file brush to avoid loading file with aluminum particles which will gouge work surfaces.

## 2-10. Welding, General

a. Refer to TM 9-237 for general welding instructions and materials.

b. Refer to figures 2-1 through 2-6 for aluminum welding supplement instructions.

**CAUTION**

Vehicle interior must be thoroughly cleaned of all traces of fuel and oil and properly ventilated prior to extensive interior and exterior welding. Remove fuel tanks and engine as necessary. Remove hull drain access plugs; clean floor with solvent and flush with water.

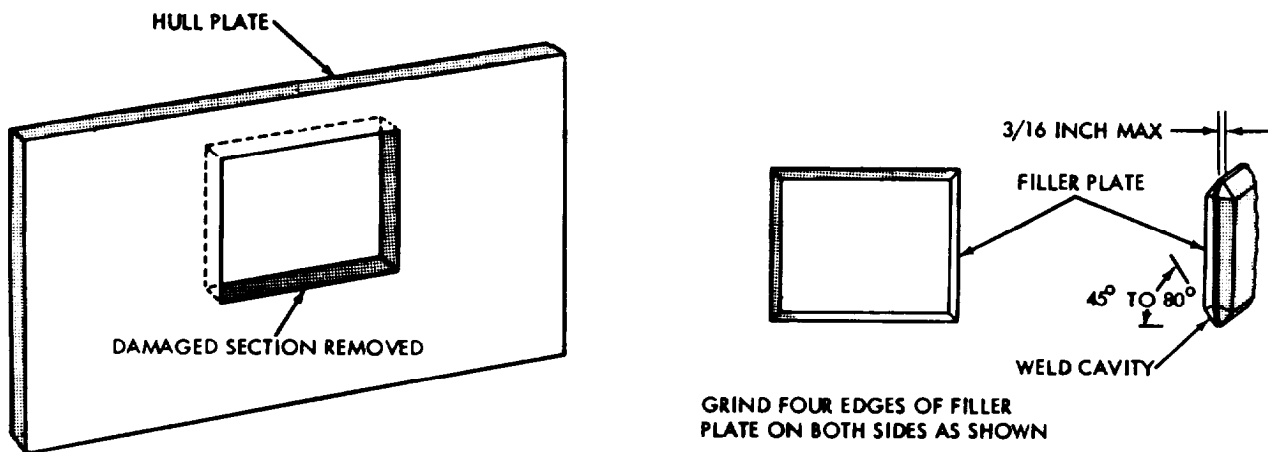

**NOTE. WHEN WELDING IN FILLER PLATE, ALTERNATE PASSES FROM ONE SIDE TO OTHER SIDE.**

ORD E70499

Figure 2-1. Filler plate details.

## 2-11. Welding Repair of Cracked Aluminum Fuel Tanks

### a. Procedure.

(1) This repair procedure pertains only to M551 fuel tanks which have leaks caused by cracks.

(2) All cracks backed by interior fuel splash panel gussets (Drawing Number 10952617, Section J-J) shall require a special procedure. This special procedure is listed separately in (d) below.

### b. Special Equipment and Materials Required for Repair.

#### (1) Grinders.

(a) Pencil grinder or equivalent, with 1/4 to 1/2-inch rotary file.

(b) Pneumatic grinder capable of grinding welds flush with base metal

(2) Gas metal arc or gas tungsten arc welding equipment.

(3) Filler metal

(a) QQ-R-566, type MIL-5356, 1/8-inch diameter.

(b) MIL-E-16053, type MIL-5356, .030 or .045 diameter.

(4) Shielding gas. 100% argon.

(5) Dye-Penetrant and developer, penetrant, NSN 6850-00-062-8320, cleaner, NSN 6850-00-062-8315, developer, NSN 6850-00-845-4265.

(6) Cleaning equipment. Capable of thoroughly cleaning interior of fuel tank, TB 750-1047.

(7) Gas analyzer. Determine if volatile air and fuel mixture is present in tank before welding and grinding.

(8) Pressure plate heads and gaskets. For sealing off tank for pressure testing.

(9) Compressed air supply with regulator.

(10) Pneumatic stainless steel wire brush.

### c. Preparation and Reclamation for Weld Repair of Exterior Cracks in M551/M5851A1 Fuel Tanks.

(1) Thoroughly clean interior of fuel tanks according to the procedure listed in TB 750-1047.

(2) Visually inspect fuel tank for cracks and previous epoxy repairs. Pressurize tank to 3 psi air pressure and check for leaks utilizing a soap solution applied to all weld joints.

(3) Immediately prior to grinding, the fuel tanks shall be checked in accordance with TB 750-1047 for volatile air and fuel mixtures.

(4) Remove all epoxy from previous repair areas.

(5) Grind V-groove joint configuration in cracked area, allowing a 1/16-inch to 1/8-inch root opening. Assure that crack is completely ground out through the thickness of the base metal.

(6) Thoroughly remove all paint and primer from area surrounding the ground area utilizing a rotary stainless steel wire brush.

(7) Immediately prior to welding, check fuel tank for volatile fuel air mixtures in accordance with TB 750-1047.

(8) Repair weld in accordance with MIL-W-45205, Class A. Utilize filler metal type 5356 in accordance with MIL-E-16053 or QQ-R-566 (Mig and Tig respectively).

(9) Repair welds shall be ground flush with base metal.

(10) After repair, pressurize tank to 6 psi and determine if any leakage is present, using a soap solution applied to all of the joints. Where leakage is present, repair using the procedure previously listed.

(11) All repair welds shall be strengthened with the addition of 1/8-inch aluminum alloy 5083 or 5086 plate contoured to fit repairs and surrounding areas. See figure 2-2 for examples. The only exception will be where there is interference with fuel tank mounting.

(12) Welding shall be in accordance with MIL W-45205, Class A. Use filler metal type MIL-5356 according to specification MIL-E-16053 or QQ-R-566.

(13) Stress relieve entire fuel tank in accordance with Drawing Number 10893640, except step 3, which is as follows:

(a) Place fuel tank on support or fixture and place in furnace. Furnace temperature may range from ambient to 125°F. maximum.

(b) Heat fuel tank to 450°F. Hold for one hour.

(c) Shut off furnace. Open furnace doors and

cool fuel tank to 200°F.

(d) Remove fuel tank from furnace on support or fixture and cool to room temperature.

(14) Pressurize tank to 6 psi and check for leaks utilizing a soap solution. All weld joints shall be checked including repair welds.

(15) Any leakage present shall be repaired utilizing the above procedure with the exception of stress relieve.

d. Exterior Fuel Tank Cracks Backed by Interior Fuel Splash Panel Gussets.

(1) Thoroughly clean interior of fuel tanks in accordance with the procedure listed in TB 750-1047.

(2) A small section of the fuel-tank wall adjacent to the crack shall be cut out to determine if interior gusset is cracked.

(3) If gusset shows no signs of cracking, replace shall cutout section with an equivalent thickness of 5086 or 5083 aluminum. Weld aluminum section in accordance with specification MIL-W-45205, Class A. Utilize filler metal type MIL-5356 in accordance with specifications MIL-E-16053 or QQ-R-566.

(4) Follow the welding procedure listed previously for repair of exterior fuel tank cracks.

(5) If gusset is found to be cracked, cut out a large enough section of fuel cell wall adjacent to the exterior wall crack to permit grinding and welding of the interior gusset.

(6) Grind V-groove joint configuration in cracked portion of gusset, assuring complete crack removal.

(7) Weld in accordance with specification MIL W-45205, Class A. Utilize filler metal type 5356 in conjunction with specifications MIL-E-16053 or QQ-RR-566.

(8) If crack initiated through a radius portion of gusset, grind weld to match radius contour of gusset.

(9) Replace section of fuel cell wall with an equivalent thickness of 5986 or 5083 aluminum.

(10) Weld replaced section in accordance with MIL-W-45205, Class A. Use filler metal type 5356 in accordance with specifications MIL-E-16053 or QQ-R-566.

(11) Follow the procedure previously listed (repair of exterior cracks in the M551/M551A1 fuel tank) for repair of the cracked fuel-cell wall.

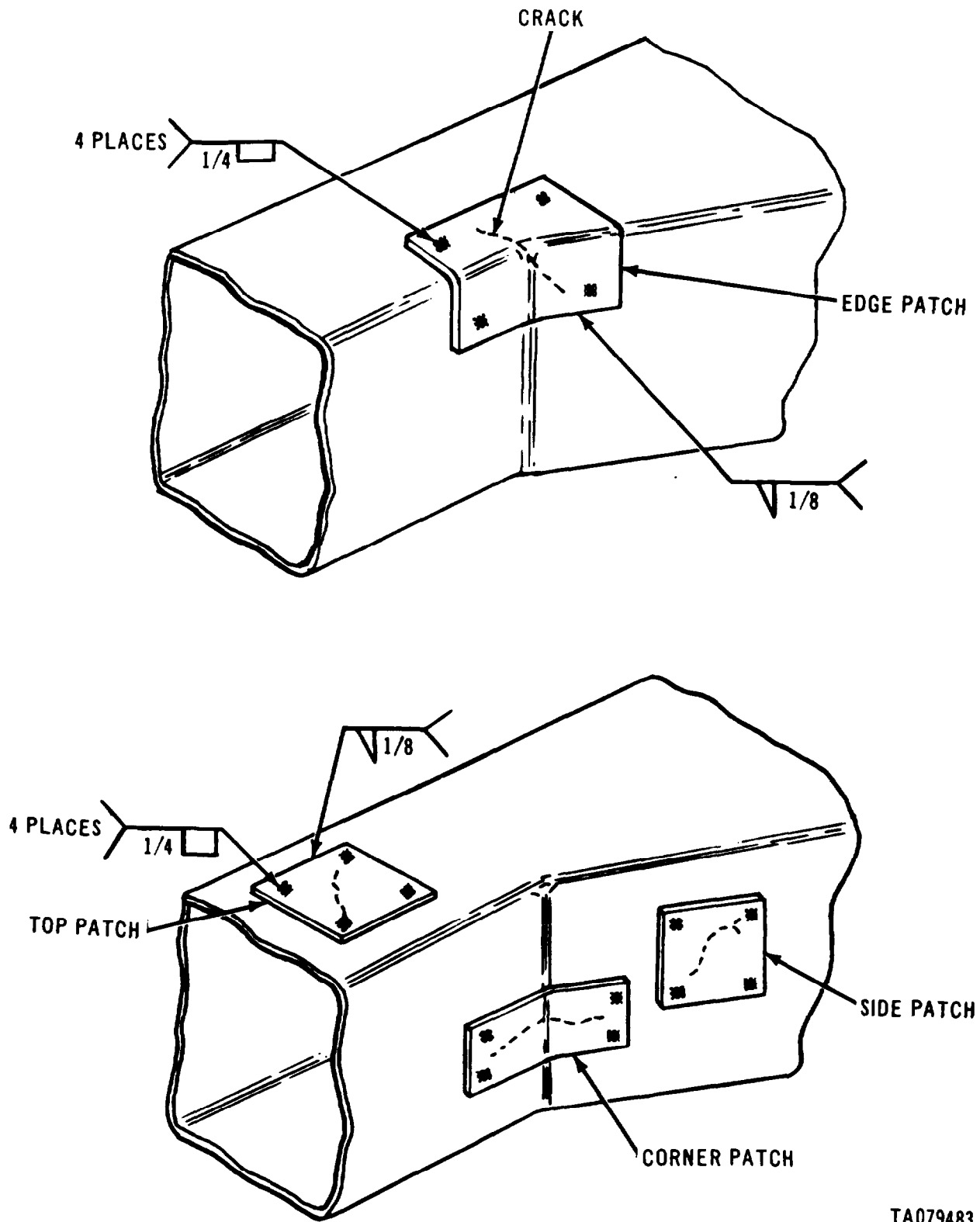

TA079483

Figure 2-2. Weld patches for fuel tanks.

Table 2-2. Fuel Tank Welding Data (TIG Welding Process)

Base Metal Reference. . . . . ALUMINUM ALLOY TYPE 5086-5083-6061

Filler Metal Reference. . . . . TYPE 5356 - SPEC. MIL E-16053

Shield Gas Composition . . . . . ARGON

Shield Gas Flow . . . . . 15 - 20 C.F.H.

Gas Cup Size . . . . . 3/8-inch or 7/16-inch I.D.

Tungsten Type and Size . . . . . 1/16-inch or 3/32-inch DIA.

Joint Preparation. . . . . 1/8-inch ROOT RADIUS - 60° INCLUDED ANGLE

Preweld Cleaning. . . . . CHEMICAL CLEAN OR STAINLESS STEEL WIRE BRUSH

Welding Positions . . . . . FLAT AND HORIZONTAL

Power Source (AC, DC, Polarity). . . . . AC HIGH FREQUENCY

Welding Current & Arc Voltage Range. . . . . 90-150 AMPS - 18-26 VOLTS

Welding Process. . . . . T.I.G. (GAS TUNGSTEN ARC WELD) (MANUAL)

Pass	Filler metal size	Type of pass	Location and sequence of passes
All	1/4-inch or 3/32-inch Diameter	Bead	Clean each weld bead prior to subsequent beads.

Table 2-3. Fuel Tank Welding Data (MIG Welding Process)

Base Metal Reference. . . . . ALUMINUM ALLOY TYPE 5086-5083-6061

Filler Metal Reference. . . . . TYPE 5356 - SPEC. MIL E-16053

Shield Gas Flow. . . . . 30 - 40 C.F.H.

Table 2-3. Fuel Tank Welding Data (MIG Welding Process - Continued)

Electrode Size . . . . . .030 inch or 3/16-inch DIA.

\* Joint Preparation . . . . . Groove 60° INCLUDED ANGLE

Preweld Cleaning. . . . . STAINLESS STEEL WIRE BRUSH AND WIPE WITH A CLEAN RAG SATURATED WITH CLEANING SOLVENT

Welding Position . . . . . FLAT AND HORIZONTAL

Power Source. . . . . DC REVERSE POLARITY

Welding Current and Arc Voltage Range . . . . . 120 - 15 AMPS: 20 - 24 VOLTS

Welding Process. . . . . GMAW (GAS METAL ARC WELDING) (MANUAL)

Arc Travel Speed. . . . . 24 - 30 inches PER MINUTE

CAUTION

Determine if volatile mixture is present in tank before grinding and welding with explosive meter such as MSA Explosion Meter, NSN 6665-00-664-4650 (Reference TB 750-1047). If present, clean interior according to procedure listed in TB 750-1047.

Pass	Filler metal size	Type of pass	Location and sequence of passes
All	0.030 inch or 3/64-inch Diameter	Bead	

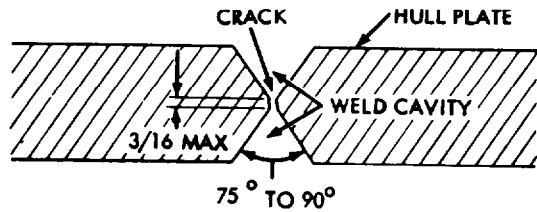
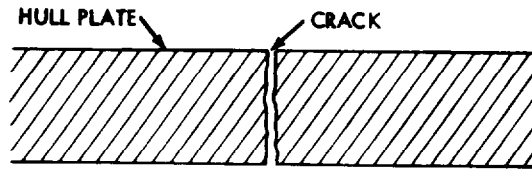

A - TYPICAL WELD CAVITY

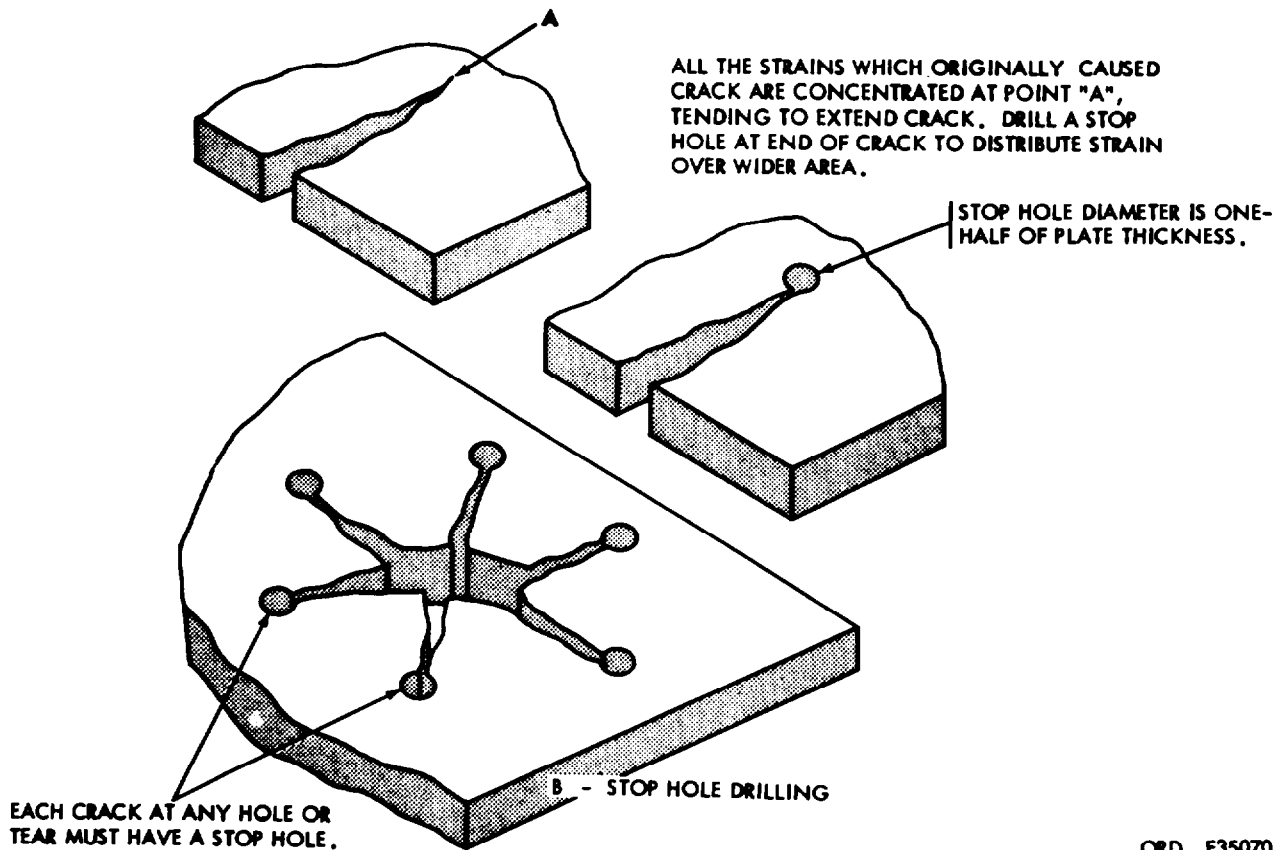
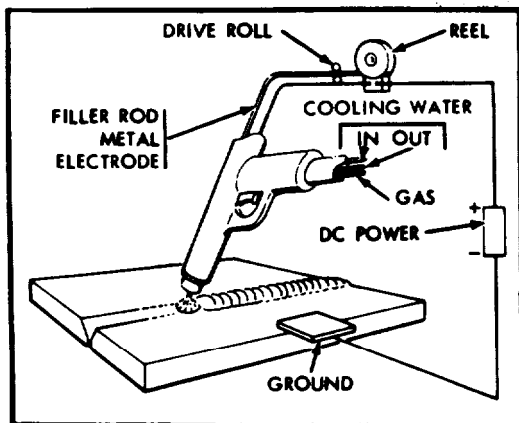

Figure 2-3. Stop hole drilling and typical weld cavity.

ORD E35070



MIG (METAL-INERT-GAS) PROCESS

1. THE "MIG" (METAL-INERT-GAS) PROCESS UTILIZES A DC POWER SOURCE, CONTROL PANEL, AND WELDING GUN THAT FEEDS A CONSUMABLE ELECTRODE AT PRE-DETERMINED SPEED INTO A MOLTEN POOL UNDER A PROTECTIVE SHIELD OF ARGON GAS.
2. A WELDING POOL FORMS IMMEDIATELY WHEN THE ARC IS ESTABLISHED, AND WELDING PROGRESSES BY MOVING THE WELDING GUN ALONG THE JOINT LINE AT A RATE THAT WILDS UP A LAD OF DESIRED DIMENSIONS.
3. A SHIELD OF INERT GAS PROTECTS THE ELECTRODE AND WELD POOL FROM OXIDATION DURING WELDING. NO FLUX IS REQUIRED.

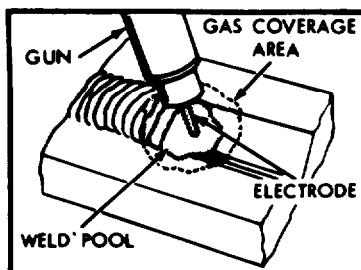

FILLET SIZE INCH	WIRE DIA. INCH	AMPS.	VOLTS	POL.	CURRENT	ARGON FLOW C.F.H.
1/8	3/64	140	21-24	REV.	D.C.	50
		175				
3/16	1/16	190	24-28	REV.	D.C.	50
		250				
1/4	1/16	190	24-28	REV.	D.C.	50
		250				
5/16	1/16	190	24-28	REV.	D.C.	50
		250				
3/8	3/32	350	28-31	REV.	D.C.	50
		390				

TA 014813 ■

Figure 2-4. MIG (metal-inert-gas) process of welding.

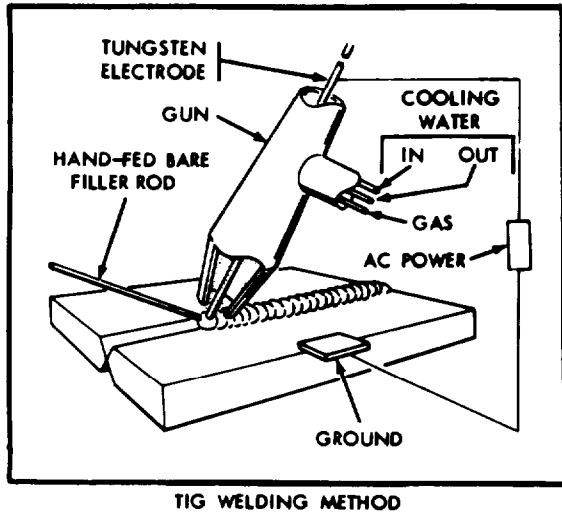

TIG (TUNGSTEN-INERT-GAS) PROCESS

1. THE "TIG" (TUNGSTEN-INERT-GAS) PROCESS UTILIZES AN AC POWER SOURCE CONTROL PANEL AND A WELDING GUN THAT HOLDS A NON-CONSUMABLE TUNGSTEN ELECTRODE.
2. A WELDING POOL FORMS IMMEDIATELY WHEN THE ARC IS ESTABLISHED, AND WELDING PROGRESSES BY MANUALLY FEEDING A BARE FILLER ROD TO THE MOLTEN POOL AND MOVING THE WELDING GUN AND FILLER ROD ALONG THE JOINT LINE AT A RATE THAT BUILDS UP A BEAD OF DESIRED DIMENSIONS.
3. A SHIELD OF INERT GAS - EITHER ARGON OR HELIUM, OR A MIXTURE OF BOTH - SURROUNDS THE ELECTRODE AND THE WELD POOL TO PREVENT OXIDATION DURING WELDING.
4. THE TIG PROCESS SHOULD NORMALLY BE USED ONLY WHEN WELDING TOGETHER SECTIONS OF 1/8 INCH THICKNESS OR LESS.

WELDING DATA FOR TIG WELDING METHOD							
THICKNESS INCH	TYPE OF WELD	WELDING CURRENT		WELDING ROD		TUNGSTEN ELECTRODE	ARGON FLOW C.F.H.
		TYPE	AMPERAGE	MATERIAL	SIZE INCH	SIZE INCH	
1/16	A-BUTT B-LAP C-TEE	ALTERNATING CURRENT HIGH-FREQUENCY STABILIZED	60-80	ALUM.	1/16	1/16	15
			70-90		1/16	1/16	15
			70-90		1/16	1/16	15
1/8	D-BUTT E-LAP F-TEE		125-145	ALUM.	3/32	3/32	17
			140-160		3/32	3/32	17
			140-160		3/32	3/32	17
3/16	G-BUTT H-LAP J-TEE		190-220	ALUM.	3/32	3/32	21
			210-240		3/32	3/32	21
			210-240		3/32	3/32	21
1/4	K-BUTT L-LAP M-TEE		260-300	ALUM.	1/8	1/8	21
		260-300	1/8		1/8	21	
		260-300	1/8		1/8	21	

TA 014814

Figure 2-5. TIG (tungsten-inert-gas) process of welding.



NOTE: DRILL NEW HOLE AT LEAST 1/2-INCH IN DIAMETER LARGER THAN HOLE TO BE REPAIRED. DIMENSIONS SHOWN ARE IN INCHES.

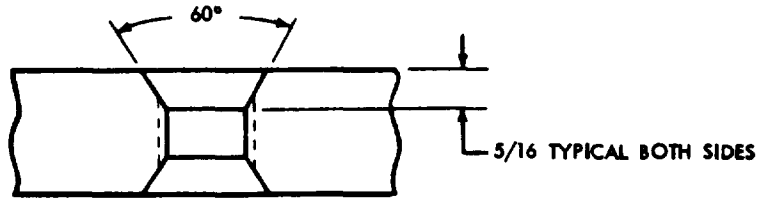

A. PREPARE THREADED HOLES THAT ARE DAMAGED OR OVERSIZE.

NOTE. COARSE THREADED PLUG TO MATCH DRILLED AND TAPPED HOLE ABOVE. DIMENSIONS SHOWN ARE IN INCHES.

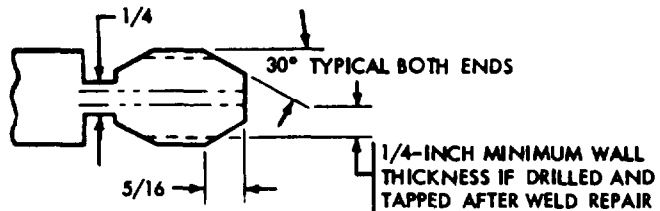

B. PREPARE THREADED PLUG TO MATCH THREAD OF HOLE BEING REPAIRED.

NOTE: DIMENSIONS SHOWN ARE IN INCHES.

NOTE. NUMBERS DENOTE WELDING PASSES.

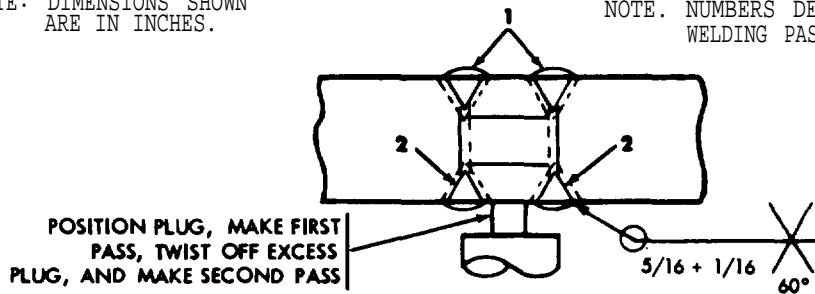

POSITION PLUG, MAKE FIRST PASS, TWIST OFF EXCESS PLUG, AND MAKE SECOND PASS

C. TYPICAL TWO-PASS WELD SEQUENCE USING 1/16-INCH ELECTRODE.

TA 014786

Figure 2-6. Welding using threaded plug.

**2-12. Specific Repair Data**

a. General

(1) Specific repair data (including inspection standards) are included with exploded views in chapter 3.

(2) Specific repair data (repair limits) give minimum inspection requirements and minimum, maximum, and principal clearances of new parts. Wear limits are listed which indicate the point to which parts may be worn before replacement.

(a) An asterisk (\*) in the "Repair limits" column indicates a part should be replaced when worn beyond the dimensions given in the "Size and fit of new parts" column.

(b) A double asterisk (\*\*) in "Repair limits" column indicates parts may be used if, by selective fitting, the clearance between two parts meets the required

clearance shown in the "Size and fit of new parts" column.

(c) The letter "L" following the fit of mating parts indicates a loose (clearance) fit. The letter "T" following the fit of mating parts indicates a tight (interference) fit.

Table 2-4. Components Covered by Specific Repair Data

Component	Figure
Fan clutch and shaft bearing retainer	3-38
Generator drive	3-67
Track hydraulic adjuster	3-83
Roadwheel arm	3-84
Track hydraulic adjuster idler arm	3-86
Track drive sprocket hub and axle shaft	3-87
Driver's hood and rotatable hatch	3-89
Bilge pump	3-106, 107, 108
Personnel heater	3-119 table 3-24

**Section IV. REMOVAL AND INSTALLATION OF MAJOR COMPONENTS**

**2-13. Scope**

Hull component removal and installation instructions contained in this chapter are listed in table 2-5.

Table 2-5. Hull Major Components

Component	Figure number
Driver's Hood and Rotatable Hatch	2-7
Fuel Tanks	2-8,2-9

**2-14. Detailed References**

a. Manuals containing removal and installation procedures for other major components of this vehicle are listed in table 2-6.

b. Technical manuals containing service instructions and repair parts for major components are listed in appendix.

Table 2-6. Vehicle Major Components

Component	Manual
Turret	TM 9-2350-230-35/2
152MM Gun/Launcher	TM 9-2350-230-35/2
Gun/Launcher Mount	TM 9-2350-230-35/2
Power Plant	TM 9-2350-230-20-1
Generator	TM 9-2350-230-20-1
Tracks and Suspension System	TM 9-2350-230-20-1

PRELIMINARY STFP

- A. ROTATE TURRET SO WEAPON POINTS OVER SIDE OF VEHICLE.  
 B. REFER TO TM 9-2350-230-20-1 AND REMOVE PERISCOPES FROM DRIVER'S HATCH COVER.

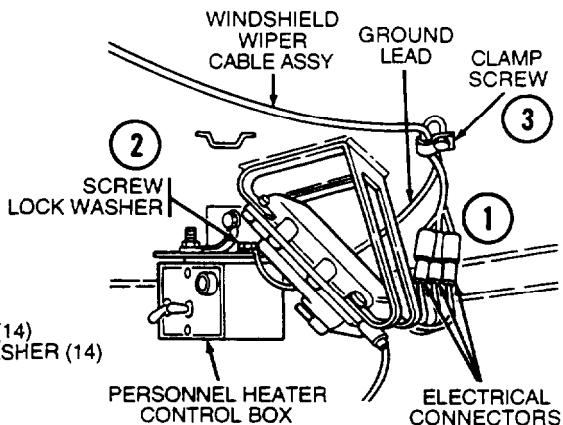
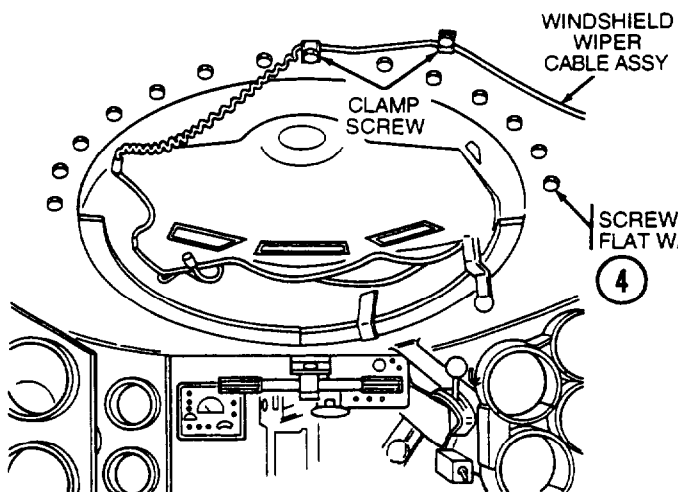

NOTE: DURING INSTALLATION, APPLY SEALING COMPOUND 8030-00-999-3895 BETWEEN HOOD AND HULL TOP PLATE.

REMOVAL

1. DISCONNECT WINDSHIELD WIPER CABLE AT 3 ELECTRICAL CONNECTORS NEAR DRIVER'S DOMELIGHT
2. REMOVE SCREW AND LOCK WASHER ATTACHING GROUND LEAD FROM CABLE ASSEMBLY TO PERSONNEL HEATER CONTROL BOX, DISCONNECT LEAD AND REINSTALL SCREW AND LOCK WASHER TO PREVENT LOSS.
3. REMOVE 3 SCREWS ATTACHING CABLE RETAINING CLAMPS TO HULL ROOF. REMOVE CABLE WITH CLAMPS, AND PLACE LOOSE CABLE OVER ATTACHED END TO PREVENT DAMAGE AT REMOVAL OF HATCH COVER. REINSTALL SCREWS TO PREVENT LOSS.

NOTE: IF REMOVAL OF CABLE IS NECESSARY, REFER TO FIGURE 3-59.

4. REMOVE 14 SCREWS AND FLAT WASHERS SECURING HATCH COVER TO HULL. MAKE SURE ROTATABLE HATCH IS CLOSED TO MAINTAIN BALANCE OF UNIT DURING LIFTING.

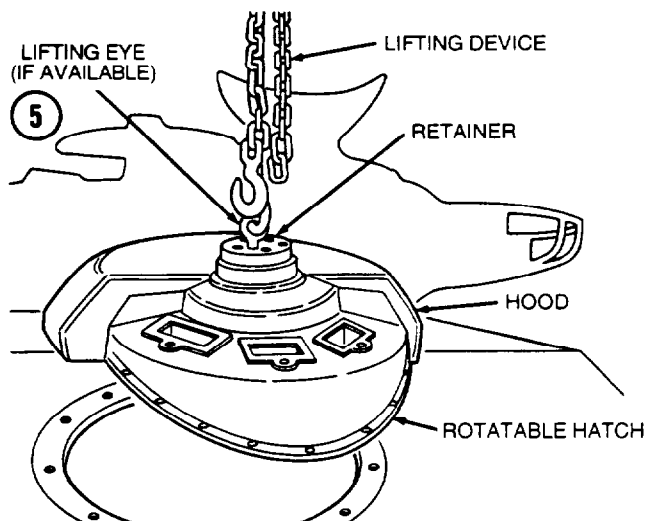

USED THROUGH VEHICLE NO. 69

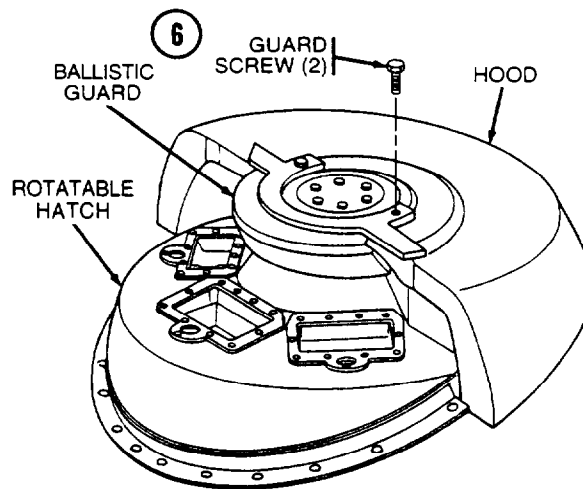

USED STARTING WITH VEHICLE NO. 70.

5. ON FIRST 69 VEHICLES, REMOVE ONE SCREW FROM HOOD RETAINER, INSERT EYEBOLT AND USE LIFTING DEVICE TO REMOVE HOOD AND ROTATABLE HATCH (WEIGHT - 449 LBS) FROM VEHICLE.
6. BEGINNING WITH VEHICLE NO. 70, REMOVE 2 SCREWS AND REMOVE BALLISTIC GUARD FROM HATCH HOOD. USE 2 EYEBOLTS (OR 2 LIFTING PLATES ATTACHED WITH GUARD SCREWS) AND USE 2-POINT LIFTING DEVICE OR SLING TO REMOVE HOOD AND ROTATABLE HATCH. ALSO REFER TO FIGURE 3-89.

TA014815

Figure 2-7. Removal of driver's hood and rotatable hatch.

NOTE. SIDE FUEL TANKS MAY BE REMOVED FROM VEHICLE WITHOUT REMOVING TURRET OR POWER PLANT. HOWEVER, POWER PLANT REMOVAL WILL ENABLE TANKS TO BE REMOVED MORE EASILY. THE FOLLOWING STEPS DESCRIBE REMOVAL OF FUEL TANKS WITHOUT REMOVING POWER PLANT.

LEFT FUEL TANK REMOVAL (REFER TO TM 9-2350-230-20.1 EXCEPT AS NOTED).

1. DRAIN FUEL TANKS (REFER TO TM 9-2350-230-10); REMOVE AIR-INTAKE GRILL; REMOVE TURRET 2 PROTECTIVE SCREENS AT LOADER'S POSITIONS; REMOVE BULKHEAD ENGINE ACCESS PLATES; REMOVE TURRET VERTICAL AMMUNITION HACK.
2. REMOVE DRIVER'S ROTATABL HATCH AN) HOOD (FIG.2-7).
3. REMOVE CAL .50 MACHINE GUN BRACKET, NIGHT VISION DEVICE AND CAL 7.62 AMMUNITION STOWAGE BRACKET; HULL LEFT AMMUNITION RACK REAR UPPER TIE-DOWN ARMS; AND HULL LEFT REAR AMMUNITION RACK.
4. SHUT OFF MAIN AIR VALVE AT CLOSED BREECH SCAVENGER SYSTEM AIR SUPPLY TANK, AND DISCONNECT AIR INLET AND OUTLET HOSES FROM AIR COMPRESSOR.
5. REMOVE AIR PURIFIER STEP PLATE AND ELEMENT; ODDMEMT BOX; AND LOADER'S SEAT.
6. REMOVE SCREWS AN) WASHERS AN) REMOVE CENTER BULKHEAD SEAL RETAINING BRACKETS AND SEALS.
7. REMOVE SCREWS FROM FLANGES AND REMOVE CENTER-TO-SIDE FUEL HOSE FROM SIDE TANK.
8. REMOVE SCREWS AND REMOVE FUEL FILLER AND FILTER FROM TANK.
9. REMOVE ELECTRICAL CONNECTOR AT LEFT FUEL TANK INDICATOR.
10. RELEASE 2 RETAINING STRAPS SECURING TANK TO SIDE OF HULL.
11. REMOVE SCREWS AND REMOVE BRACKET AT FRONT OF TANK.
12. POSITION GUN TUBE APPROXIMATELY 45° TO RIGHT OF FORWARD CENTER POSITION.
13. SLIDE TANK FORWARD APPROXIMATELY 18-INCHES AND THEN GUIDE TANK THROUGH DRIVER'S ROTATABL HATCH OPENING. TANK WEIGHS LESS THAN 100 POUNDS AND CAN BE HANDLED EASILY BY 2 MEN.

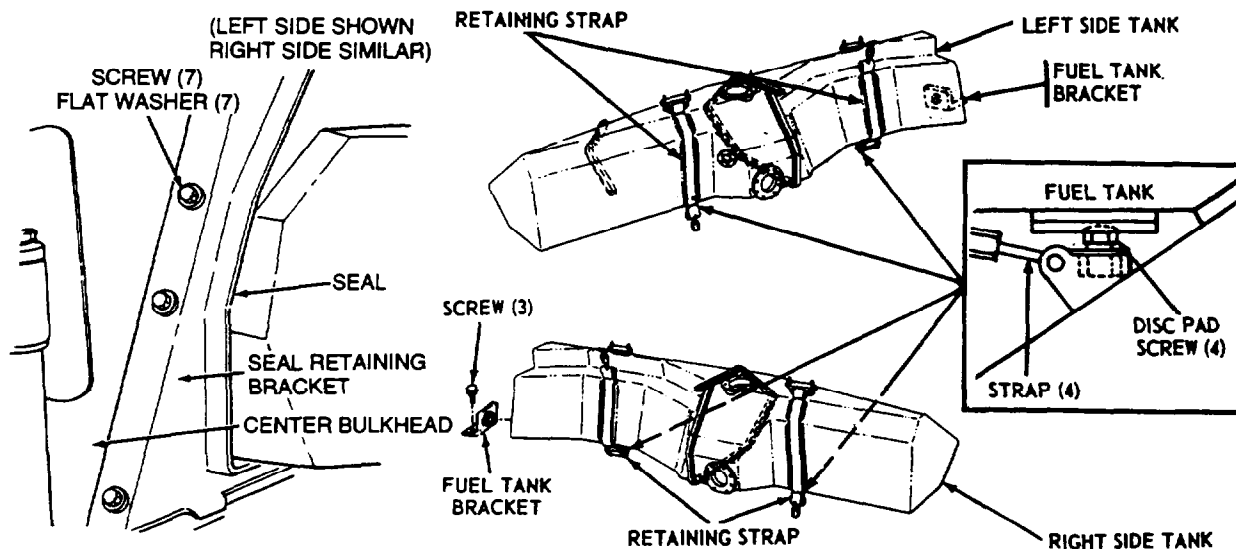

RIGHT FUEL TANK REMOVAL

NOTE. FOLLOW STEPS 1 THROUGH 11.

14. POSITION GUN TUBE APPROXIMATELY 165° TO RIGHT OF FORWARD CENTER POSITION.
15. SLIDE TANK FORWARD APPROXIMATELY 18-INCHES AND THEN GUIDE TANK THROUGH DRIVER'S ROTATABL HATCH OPENING.

INSTALLATION

1. SLIDE TANKS IN THROUGH DRIVER'S HATCH OPENING AND PLACE IN MOUNTING POSITION,
2. INSTALL CUSHIONING PADS AND RUBBER SEALS AS SHOWN IN FIGURE 3-10.
3. ENGAGE RETAINING STRAPS TO HOLD TANKS IN POSITION,
4. INSTALL TANK BRACKETS BUT DO NOT TIGHTEN SCREWS,
5. MAKE SURE REAR END OF TANKS ARE AGAINST TANK BULKHEAD,HOLD TANK BRACKETS AGAINST FRONT END OF TANKS AND TIGHTEN THREE SCREWS (FINGER TIGHT PLUS TWO TURNS) AND INSTALL LOCK WIRE,
7. ADJUST TANK DISC PAD SCREWS (UNDER EACH RETAINING STRAP) IF NECESSARY (FINGER TIGHT PLUS ONE TURN). INSTALL LOCK WIRE.
6. TIGHTEN STRAP TURNBUCKLES (FINGER TIGHT PLUS TWO TURNS) AND INSTALL LOCK WIRE.
8. REINSTALL COMPONENTS REMOVED IN STEPS 9 THROUGH 1.

*Figure 2-8. Removal/installation of side fuel tanks.*

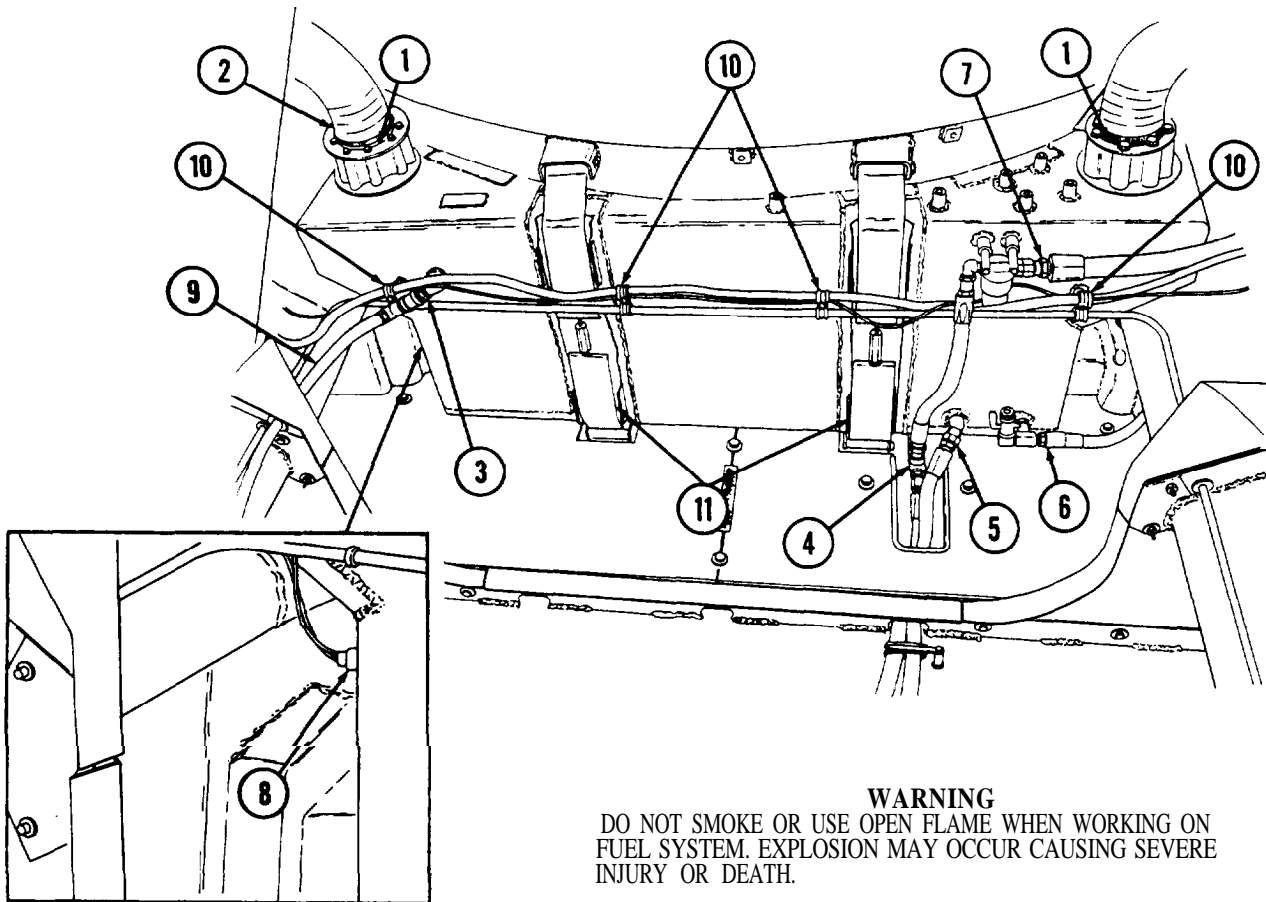
**WARNING**

DO NOT SMOKE OR USE OPEN FLAME WHEN WORKING ON FUEL SYSTEM. EXPLOSION MAY OCCUR CAUSING SEVERE INJURY OR DEATH.

PRELIMINARY STEP

REMOVE POWER PLANT (TM 9-2350-230-20-1) AND DRAIN FUEL TANKS (TM 9-2350-230-10).

NOTE. IF WINTERIZATION KIT IS INSTALLED COMPONENTS MUST BE REMOVED FROM FUEL TANK BEFORE REMOVING TANK.

REMOVAL

1. CUT LOCK WIRE, REMOVE 16 SCREWS AND FLAT WASHERS AND DISCONNECT SIDE TANKS-TO-CENTER TANK ELBOWS AT VALVE BODIES.
2. REMOVE 2 COTTER PINS AND FLAT WASHERS TO DISCONNECT VALVE CONTROL LINKS AT VALVE CONTROL ARMS.
3. DISCONNECT FUEL RETURN HOSE AT CHECK VALVE ELBOW.
4. DISCONNECT FUEL DRAIN HOSE AT TEE.
5. DISCONNECT FUEL SUPPLY HOSE AT ELBOW IN FUEL TANK.
6. DISCONNECT PERSONNEL HEATER FUEL SUPPLY HOSE AT TEE IN FUEL TANK.
7. DISCONNECT HAND DRIVEN PUMP HOSE AT FILTER ON FUEL TANK.
8. DISCONNECT ELECTRICAL LEAD CONNECTORS AT CENTER FUEL TANK INDICATOR.
9. DISCONNECT FIRE EXTINGUISHER CROSSOVER TUBE AT LEFT AND RIGHT DISCHARGE TUBES.
10. REMOVE 4 SCREWS, 4 CLAMPS, AND 4 FLAT WASHERS FROM BACK OF CENTER FUEL TANK AND REMOVE FIRE EXTINGUISHER CROSSOVER TUBE.
11. RELEASE 2 FUEL TANK RETAINING STRAPS AND REMOVE TANK FROM VEHICLE.
12. REMOVE FUEL FILTER, LINES, AND FITTINGS FROM TANK.

INSTALLATION

INSTALL FUEL FILTER, LINES, AND FITTINGS ON TANK; THEN REINSTALL TANK IN REVERSE ORDER OF REMOVAL. INSURING THAT ALL CUSHIONING PADS AND RUBBER SEALS ARE INSTALLED.

Figure 2-9. Removal/installation - center fuel tank.

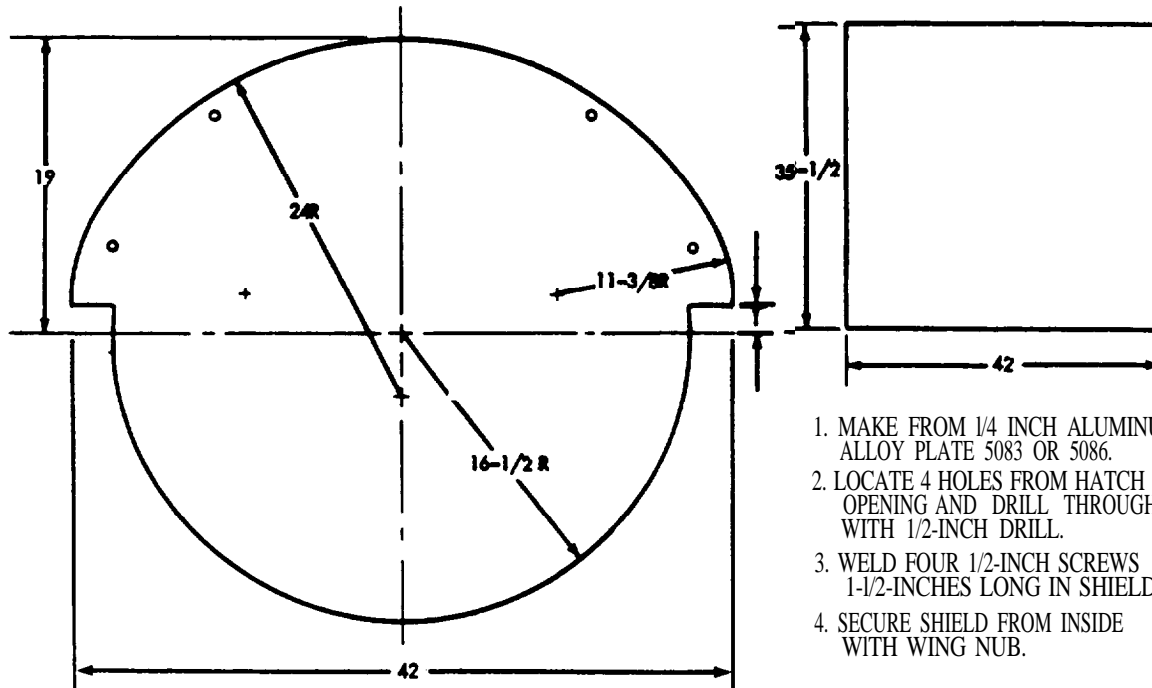

A. DRIVER'S HATCH OPENING SECURITY SHIELD.

1. MAKE FROM 1/4 INCH ALUMINUM ALLOY PLATE 5083 OR 5086.
2. LOCATE 4 HOLES FROM HATCH OPENING AND DRILL THROUGH WITH 1/2-INCH DRILL.
3. WELD FOUR 1/2-INCH SCREWS 1-1/2-INCHES LONG IN SHIELD.
4. SECURE SHIELD FROM INSIDE WITH WING NUB.

NOTE. SHIELD IS USED AFTER HOOD AND ROTATABLE HATCH IS REMOVED (FIG. 2-7).

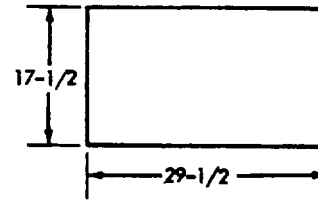
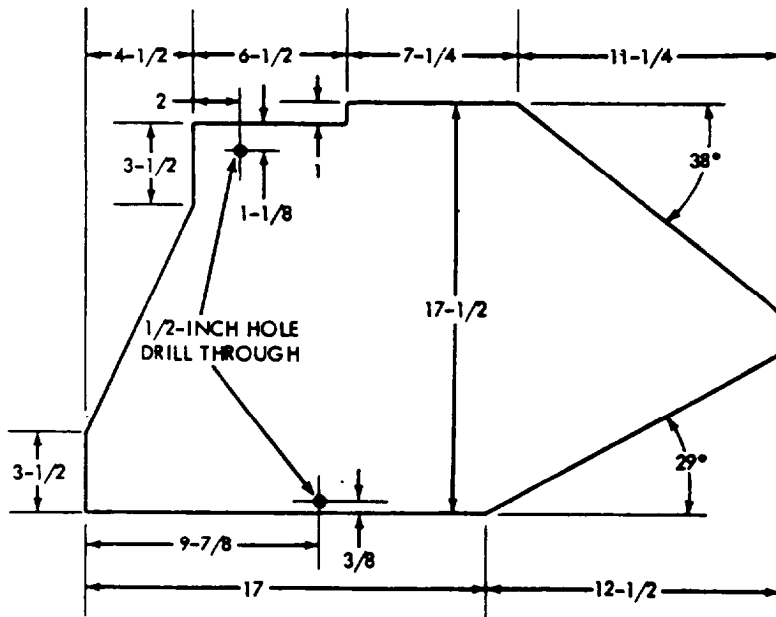

B. ENGINE COMPARTMENT BULKHEAD RIGHT AND LEFT OPENINGS SECURITY SHIELD.

1. MAKE FROM 1/8 INCH ALUMINUM PLATE 5083 OR 5086 (2 REQUIRED).
2. RETAIN IN POSITION USING SEAL AND BRACKET SCREWS AND WASHERS (FIG. 2-8).

NOTE. SHIELDS ARE USED AFTER SIDE FUEL TANKS ARE REMOVED (FIG. 2-8).

TA 014816

Figure 2-10. Fabrication of driver's hatch and bulkhead opening security shields.

## CHAPTER 3

### REPAIR OF COMPONENTS AND ASSEMBLIES FOR M551/M551A1

#### Section I. GENERAL

##### 3-1. Scope

This chapter contains information for the guidance of direct and general support maintenance personnel, as authorized by the MAC, for performing general maintenance, repair, and installation of the major components of the M551/M551A1. Generally, the prescribed maintenance responsibilities or practicability of maintenance functions must be determined by the availability of repair parts, either supplied through normal channels or salvaged from another vehicle of the same kind.

##### 3-2. Techniques

“Inspect and repair only as necessary,” is the maintenance

technique whereby end items, components or assemblies are restored to prescribed serviceability standards after determining the need for performing the minimum essential maintenance required. It implements the principles of economical maintenance operations by requiring thorough diagnosis of major items and components before repair or replacement. This technique does not cancel essential disassembly or teardown to assure the proper serviceability standards for the components and/or major item involved. It does not change or lower the required quality of maintenance or prescribed serviceability standards.

#### Section II. REPAIR OF POWER PLANT

##### 3-3. Scope

*a.* Procedures for separating/assembling engine and transmission are illustrated and described in figure 3-1.

*b.* Instructions for fabricating a portable power plant test stand are contained in figure 1-3.

##### 3-4. Detailed References

*a.* Removal and installation of power plant (TM 9-2350-230-20-1).

*b.* Cleaning instructions (para 2-1).

*c.* Preservation, packaging and packing of military supplies and equipment packing (TM 38-230-1 and TM 38-230-2.)

*d.* Engine overhaul (DMWR 9-2815-205).

*e.* Transmission overhaul (DMWR 9-2520-249).

##### 3-5. Operational Test

*a.* Test operations cannot be conducted on repaired power plants until the following materiel is acquired and attached:

(1) Cooling system - radiator, fan, hoses, etc.

(2) Engine coolant temperature switch and transmitter.

(3) Engine oil pressure switch and transmitter.

(4) Transmission oil cooler and transmission-to-oil cooler hoses and elbows.

(5) Source of electrical power for starting (24-volt).

(6) Starter relay.

(7) Engine electrical harness.

(8) Source and connections for fuel supply.

(9) Tachometer.

(10) Transmission temperature and oil pressure switches.

(11) Indicator panel - gages for coolant and oil pressure switches and transmitter.

*b.* Refer to LO 9-2350-230-12 for proper grade and quantity of oil required in engine and transmission.

*c.* Refer to figure 3-3 and figure 3-4 for illustration of complete power plant.

##### 3-6. Stall Test

Refer to figure 3-5.

##### 3-7. Engine Crankshaft Pulley

Refer to figure 3-6.

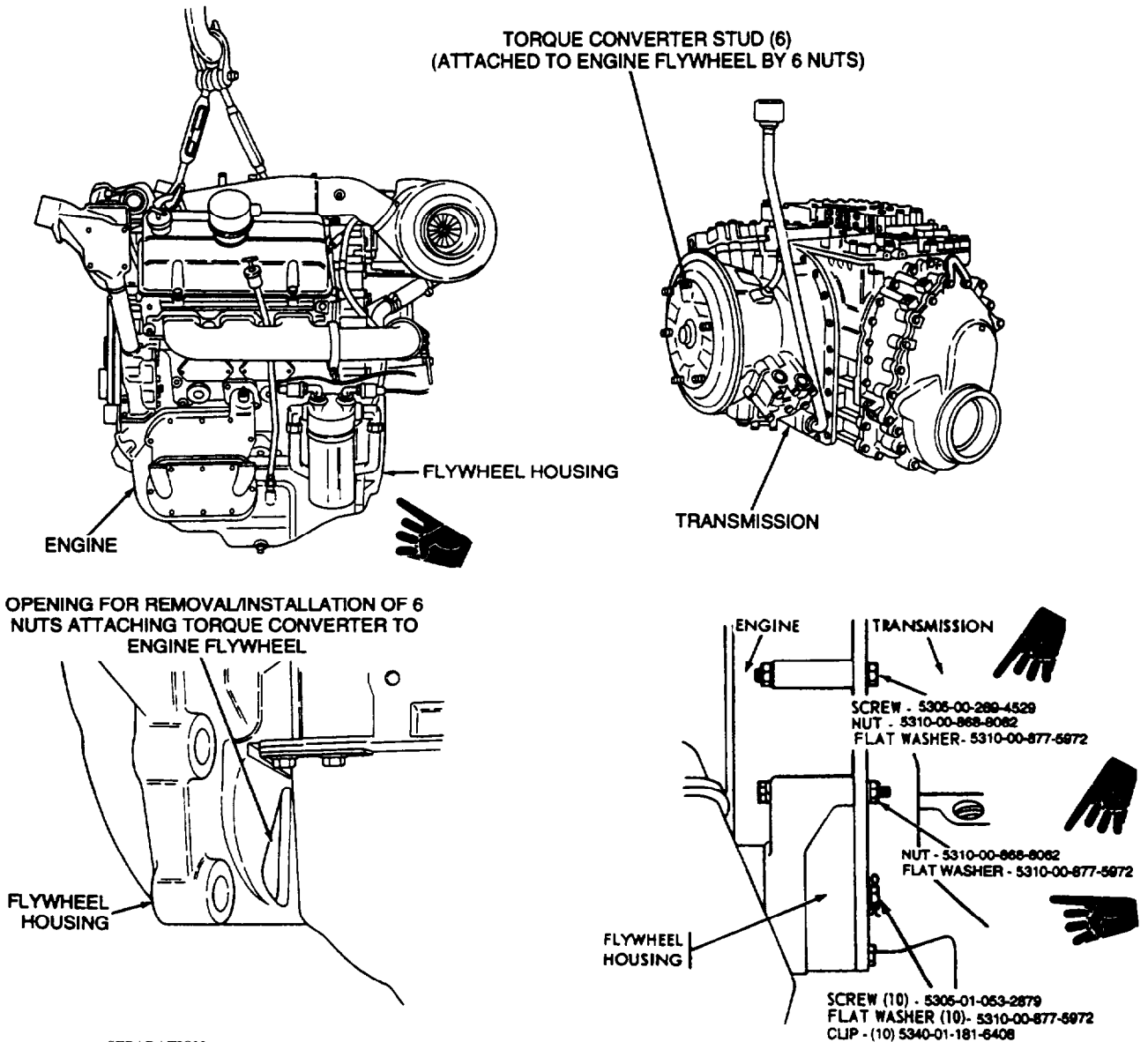

**SEPARATION**

1. PLACE ASSEMBLED POWER PLANT ON IMPROVISED STAND (FIG. 1-3) IF STAND IS NOT AVAILABLE. USE BLOCKS UNDER TRANSMISSION AND ENGINE AND OBTAIN HOIST AND LIFTING SLING.
2. USE 9/16-INCH SOCKET WITH RATCHET OR BREAKER BAR INSERTED AT OPENING IN ENGINE FLYWHEEL HOUSING, AND REMOVE 6 NUTS (AND DISCARD) WHICH ATTACH TRANSMISSION TORQUE CONVERTER STUDS TO ENGINE FLYWHEEL. ROTATE FLYWHEEL TO GAIN ACCESS TO EACH NUT. IF FLYWHEEL WILL NOT ROTATE, INTERNAL DAMAGE IS INDICATED AND MUST BE CORRECTED BEFORE DISASSEMBLY (SEE PARAGRAPH 4-1. TM 9-2815-205-34).
3. REMOVE AND DISCARD THE 2 NUTS, 11 SCREWS, 10 CUPS, AND 13 FLAT WASHERS ATTACHING TRANSMISSION TO ENGINE FLYWHEEL HOUSING AND MOVE ENGINE AWAY FROM TRANSMISSION UNTIL STUDS ARE CLEAR OF FLYWHEEL WHEN SEPARATING THE ENGINE AND TRANSMISSION, AVOID DAMAGING MATING SURFACES.

**NOTE**

BEFORE ASSEMBLY, INSURE THAT THE CORRECT HEIGHT OF STACK CONTROL SPACERS ARE ON EACH OF THE 6 TORQUE CONVERTER PUMP COVER STUDS (SEE VIEW A, FIG. 3-2). IF ANY OF THE SPACERS ARE MISSING, NOTIFY GENERAL SUPPORT MAINTENANCE.

**ASSEMBLY**

4. ALIGN ENGINE FLYWHEEL WITH TRANSMISSION TORQUE CONVERTER STUDS AND JOIN ENGINE AND TRANSMISSION.

**NOTE**

IF BELL-HOUSING PREVENTS ANY OF 10 CUPS 5340-01-181-6408 FROM SEATING PROPERLY, CAREFULLY TURN AFFECTED SCREW COUNTER-CLOCKWISE UNTIL CUP SEATS PROPERLY. DO NOT TURN SCREW MORE THAN 30° (HALF THE ANGLE BETWEEN TWO SCREW HEAD HOLES).

5. INSTALL 1 SCREW (NEW), 10 SCREWS 5305-01-053-2879 (NEW), 10 CUPS 5340-01-181-6408, 13 FLAT WASHERS (NEW), AND 2 SELF-LOCKING NUTS 5310-00-868-8062 (NEW) (IDENTIFIED BY 6 RAISED DOTS ON CONICAL HEAD) ATTACHING TRANSMISSION TO ENGINE FLYWHEEL HOUSING. TIGHTEN SCREWS 5305-01-053-2879 TO 38 LB-FT. TIGHTEN SCREWS 5303-00-269-4529 AND NUTS 5310-00-868-8062 TO 27-32 LB-FT.
6. INSTALL 6 NUTS (NEW) ON TRANSMISSION TORQUE CONVERTER STUDS, ROTATING ENGINE FLYWHEEL TO GAIN ACCESS TO EACH STUD. TIGHTEN NUTS TO 30-36 LB-FT.

**Figure 3-1. Separation/assembly — engine and transmission.**



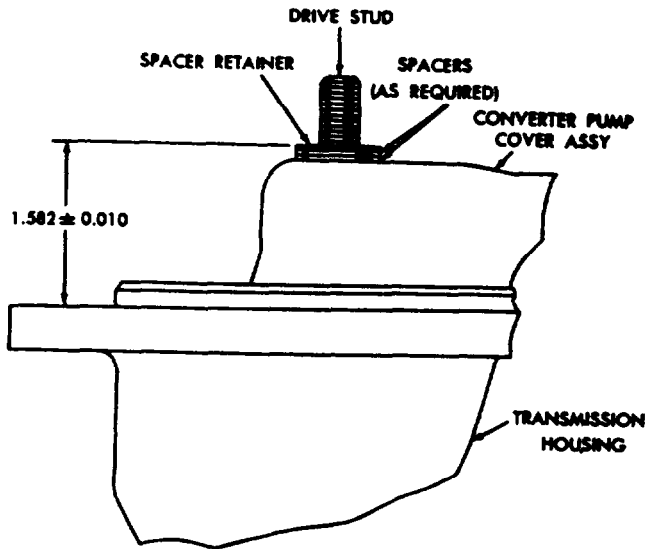

(Kit, spacer NSN 2520-00-045-3216)  
 Stack control spacers are available in thicknesses and color codes as follows:

Thickness	Color Code
0.027 - 0.029	Gold
0.045 - 0.047	Silver
0.063 - 0.065	Copper
0.081 - 0.083	Black
0.099 - 0.101	Plain

VIEW A

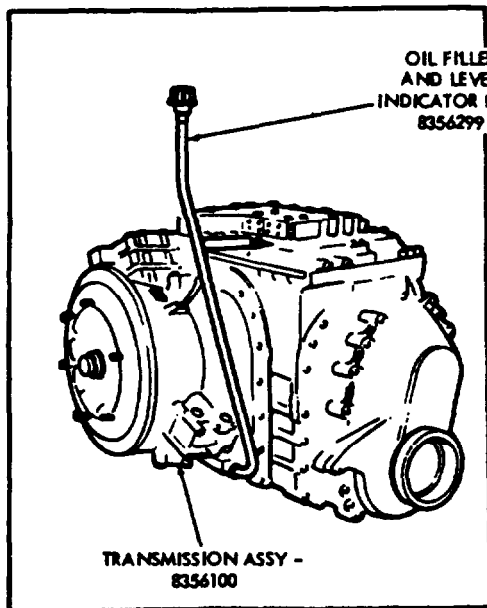

XTG-250-1A TRANSMISSION  
 8356300

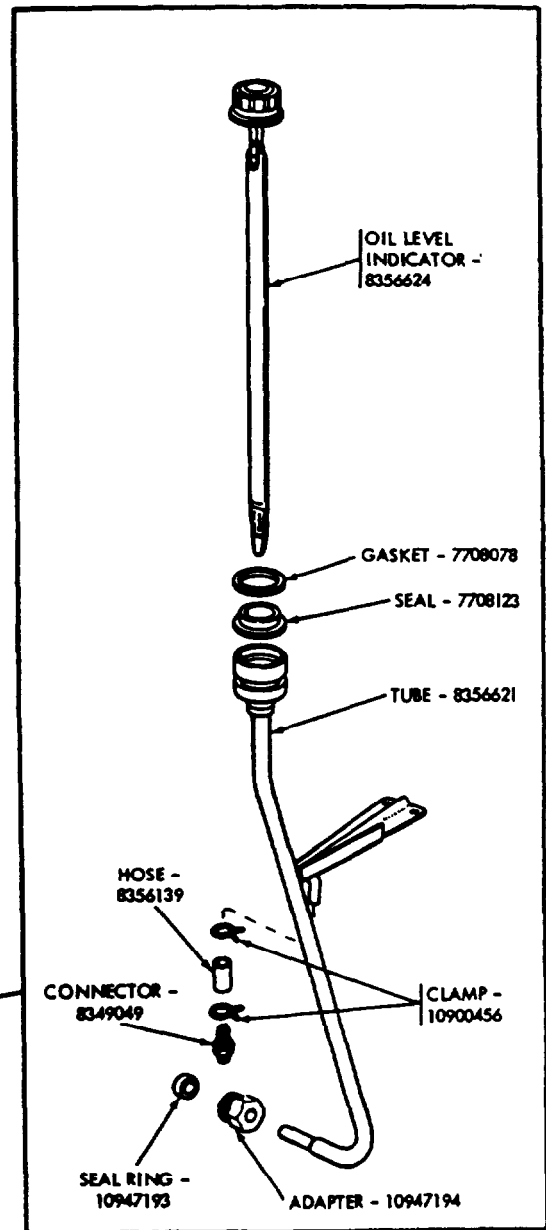

NOTE. WHEN REPLACING TRANSMISSION, IT WILL BE NECESSARY TO REMOVE ALL COMPONENTS OF OIL FILLER AND LEVEL INDICATOR KIT FROM OLD TRANSMISSION FOR INSTALLATION ON REPLACEMENT TRANSMISSION OR NEW PARTS ORDERED. USE EXISTING SCREWS ON TRANSMISSION TO INSTALL KIT.

TA 014790

Figure 3-2. XTG-250-1A transmission assembly.

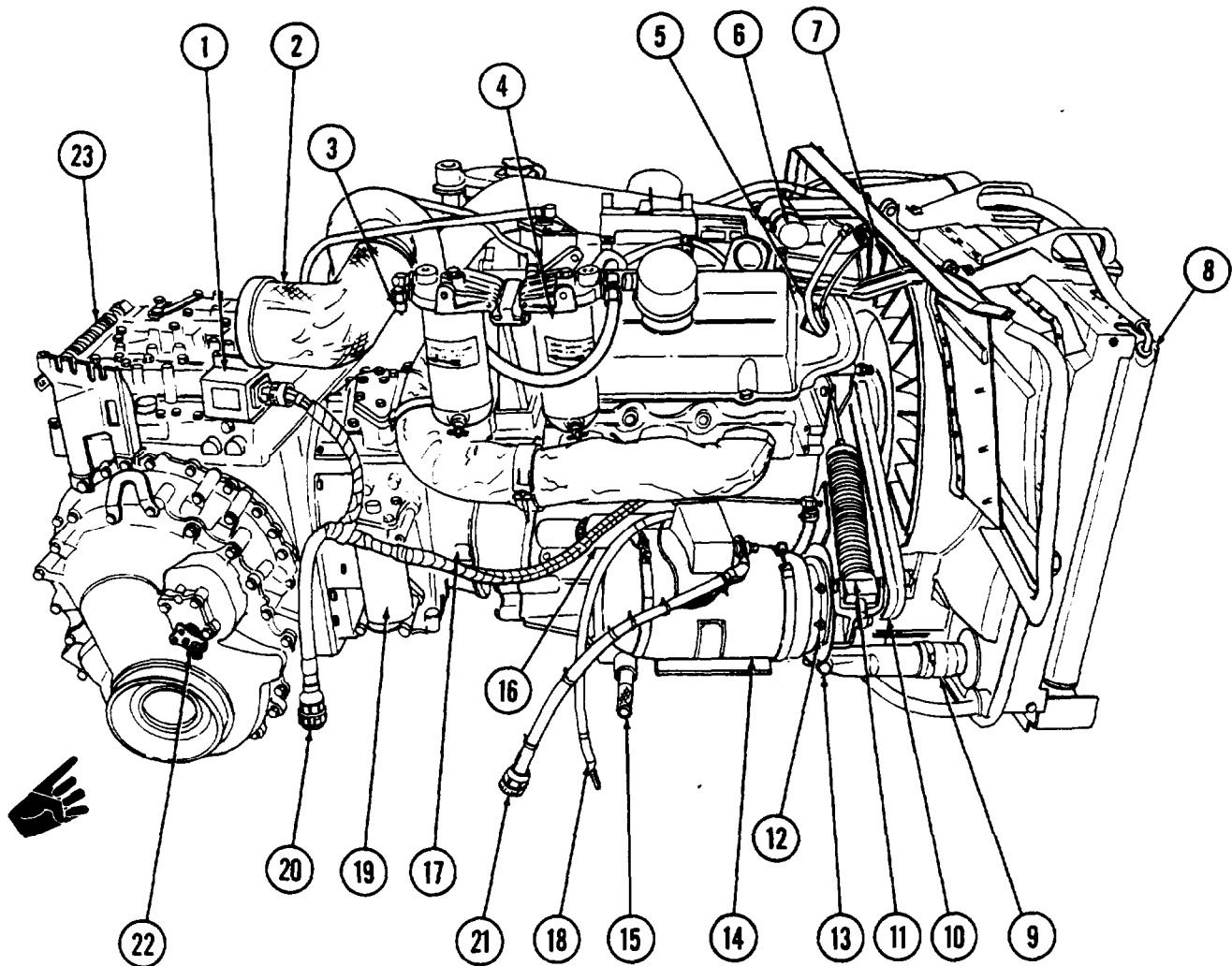

- |                                       |  |
|---------------------------------------|--|
| 1. STARTER RELAY BOX                  | 13. COOLANT DRAIN PLUG                     |
| 2. ENGINE EXHAUST ELBOW               | 14. GENERATOR                              |
| 3. MAIN FUEL HOSE QUICK DISCONNECT    | 15. ENGINE MOUNT SCREW                     |
| 4. PRIMARY FUEL FILTER                | 16. ENGINE STARTER                         |
| 5. CRANKCASE BREATHER HOSE            | 17. MOUNTING SCREW                         |
| 6. AIR PUMP                           | 18. POWER PLANT GROUND CABLE               |
| 7. ENGINE COOLING FAN                 | 19. TRANSMISSION OIL FILTER                |
| 8. RADIATOR                           | 20. GENERATOR-TO-VOLTAGE REGULATOR HARNESS |
| 9. RADIATOR OUTLET TUBE ASSEMBLY      | 21. STARTER-TO-BATTERY CABLE               |
| 10. GENERATOR/COOLING FAN DRIVE BELTS | 22. SPEEDOMETER ADAPTER                    |
| 11. BELT TENSIONER                    | 23. BRAKE CABLE                            |
| 12. GENERAL DRIVE ASSEMBLY            |  |

Figure 3-3. Power plant - right side - reference.

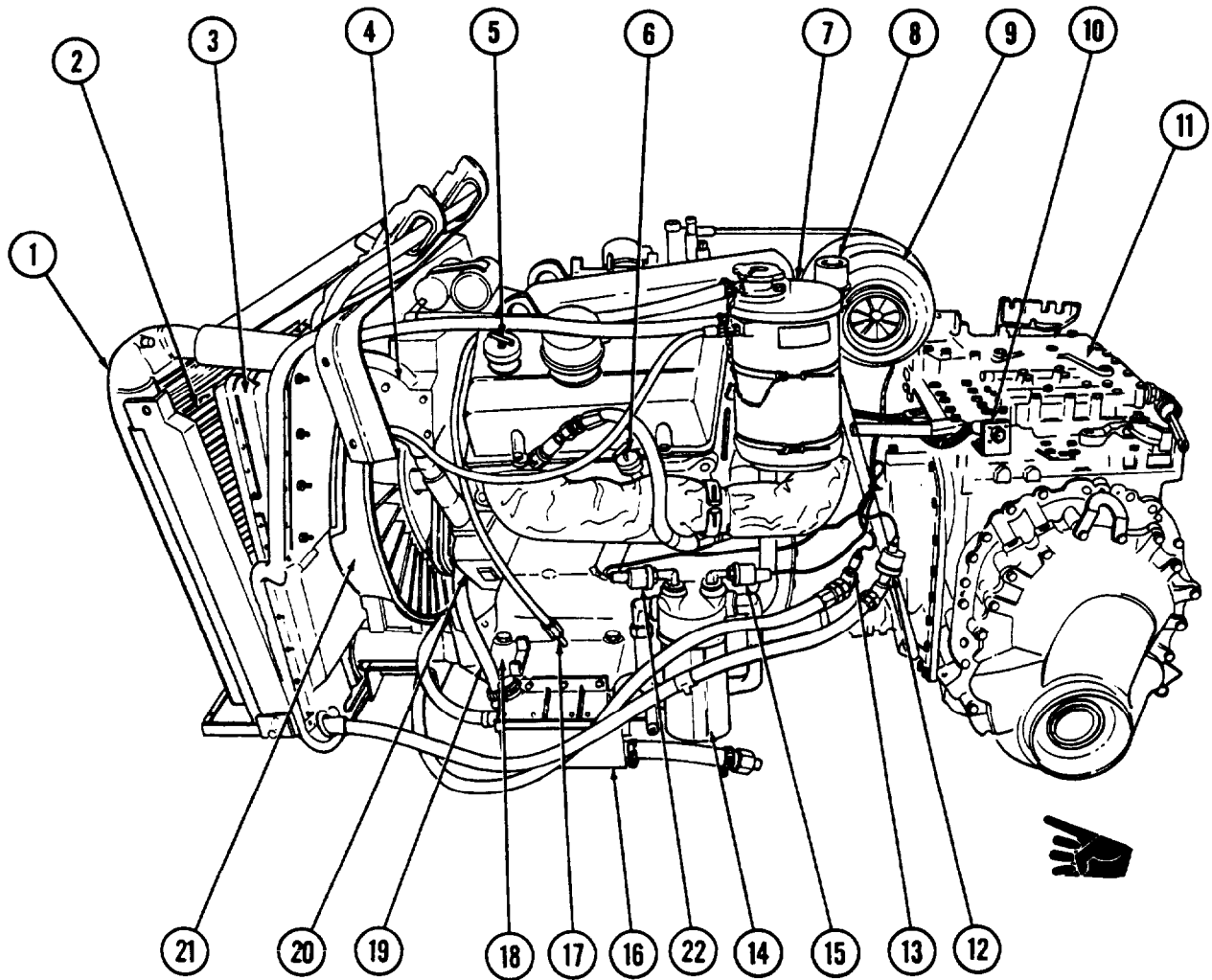

- |                                   |   |
|-----------------------------------|---|
| 1. RADIATOR                       | 12. TRANSMISSION OIL PRESSURE SWITCH    |
| 2. TRANSMISSION OIL COOLER        | 13. TRANSMISSION OIL TEMPERATURE SWITCH |
| 3. ENGINE COOLING FAN SHROUD      | 14. ENGINE OIL FILTER                   |
| 4. THERMOSTAT HOUSING             | 15. ENGINE OIL LOW PRESSURE SWITCH      |
| 5. ENGINE OIL FILLER CAP          | 16. ENGINE BREATHER DRAIN COLLECTOR BOX |
| 6. ENGINE OIL LEVEL GAGE          | 17. ENGINE FUEL RETURN HOSE             |
| 7. COOLANT SURGE TANK             | 18. ENGINE OIL COOLER                   |
| 8. TRANSMISSION OIL LEVEL GAGE    | 19. AIR BOX DRAIN HOSE                  |
| 9. TURBOCHARGER                   | 20. ENGINE COOLANT PUMP                 |
| 10. ELECTRICAL HARNESS RECEPTACLE | 21. ENGINE COOLING FAN                  |
| 11. TRANSMISSION                  | 22. BLOWER MOTOR RELAY SWITCH           |

Figure 3-4. Power plant - left side -reference.

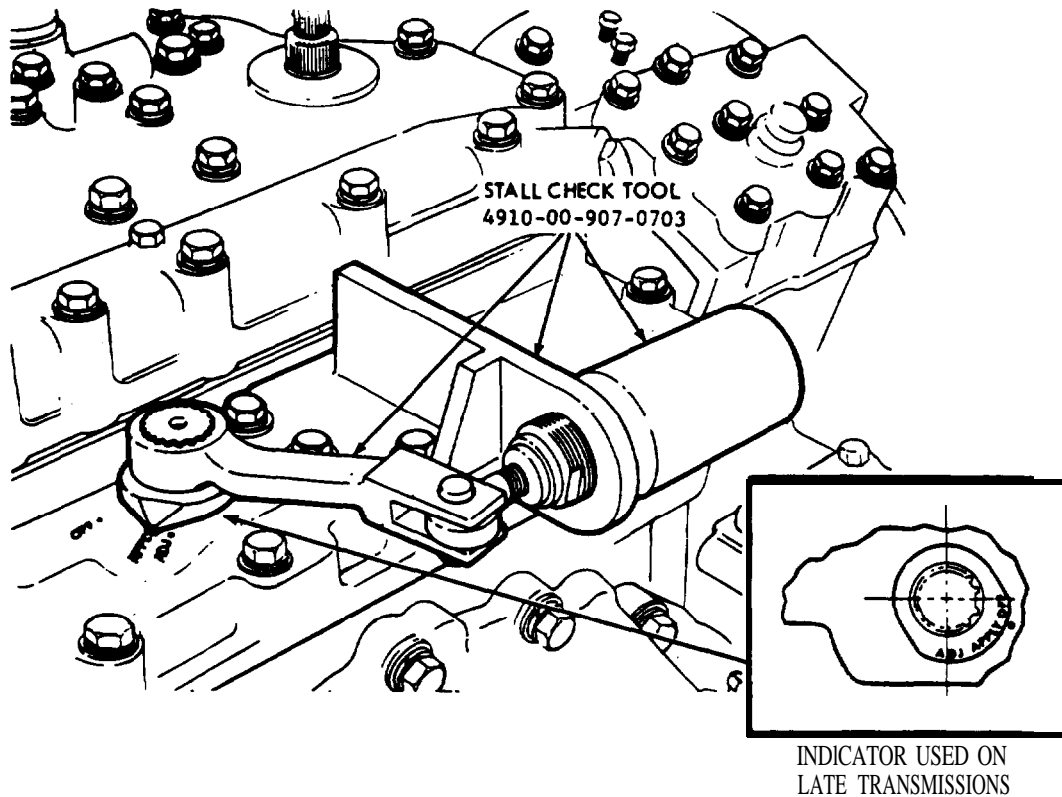

INSTALLATION

1. REMOVE SNAP RING AND BRAKE APPLY LEVER FROM RIGHT SIDE OF TRANSMISSION.
2. REMOVE TRANSMISSION INSPECTION COVER.
3. INSTALL STALL CHECK TOOL - 4910-00-907-0703. USE EXISTING SCREWS AND WASHERS,

STALL TEST PROCEDURE

1. CHECK ENGINE COOLANT AND OIL LEVELS AND TRANSMISSION OIL LEVEL. ADD IF REQUIRED.
  2. PLACE SHIFT CONTROL IN NEUTRAL POSITION AND WATER STEER CONTROL IN LAND POSITION.
  3. OPERATE ENGINE AT 1500 RPM (FAST IDLE) UNTIL ENGINE HAS WARMED TO OPERATING TEMPERATURE (160° TO 185° F.).
  4. STOP ENGINE AND TIGHTEN TOOL ADJUSTER UNTIL BRAKE IS APPLIED (INDICATOR ON BRAKE SHAFT WILL BE AT OR BEYOND "APPLY" POSITION).
  5. ENGAGE MANUAL LOCKUP ON COOLING FAN DRIVE CLUTCH (FIG. 3-22) SO THAT FAN IS MECHANICALLY DRIVEN THROUGHOUT TEST.
  6. START ENGINE, PULL TRANSMISSION SHIFT LEVER IN 4TH RANGE, AND APPLY FULLTHROTTLE. DO NOT HOLD ENGINE AT FULL THROTTLE LONGER THAN NECESSARY TO READ STALL RPM'S. 5 SECONDS SHOULD BE ENOUGH. ENGINE SPEED SHOULD REACH BETWEEN 2,100 TO 2,400 RPM.
- CAUTION: OPERATING POWER PLANT OVER 30 SECONDS IN "STALL" MAY CAUSE TRANSMISSION OIL TO OVERHEAT. IF TRANSMISSION OIL TEMPERATURE WARNING LIGHT COMES ON (INDICATING HIGH OIL TEMPERATURE), SHIFT TRANSMISSION TO NEUTRAL AND IDLE ENGINE AT 1200 - 1500) RPM FOR 3 TO 5 MINUTES.
7. IF ENGINE STALL SPEED IS SUBSTANTIALLY, BELOW 2,100 RPM, ENGINE IS NOT DELIVERING FULL POWER. REFER TO TM 9-2815-205-34.
  8. IF ENGINE STALL SPEED IS SUBSTANTIALLY ABOVE 2,400 RPM, CLUTCH SLIPPAGE IS PRESENT IN TRANSMISSION. REFER TO TM 9-2520-249-34.
  9. REMOVE STALL CHECK TOOL AND REPLACE TRANSMISSION COVER, BRAKE APPLY LEVER, AND SNAP RING.
  10. RELEASE MANUAL LOCKUP ON COOLING FAN DRIVE CLUTCH (FIG. 3-22) TO RETURN FAN DRIVE TO NORMAL OPERATING CONDITION.

TA 014817

*Figure 3-5. Stall test of power plant using stall check tool — 4910-00-907-0703.*

NOTE. WHEN INSTALLING PULLEY, DO NOT USE BOLT AND RETAINER(WASHER) SUPPLIED WITH REPLACEMENT ENGINES. THESE ARE FOR SHIPPING ONLY, USE SCREW-8743903-7 AND WASHER-11594035.

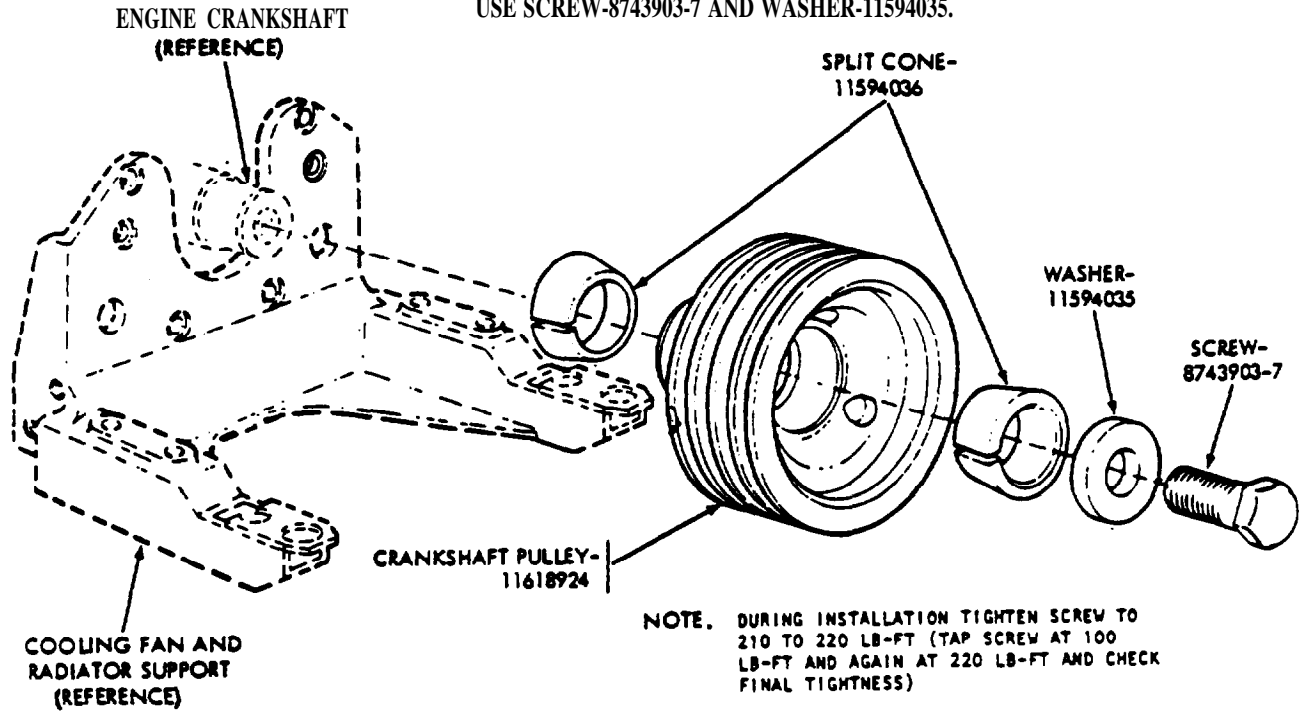
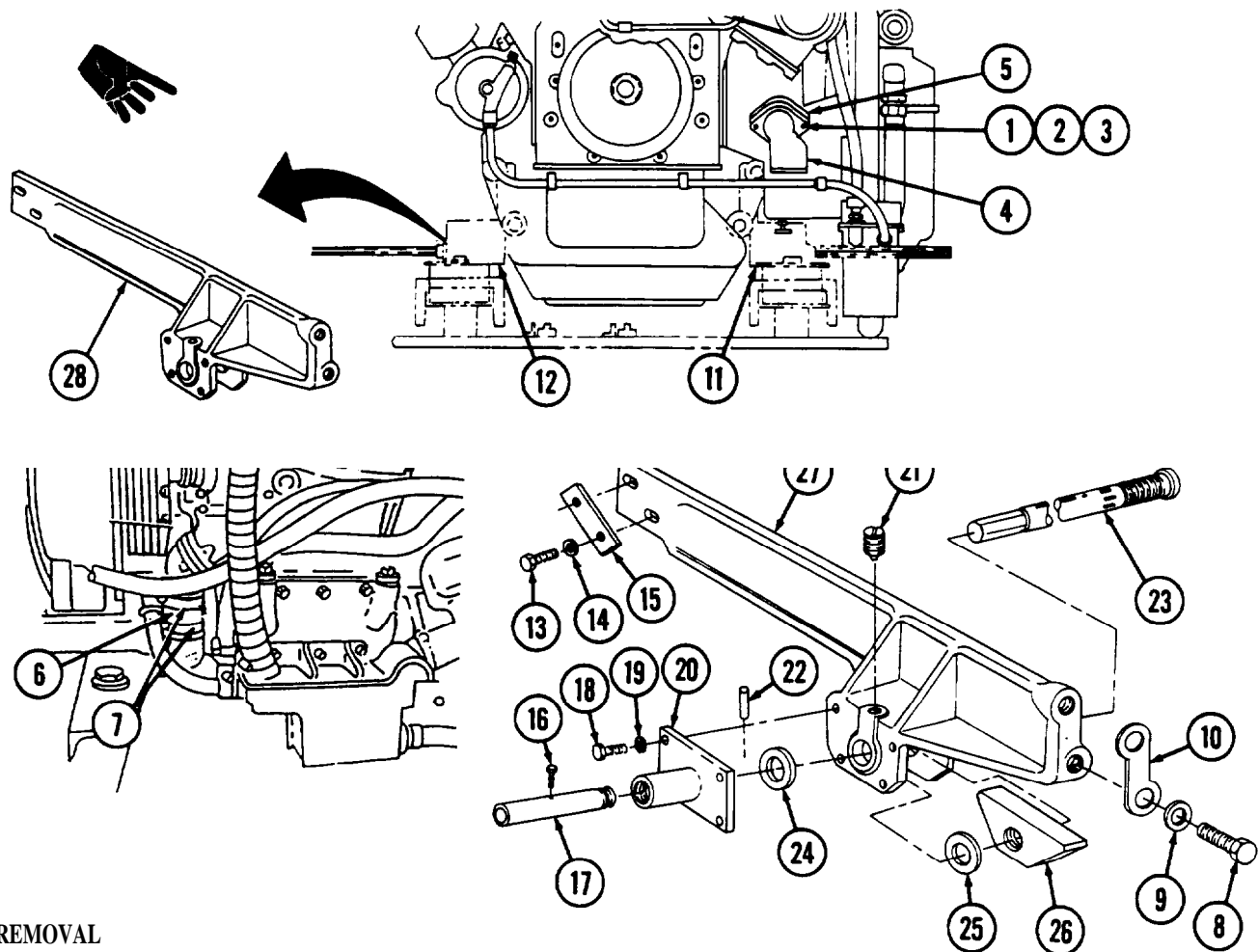

Figure 3-6. Engine crankshaft pulley.

### 3-7.1. Engine Mounts

Refer to figure 3-6.1.



**REMOVAL**

1. REMOVE POWER PLANT.
2. DRAIN ENGINE COOLANT SYSTEM.
3. REMOVE TWO SCREWS (1), TWO LOCKWASHERS (2), TWO FLAT WASHERS (3), OIL COOLANT INLET ELBOW (4), GASKET (5), HOSE (6), AND TWO HOSE CLAMPS (7).
4. REMOVE FOUR SCREWS (8), FOUR FLAT WASHERS (9), AND TWO LOCKING PLATES (10) FROM REAR OF LEFT AND RIGHT ENGINE MOUNT GROUPS (11 AND 12).
5. REMOVE FOUR SCREWS (13), FOUR FLAT WASHERS (14), TWO LOCKING PLATES (15), AND LEFT AND RIGHT ENGINE MOUNT GROUPS (11 AND 12).
6. REMOVE TWO STRAIGHT PINS (16) AND TWO TUBES (17).
7. REMOVE EIGHT SCREWS (18), EIGHT LOCKWASHERS (19), AND TWO BRACKETS (20).
8. REMOVE TWO QUICK RELEASE PLUNGERS (21).
9. REMOVE TWO SPRING PINS (22), TWO MOUNT SCREWS (23), FOUR FLAT WASHERS (24 AND 25), AND TWO SELF-LOCKING NUTS (26) FROM LEFT AND RIGHT ENGINE MOUNTS (27 AND 28).

**INSTALLATION**

1. INSTALL TWO NEW SELF-LOCKING NUTS (26), FOUR FLAT WASHERS (24 AND 25), AND TWO MOUNT SCREWS (23) TO LEFT AND RIGHT ENGINE MOUNTS (27 AND 28). TORQUE MOUNT SCREWS (23) TO 175 LB-FT. INSTALL TWO NEW SPRING PINS (22).
2. APPLY SEALING COMPOUND MIL-S-22473, GRADE E, TO TWO QUICK RELEASE PLUNGERS (21) AND INSTALL.
3. INSTALL TWO BRACKETS (20), EIGHT NEW LOCKWASHERS (19), AND EIGHT SCREWS (18).
4. INSTALL TWO TUBES (17) AND TWO STRAIGHT PINS (16).
5. INSTALL LEFT AND RIGHT ENGINE MOUNT GROUPS (11 AND 12), TWO NEW LOCKING PLATES (15), FOUR FLAT WASHERS (14), AND FOUR SCREWS (13). TORQUE SCREWS (13) TO 110 LB-FT AND FOLD NEW LOCKING PLATES (15) AGAINST TORQUED SCREWS.
6. INSTALL TWO LOCKING PLATES (10), FOUR FLAT WASHERS (9), AND FOUR SCREWS (8) TO REAR OF LEFT AND RIGHT ENGINE MOUNT GROUPS (11 AND 12). TORQUE SCREWS (8) TO 275 LB-FT AND FOLD NEW LOCKING PLATES (10) AGAINST TORQUED SCREWS.
7. INSTALL TWO HOSE CLAMPS (7), HOSE (6), NEW GASKET (5), OIL COOLANT INLET ELBOW (4), TWO FLAT WASHERS (3), TWO NEW LOCKWASHERS (2), AND TWO SCREWS (1).
8. FILL ENGINE COOLANT SYSTEM.

Figure 3-6.1. Engine mounts.

### 3-8. Replacement of Transmission Trunnion Cap

Procedure for replacement of the transmission trunnion cap is described below and illustrated in figures 3-7 through 3-9. Reference TM 9-2350-230-24P/1, group 0710, for parts.

- a. Fabricate template in accordance with figure 3-7.
- b. Remove power plant in accordance with section VI, chapter 2, TM 9-2350-230-20-1
- c. Remove insert (view B, fig. 3-8) from left support or right support depending on the side that transmission trunnion cap is to be replaced.
- d. Clean the machined surface of the support, including the insert grooves.
- e. Inspect the insert surface of the support for burr, cracks, and concentricity. Remove burrs. Use base of template (thick section, fig. 3-7) to determine concentricity.
- f. Deleted.

#### **CAUTION**

Transmission trunnion caps are not interchangeable from left side to right side or from one vehicle to another.

- g. Assemble transmission trunnion caps onto the support using four new screws (NSN 5306-00-075-5359).
- h. Place template into the mount assembly (view A, fig. 3-8), with base down and fitted into the machined surface of the support. Top of template (thin section) will lie against side of the transmission trunnion cap.
- i. Inscribe the upper insert circumference onto the transmission trunnion cap by following the perimeter of the template. Remove template.
- j. Inscribe edge of the insert groove onto the front and rear flat mating surfaces of the transmission trunnion cap, lines 1 and 2 shown in view B, figure 3-8.
- k. Inscribe the edges of the support's machined surface (perpendicular to the insert circumference) onto the front and rear flat mating surfaces of the transmission trunnion cap, lines 3 and 4 shown in view B, figure 3-8.
- l. Remove transmission trunnion cap and stamp RR (right rear) or LR (left rear) as appropriate, and the vehicle serial number on the inner rear of the castings as indicated in view B, figure 3-8. The vehicle serial number is located next to the tow eye on the left rear of vehicle.
- m. The transmission trunnion cap is now ready for machining. The machining set-up will be determined by inscribe layout on the transmission trunnion cap. Machining requirements are shown in figure 3-9.

#### **CAUTION**

Trunnion caps are not interchangeable from left side to right side or from one vehicle to another.

- n. Install insert into left support or right support depending upon which cap, left or right, that is being
  - o. Install insert into machined cap.
  - p. Temporarily install new cap assembly onto mating support. Check alignment. Remove cap.
  - q. Install power plant into vehicle in accordance with paragraph 2-20, TM 9-2350-230-20-1. Be sure right and left caps are correctly positioned end-for-end and side-for-side.
  - r. Install caps as follow: Tap the cap with a soft mallet until it is in place. Install the new capscrew and torque to 5 pounds feet. If the clearance between the cap and mount totals .002 to .010 inch, i.e., the sum of the clearance dimensions on each side of the cap, continue to tighten the screws to 193-207 lb-ft. There will be no clearance between the cap and mount if the clearance between the cap and mount is greater than 0.002 inch. Remove the cap and insert shim (12259615) and repeat steps a through c.
  - s. Install lockwire to transmission trunnion caps.





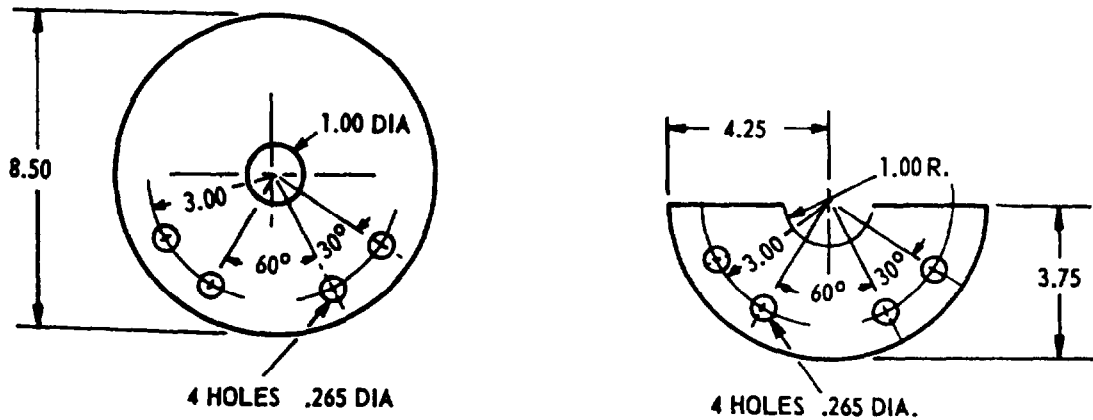

TEMPLATE PLATE  
ALUMINUM .125 IN. THK  
6061 T6  
QQ-A-250/11

BASE PLATE  
ALUMINUM .375  
6061 T6  
QQ-A-250/11

NOTE:  
FINISH MACHINE  
O.D. AFTER  
ASSEMBLY

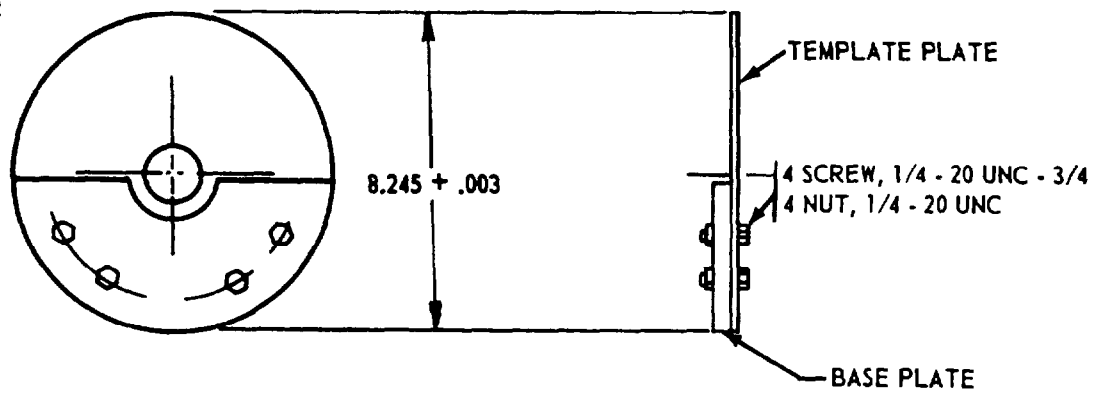

TAO21442

Figure 3-7. Transmission trunnion template assembly.

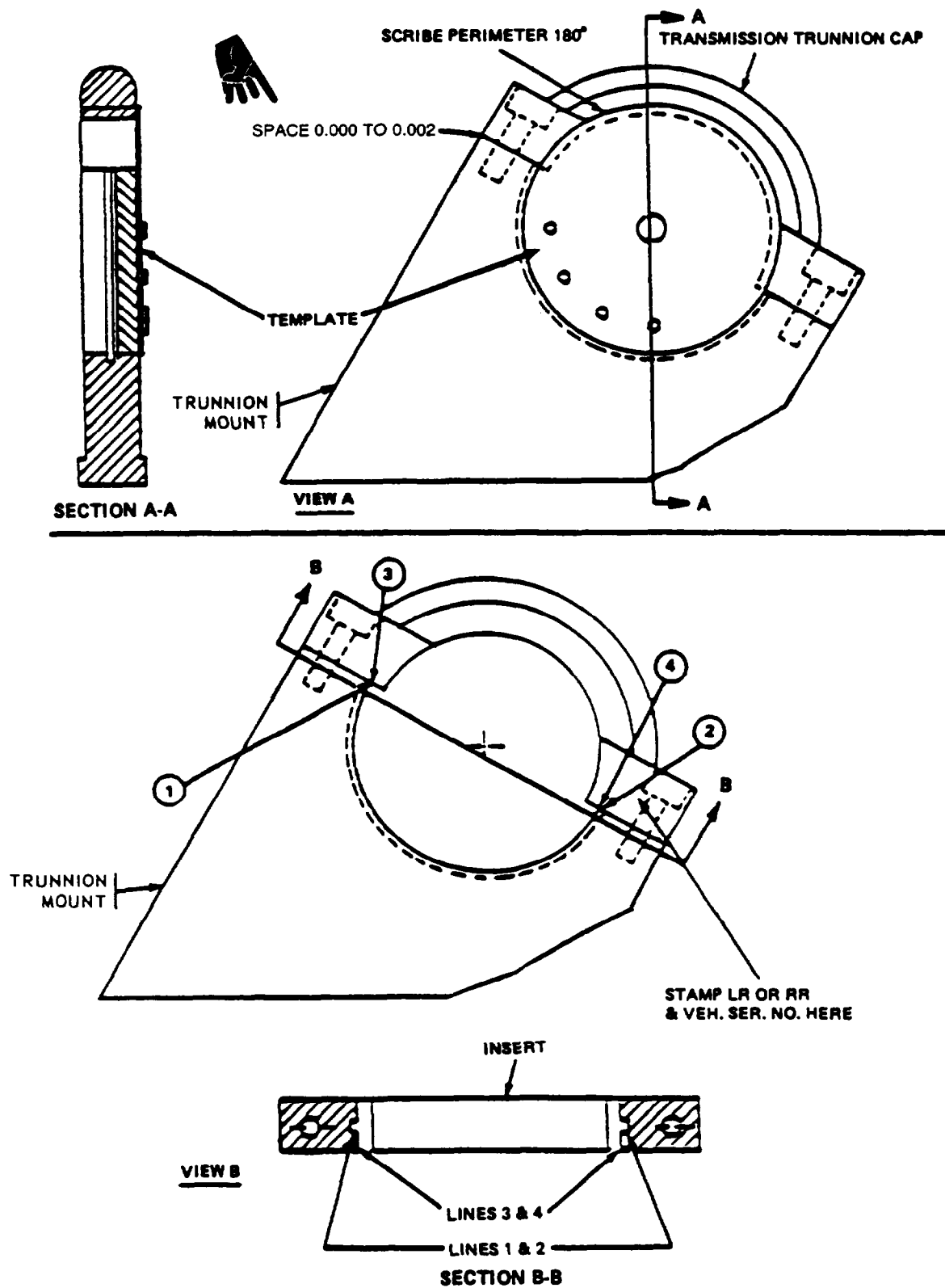

Figure 3-8. Transmission trunnion cap assembly.

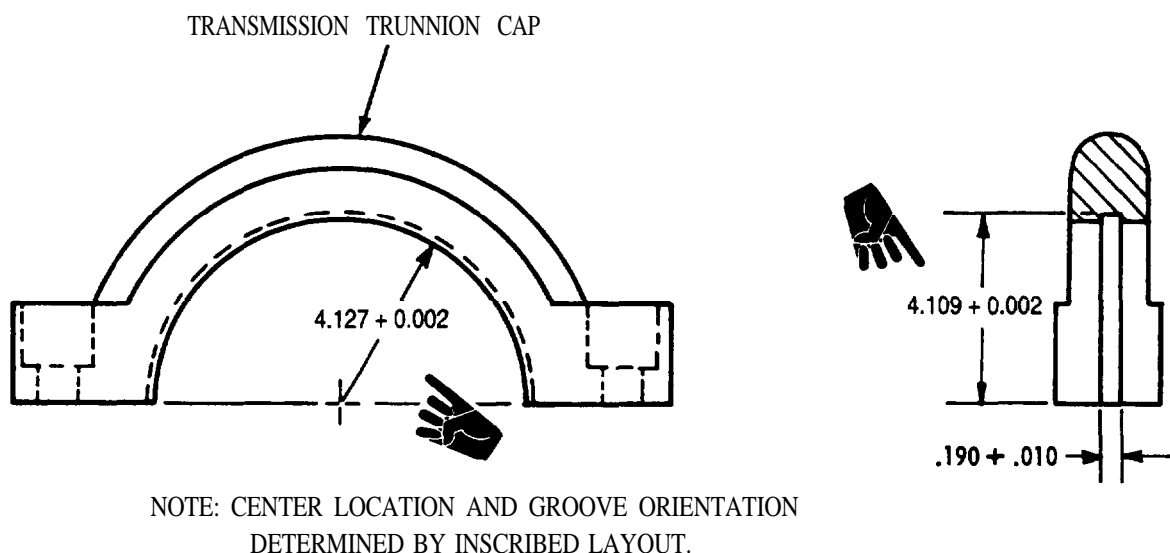

Figure 3-9. Machining requirement for transmission trunnion cap.

### 3-9. Components of Engine and Container Assembly

An unserviceable repairable engine returned to an overhaul depot must include the accessories listed and identified in table 3-1 prior to issuance of a serviceable replacement. The requisitioner must furnish specific justification or authorization to support other than a one-for-one exchange. Refer to TM 9-2350-230-24P/1 for requisitioning information and data. Refer to TM 9-2815-205-34 and TM 9-2815-205-34P for components of engine and container assembly (2815-01-316-6617/57K1002).

Table 3-1. Components of Engine and Container Assembly (2815-00-909-5949/5702927)

NSN/PN/CAGE	Description
4730-00-947-4290	GUIDE, OIL CHECK
2815-00-042-3865	PAN, OIL
2815-00-911-7619	FLYWHEEL ASSY
2815-01-037-5250	HOUSING: FLYWHEEL
2815-00-567-2502	MANIFOLD EXHAUST
2815-00-758-9042	BLOWER ASSY
2815-00-999-5355	ENGINE ASSY, ALUMINUM ENGINE BLOCK
2910-00-781-1354	FILTER, FLUID PRESSURE SECONDARY
2910-00-884-1207	FILTER, FLUID PRESSURE PRIMARY
5995-00-074-1943	WIRING HARNESS AIR HEATER
2920-00-514-0464	STARTER
5945-00-690-2707	RELAY, STARTER SOLENOID
3030-01-301-8013	BELT SET WATER PUMP DRIVE
2930-00-127-2518	PUMP ASSY, WATER
2990-00-789-4865	ACCUMULATOR, AIR HEATER
5995-00-866-9408	LEAD ELECT: AIR HEATER-TO-COIL, HIGH TENSION
2920-00-770-1641	IGNITION UNIT, MANIFOLD HEATER
2950-00-909-5951	TURBOCHARGER
2910-01-016-5501	GOVERNOR, DIESEL ENGINE
4810-00-974-7605	VALVE, SOLENOID: HEATER SUPPLY, SHUT-OFF
6680-00-780-8099	GAUGE ROD CAP, LIQUID LEVEL
6680-00-169-1541	ADAPTER, TACHOMETER DRIVE SHAFT
5654316(70040)	GAUGE, PRESSURE HEATER
8145-00-999-5356	CONTAINER
2920-00-999-2537	HOUSING ASSY-STARTER LEVER
2520-00-891-0332	HOUSING ASSY-STARTER DRIVE
4730-00-470-1791	ELBOW, WATER OUTLET
2815-00-105-9849	HOUSING, THERMOSTAT
2930-00-909-5950	TUBE, WATER BYPASS
3020-00-179-6890	PULLEY, GROOVED
4720-01-020-9915	HOSE, TURBO OIL RETURN
2815-00-074-1932	PLATE, SCUFF, FLYWHEEL
5340-01-344-7782	BRACKET, FILTER, FUEL
5340-00-234-6028	BRACKET, AIR HEATER SOLENOID
5133353(72582)	TUBE AND COVER ASSY, TURBO
5113417(72582)	TUBE ASSY, TURBO
4720-00-994-5787	HOSE TURBO OIL SUPPLY
4710-00-473-0140	TUBE ASSY, METAL
2940-00-131-5586	ADAPTER FILTER ASSY: ENGINE OIL
2940-00-789-4873	FILTER ASSY: ENGINE OIL
5340-00-089-6430	COVER ASSY, VALVE ROCKER ARMS, LEFT
2815-00-921-5376	COVER ASSY, VALVE ROCKER ARMS, RIGHT

Table 3-1. Components of Engine and Container Assembly (2815-00-909-5949/5702927) - Continued

NSN/PN/CAGE	Description
5135734(72582)	COVER ASSY, THERMOSTAT HOUSING
2815-01-014-3141	COVER ASSY, ENGINE UPPER FRONT
2815-01-016-8901	BRACKET, AIR HEATER COIL
5304-01-127-7904	SUPPORT, AIR HEATER COIL
2815-00-921-5358	TRUNNION, ENGINE LOWER FRONT
5198254(72582)	HOUSING, TURBO EXHAUST INLET
4730-01-045-3428	ELBOW, TURBO EXHAUST INLET
2835-01-015-5410	HOUSING, ENGINE AIR INLET
5340-01-045-9177	BRACKET, ANGLE, TURBO SUPPORT
4720-00-010-0284	HOSE, ACCUMULATOR TO VALVE HEATER

Table 3-1.1. Components of Engine and Container Assembly (2815-01-031-6154/5704843)

NSN	Description
2815-01-617-1481	ENGINE ASSY, CAST IRON (OLD)
8145-00-999-4356	CONTAINER, METAL, REUSABLE
5305-01-053-2879	SCREW
5310-00-896-0789	NUT
5340-01-181-6408	CLIP
5310-00-377-5972	WASHER
2520-00-145-1259	KIT, TORQUE CONVERTER TO FLYWHEEL
5340-00-889-8677	CAP
5306-00-075-5359	SCREW
5310-00-866-4417	WASHER
5365-00-560-2166	SHIM

Table 3-1.2. Components of Engine/VEESS and Container Assembly (5705398)

NSN/PN/CAGE	Description
10947063-1(19207)	ENGINE/VEESS ASSY, ALUMINUM
3020-00-179-6890	PULLEY
5310-00-951-2761	WASHER
3020-06-947-2143	CONES
5306-00-999-4231	SCREW
8145-00-999-5356	CONTAINER
5305-01-053-2879	SCREW
5340-01-181-6408	CLIP
5310-00-868-8062	NUT
5310-00-877-5972	WASHER
2520-00-145-1259	KIT, TORQUE CONVERTER TO FLYWHEEL
5340-00-869-8677	CAP
5305-00-075-5359	SCREW
5310-00-866-4417	WASHER
5365-00-560-2166	SHIM

Table 3-1.3. Components of Engine/VEESS and Container Assembly (5705397)

NSN/PN/CAGE	Description
11669078-1(19207)	ENGINE/VEESS ASSY, CAST IRON
3020-00-179-6890	PULLEY
11594086(19207)	CONES
5310-00-951-2761	WASHER
5306-00-999-4231	SCREW
8145-00-999-5356	CONTAINER
5305-01-053-2879	SCREWS
5340-01-181-6408	CLIPS
5310-00-868-8062	NUT
5310-00-877-5972	WASHER
2520-00-145-1259	KIT, TORQUE CONVERTER TO FLYWHEEL
5340-00-889-8677	CAP
5305-00-075-5359	SCREW
5310-00-866-4417	WASHER
5365-00-560-2166	SHIM

**3-10. Components of Transmission and Container Assembly**

An unserviceable repairable transmission returned to an overhaul depot must include the accessories listed and identified in table 3-2 prior to issuance of a serviceable replacement. The requisitioner must furnish specific justification or authorization to support other than a one-for-one exchange. Refer to TM 9-2350-230-24P/1 for requisitioning information and data.

Table 3-2. Components of Transmission and Container Assembly (2520-00-909-2441/5703120(19207))

NSN/PN/CAGE	Description
2520-00-999-3904	TRANSMISSION
3040-00-157-1813	HOUSING ASSY, TORQUE CONVERTER
2520-00-839-6624	HOUSING ASSY, TRANSMISSION END COVER
3040-00-839-6622	HOUSING ASSY, LEFT OUTPUT
2520-00-758-7214	COVER ASSY, TORQUE CONVERTER PUMP
5340-00-911-7629	TRANSMISSION LIFTING BRACKET, LEFT AND RIGHT
3040-00-842-5599	HOUSING ASSY, RIGHT OUTPUT
3040-00-842-5594	COVER ASSY, RIGHT
2520-00-824-5651	COVER, SPEEDOMETER DRIVE
4730-00-840-4711	HOUSING ASSY, OIL FILTER
4820-01-010-5048	BODY ASSY, VALVE, LOCKUP REGULATOR
4820-00-933-5239	BODY ASSY, VALVE MAIN PRESSURE REGULATOR
3040-00-919-7257	BODY ASSY, VALVE, LUBRICATION REGULATOR
5340-00-842-5665	COVER, OIL SUMP
2520-00-051-9929	VALVE ASSY, CONTROL MAIN
2530-01-045-6032	VALVE ASSY, STEER GEAR
2520-00-839-6621	COVER ASSY BEVEL GEAR

**Section III. REPAIR OF FUEL SYSTEM COMPONENTS****3-11. Fuel Tanks**

Fuel tank minor repairs may be made by using epoxy repair procedure presented for coolant radiators (fig. 3-13, sheets 1 and 2). More permanent repairs are made by welding.

**WARNING**

Do not smoke or use open flame when working on fuel system. Explosion may occur, causing severe injury or death.

**CAUTION**

Drain (TM 9-2350-230-10) and clean fuel tanks thoroughly before attemptin any welding repair. Make sure all fuel and fumes have been completely eliminated from tanks and working area. Keep area well ventilated.

**3-12. Detailed References**

*a.* Removal and installation procedures for fuel tanks are illustrated and described in figures 2-8, 2-9, 3-10, and 3-11.

*b.* Removal and installation of fuel system external hoses, valves, and fittings are illustrated and described in TM 9-2350-230-20- 1.

*c.* Removal, installation, and repair of engine-mounted fuel system components are illustrated and described in TM 9-2815-205-34.



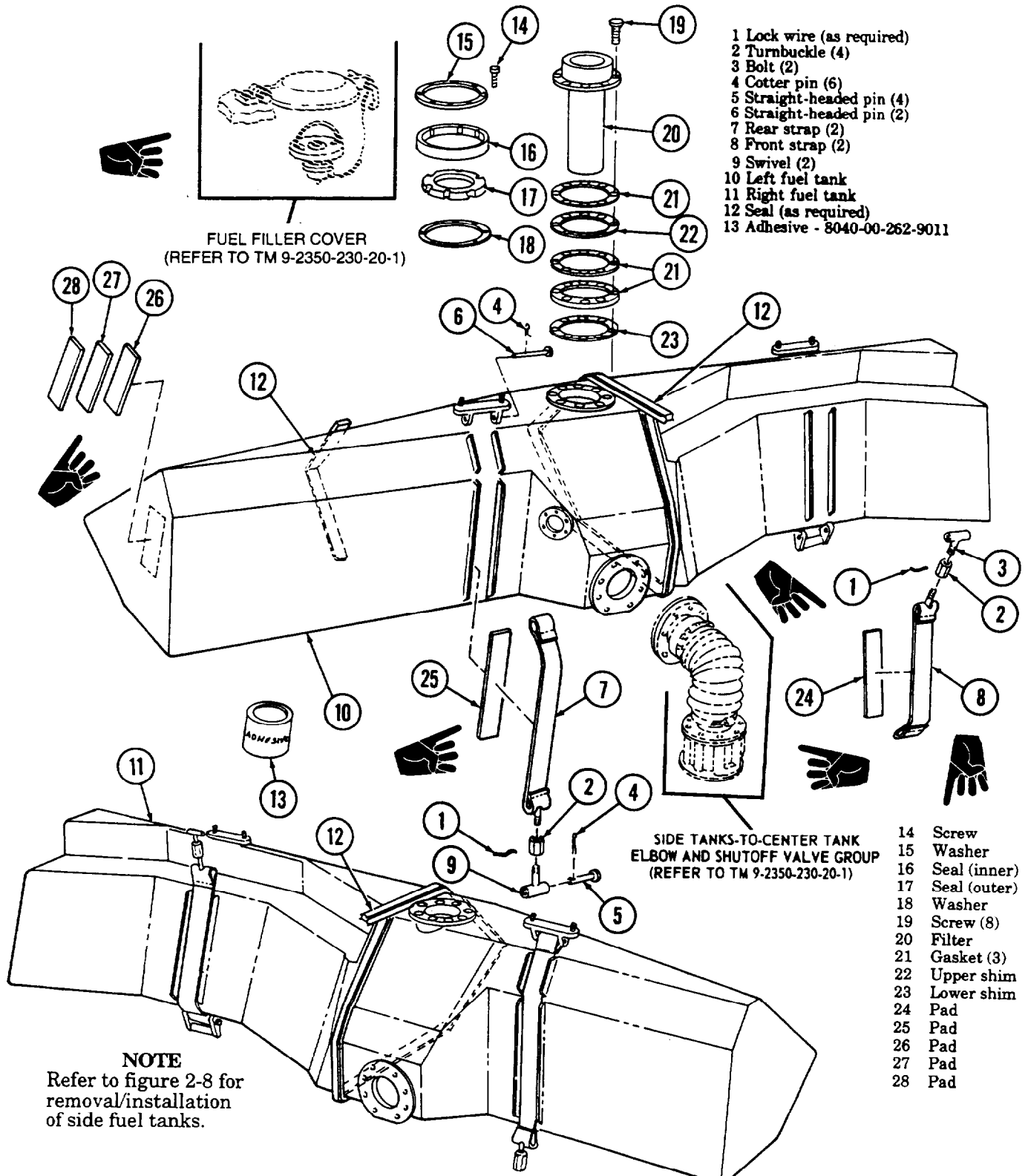
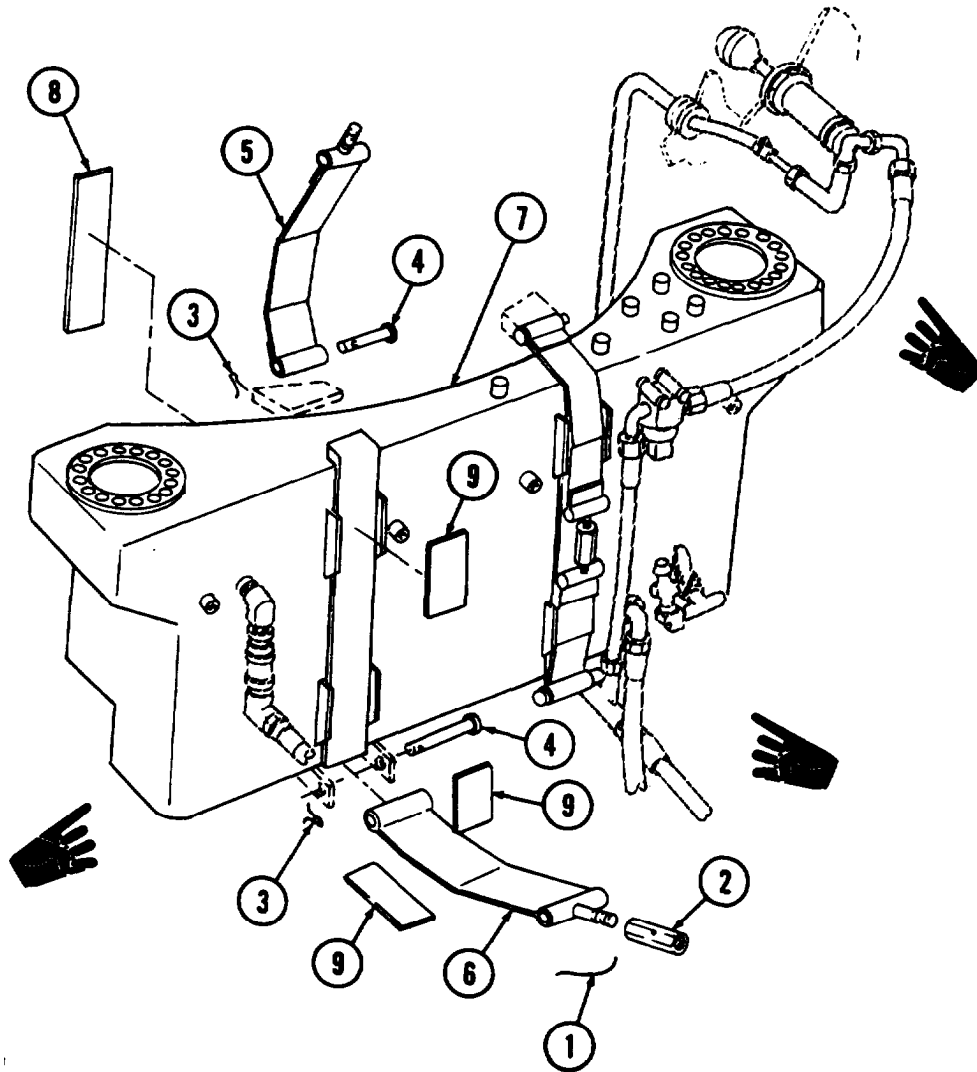

Figure 3-10. Side fuel tanks group — exploded view.



**LEGEND:**

- 1. LOCK WIRE (AS REQUIRED)
- 2. TURNBUCKLE (2)
- 3. COTTER PIN (4)
- 4. STRAIGHT-HEADED PIN (4)
- 5. UPPER STRAP (2)
- 6. LOWER STRAP (2)
- 7. CENTER FUEL TANK
- 8. PAD
- 9. PAD (3)

NOTE: REFER TO TM 9-2350-230-20-1 FOR REMOVAL/INSTALLATION OF DRAIN PUMP, FILTER, VALVES HOSES, AND TUBES.

NOTE: REFER TO: FIGURE 2-9 FOR REMOVAL/INSTALLATION OF CENTER FUEL TANK.

*Figure 3-11. Center fuel tank group — exploded view.*



**Section IV. REPAIR OF COOLING SYSTEM COMPONENTS AND TRANSMISSION OIL COOLER**

**3-13. Scope**

This section describes and illustrates procedures for maintenance of the cooling system components and transmission oil cooler as listed in table 3-3. Calibration of the fan drive-clutch must be done at depot overhaul facilities.

**3-14. References**

a. Removal and installation procedures for cooling system components and transmission oil cooler are described in TM 9-2350-230-20-1.

b. Maintenance of the water pump, engine oil cooler, and engine internal cooling components is described in TM 9-2815-205-34.

Table 3-3. Engine and Transmission Cooling System Components

Component	Figure reference
Fan clutch shaft bearing retainer assembly	3-12
Radiator and transmission oil cooler	3-13
Cooling-fan system	3-14 through 3-47

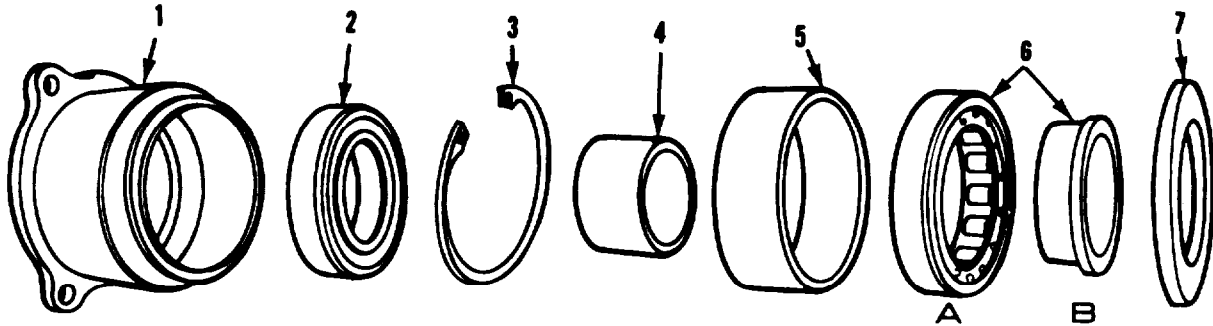

LEGEND

- 1. BEARING RETAINER - 10956019
- 2. BALL BEARING - 11602332
- 3. RETAINING RING - MS16631-3334
- 4. SPACER, SLEEVE - 11636362
- 5. SPACER, SLEEVE - 11636363
- 6. ROLLER BEARING - MS19078-12
  - A. OUTER RACE
  - B. INNER RACE
- 7. SEAL, PLAIN ENCASED - 11601474

TA019745

Figure 3-12. Fan clutch shaft bearing retainer assembly.

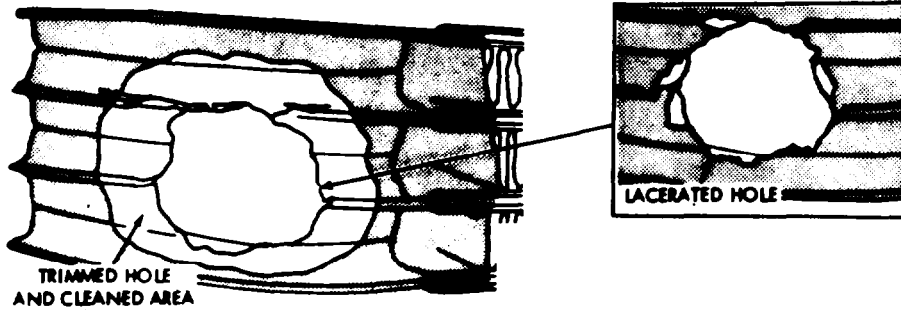

**TRIMMED HOLE AND CLEANED AREA**

A. TRIMMING AND CLEANING DAMAGED MEA.

NOTE. REPAIR OF HOLES LARGER THAN ONE INCH IN DIAMETER IS NOT RECOMMENDED.

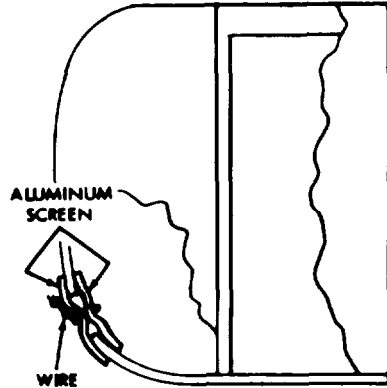

B. WIRING ALUMINUM SCREENING TO DAMAGED AREA

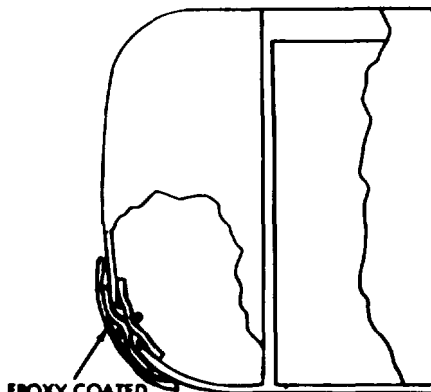

**EPOXY COATED GLASS CLOTH**

C. APPLYING GLASS CLOTH AND EPOXY MIXTURE TO DAMAGED AREA.

REPAIR PROCEDURE END TANKS

1. TRIM AWAY ALL RAGGED EDGES AND CLEAN AREA WITH A WIRE WHEEL (VIEW A). BLOW AWAY DUST AND CLEAN REPAIR AREA WITH NAPHTHA FOLLOWED BY DENATURED ALCOHOL. PRESENCE OF OIL IN REPAIR AREA WILL RESULT IN POOR ADHESION.
2. CUT TWO PIECES OF ALUMINUM SCREENING SLIGHTLY LARGER THAN HOLE AND WIRE TOGETHER SO RADIATOR MATERIAL IS SANDWICHED BETWEEN SCREENING (VIEW B).
3. PREPARE A PROPER AMOUNT OF EPOXY RESIN AND HARDENER 8040-00-738-6429.

NOTE. BE CERTAIN TO READ INSTRUCTIONS SUPPLIED WITH KITS

WARNING: MATERIALS MAY CAUSE SKIN IRRITATION. IF CONTACT OCCURS WASH THOROUGHLY WITH SOAP AND WATER. USE ADEQUATE VENTILATION.

4. THOROUGHLY SATURATE SCREENING WITH EPOXY MIXTURE.
5. CUT A PIECE OF GLASS CLOTH LARGER THAN HOLE, SATURATE WITH EPOXY MIXTURE, AND FORM OVER HOLE AND CLEANED SURROUNDING AREA (VIEW C). FOR HOLES LARGER THAN 1/2-INCH DIAMETER, A SECOND CLOTH LAYER IS RECOMMENDED AND AN ADDITIONAL CEMENT KIT MAY BE REQUIRED. PLACE A PIECE OF RELEASE FILM ON SECOND PATCH AND WITH HARDWOOD DEPRESSOR, WORK OUT TRAPPED AIR POCKETS BY WORKING FROM CENTER OF PATCH OUTWARDS.
6. APPLY ANOTHER COAT OF EPOXY MIXTURE OVER GLASS CLOTH.
7. ALLOW PATCH TO SET UNDISTURBED FOR 16 TO 24 HOURS.

NOTE. CURE WILL BE SLOW IN TEMPERATURES BELOW 70°F. CURE MAY BE EXPEDITED TO ABOUT FOUR HOURS BY PLACING HEAT LAMP OVER PATCH AREA AND GRADUALLY INCREASING HEAT INTENSITY BY MOVING LAMP CLOSER TO REPAIR AREA.

CAUTION: REPAIR AREA TEMPERATURE MUST NOT EXCEED 100°F. FOR THE FIRST TWO HOURS OF CURE AND 250°F. ANY TIME THEREAFTER. MINIMUM DISTANCE BETWEEN HEAT LAMP AND REPAIR AREA IS TWO FEET REGARDLESS OF TEMPERATURE REQUIREMENT.

8. FOR RADIATOR OR TRANSMISSION OIL COOLER TEST, SEE FIGURE 3-13/(2 of 2)

TA178474

Figure 3-13. Repair of aluminum radiator or transmission oil cooler (1 of 2)

TO THERMOSTAT HOUSING

**NOTE**

RADIATOR SHOWN; TRANSMISSION OIL COOLER IS SIMILAR IN APPEARANCE AND CONSTRUCTION AND IS REPAIRED IN SAME MANNER.

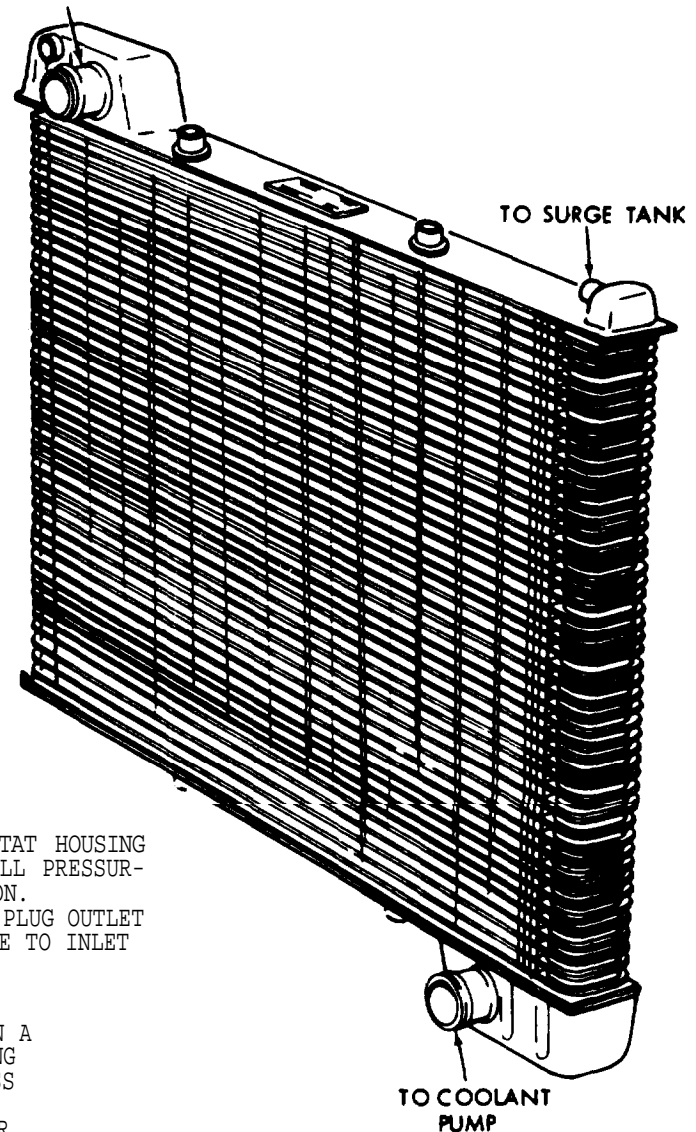
**TEST**

1. TO TEST RADIATOR REPAIR, BLOCK THERMOSTAT HOUSING AND COOLANT PUMP CONNECTIONS AND INSTALL PRESSURIZING EQUIPMENT TO SURGE TANK CONNECTION.
  - 1.1 TO TEST TRANSMISSION OIL COOLER REPAIR, PLUG OUTLET CONNECTION AND INSTALL PRESSURIZING HOSE TO INLET CONNECTION.

**CAUTION**

DO NOT TEST ALUMINUM UNITS IN A TANK THAT HAS BEEN OR IS BEING USED FOR TESTING COPPER/BRASS RADIATORS. FLUXES USED IN COPPER/BRASS RADIATOR REPAIR CONTAMINATE WATER IN TEST TANK, WHICH ATTACKS ALUMINUM.

2. APPLY 18 PSI FOR A PERIOD OF THREE MINUTES WHILE UNIT IS IMMERSSED IN WATER.
3. ABSENCE OF AIR BUBBLES DENOTES A SATISFACTORY REPAIR.

TA178475 ■

Figure 3-13. Repair of aluminum radiator or transmission oil cooler (2 of 2).

### **3-15. Fabricated Tools for Cooling-Fan System**

All disassembly and assembly operations described in these procedures utilize fabricated tools in conjunction with the hydraulic press. Each fabricated tool is identified and keyed to pertinent operations. Careful handling of the cooling-fan system and its components is emphasized throughout the instructions. The use of

hammer and punch is specifically avoided. The required fabricated tools are:

- a. Fabricated support (fig. 3-14).
- b. Fabricated remover/installer (fig. 3-16).
- c. Fabricated plug (C, fig. 3-16).
- d. Fabricated spacer (A, fig. 3-16).
- e. Fabricated alignment screws (B, fig. 3-16).

**FABRICATED SUPPORT**  
**MATERIAL: SHEET ALUMINIUM**  
**1/4 IN. PLATE**

NOTE: ALL DIMENSIONS SHOWN  
 ARE IN INCHES.

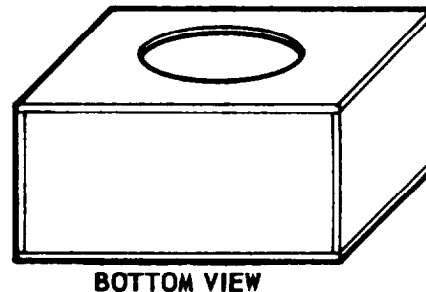
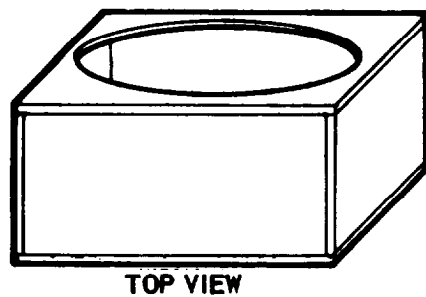
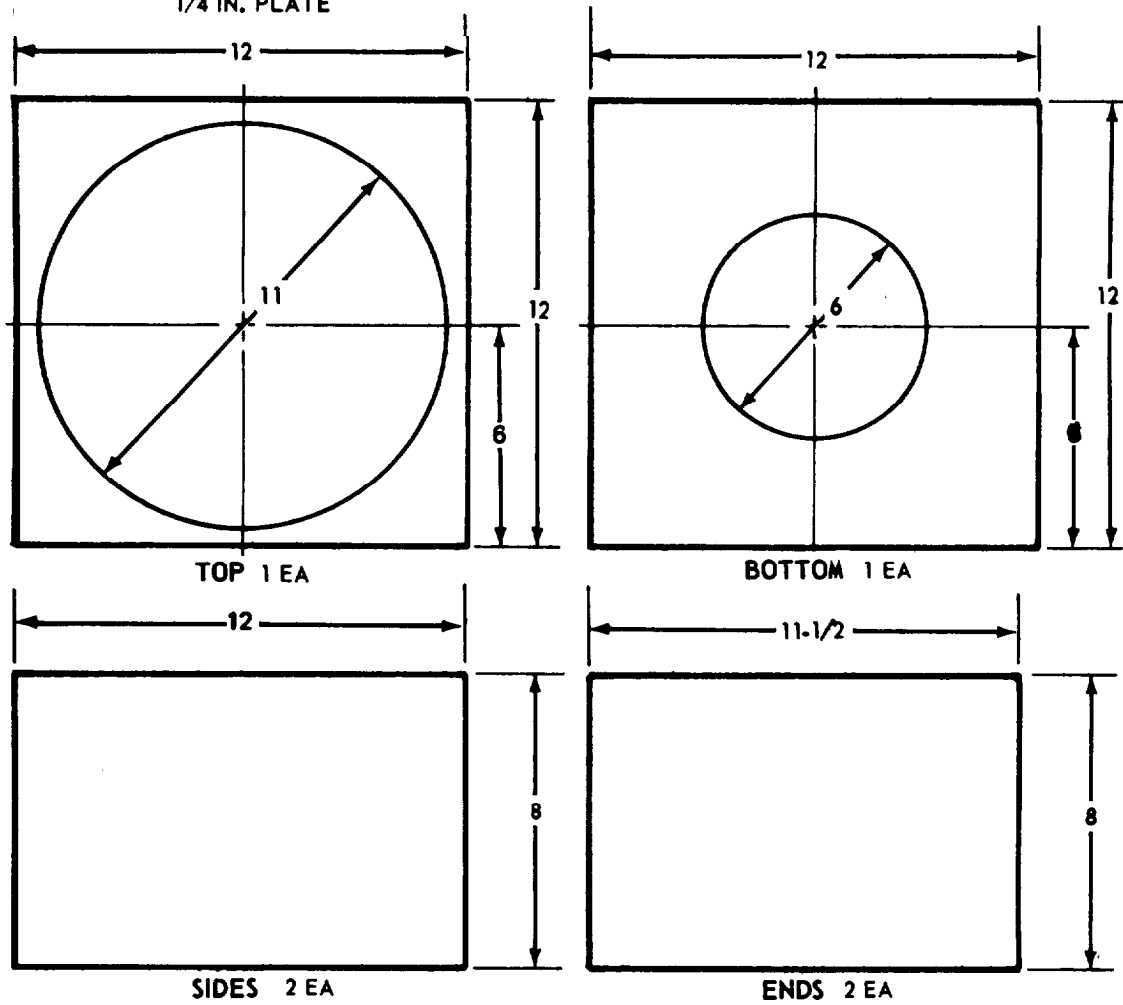

TA019714

Figure 3-14. Fabrication instructions for disassembly/assembly support

**FABRICATED REMOVER/INSTALLER**  
MATERIAL: COLD ROLLED STEEL

NOTE: ALL DIMENSIONS SHOWN  
ARE IN INCHES

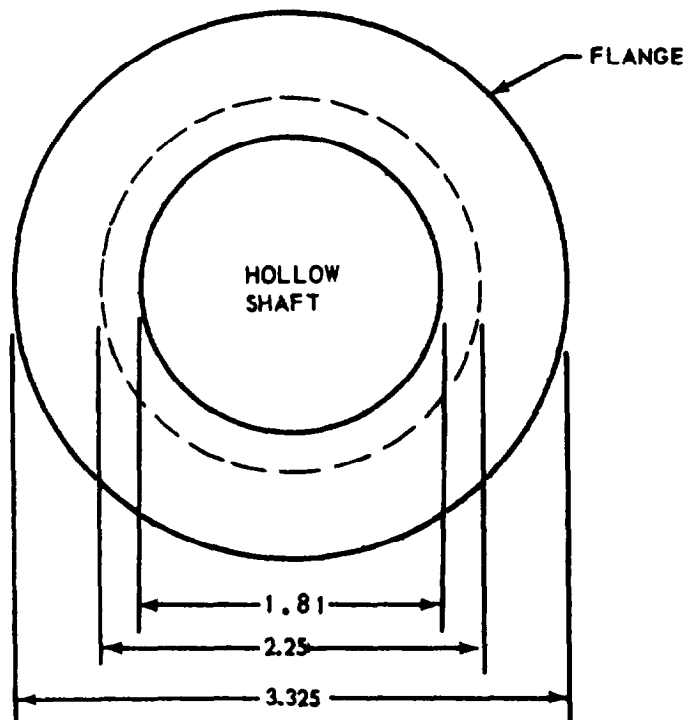
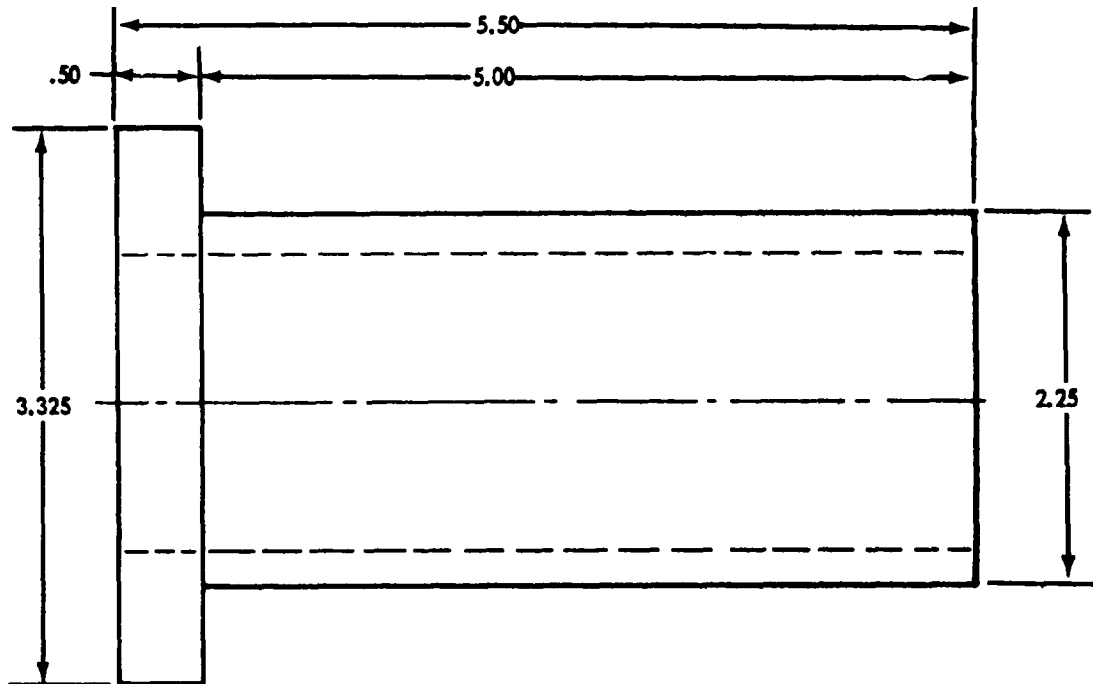

TA019740

Figure 3-15. Fabricated remover/installer.

**A - FABRICATED SPACER**

MATERIAL:  
ALUMINUM TUBING,  
1/4 IN. STOCK

NOTE: ALL DIMENSIONS SHOWN  
ARE IN INCHES.  
BEVEL SIDES OF THE 3 EACH  
3/4-INCH SLOTS TO 45°.

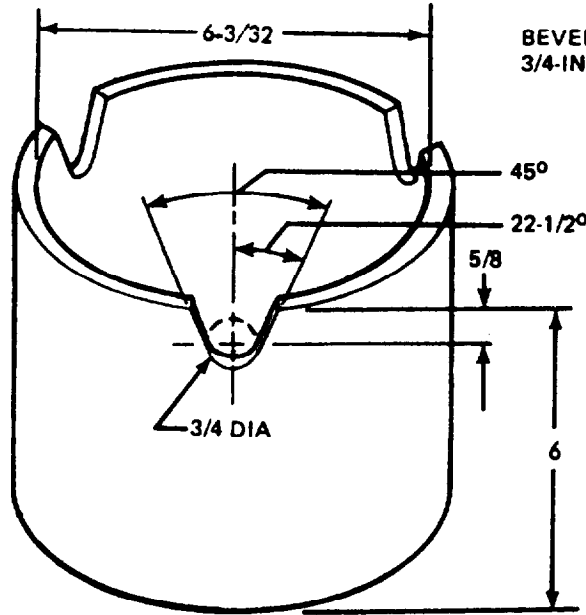

3 SLOTS; SPACED 120°, BEVEL AS SHOWN

**B - ALIGNING STUDS (3)**

MATERIAL: STEEL BOLT,  
3/8 - NF24X4

NOTE: ALL DIMENSIONS SHOWN  
ARE IN INCHES.

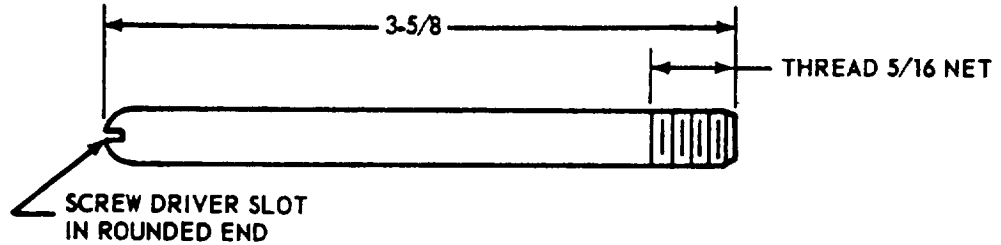

**C - FABRICATED PLUG**

MATERIAL: COLD ROLLED STEEL

NOTE: ALL DIMENSIONS SHOWN  
ARE IN INCHES.

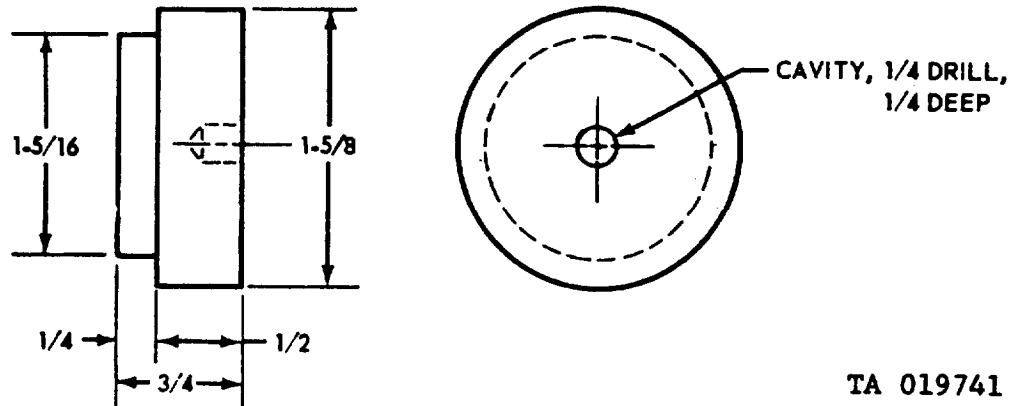

Figure 3-16. Fabricated tools.

TA 019741

**3-16. Cooling-Fan System (Rotor, Stator, Clutch, Retainer, Bearings and Drive-Pulley Assembly)**

a. The complete cooling-fan system is removed by the using organization and evacuated to the direct support maintenance unit for a direct exchange (DX) basis.

b. The complete cooling fan-system is replaced on a DX basis at the direct support maintenance level when a DX float is maintained. When immediate replacement is not available from DX stock, the unserviceable cooling-fan system is evacuated to the authorized repair facility at the depot maintenance level.

c. When removed from the power pack at the organizational maintenance unit, the cooling-fan system must be complete as shown in figures 3-17 and 3-18. Items of importance are as follows.

(1) Sensitive components requiring care in handling are keynoted in the front view of the removed cooling-fan system as detailed in figure 3-17.

(2) The rear view of the removed cooling-fan system shown in figure 3-18 shows the minimum protection of the heat-transfer element and temperature-control unit when the system is placed on dunnage.

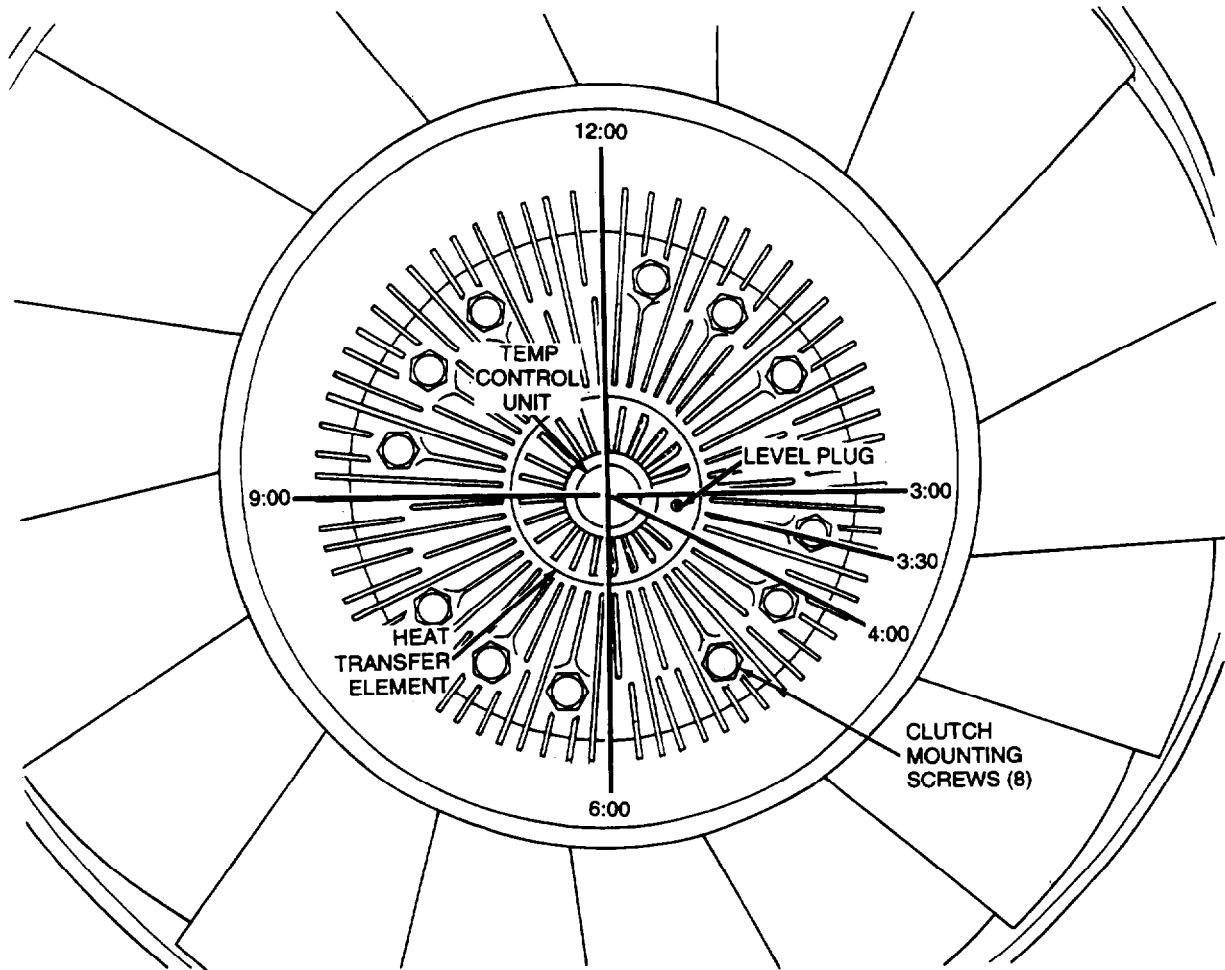

*Figure 3-17. Front view of cooling-fan system.*



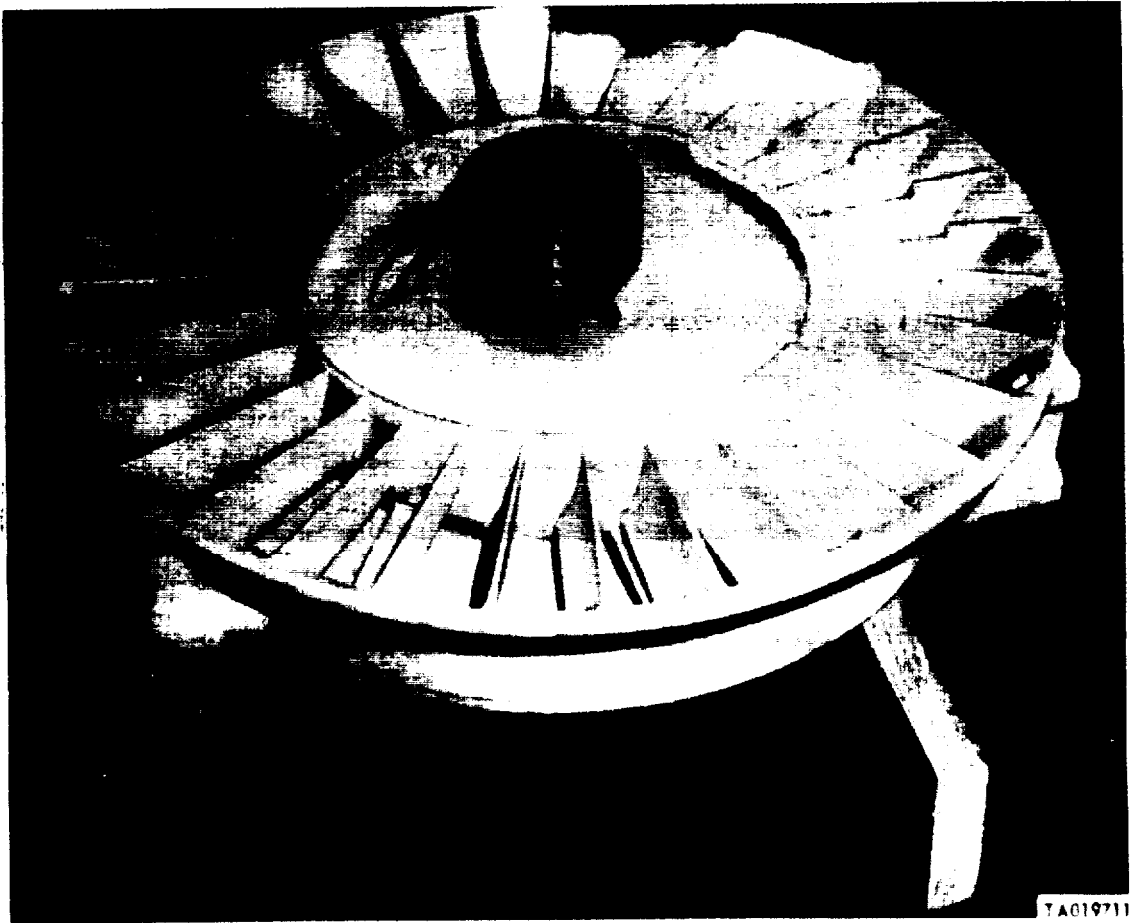

Figure 3-18. Rear view of cooling-fan system resting on dunnage.

d. Care in handling of serviceable/unserviceable cooling-fan system when it is removed from the power pack should be emphasized in the internal/external maintenance SOP's to include the following:

(1) Proper handling of the cooling-fan system during DX processing, transporting, or storage can be

achieved by using a fabricated crate as shown in figure 3-19 and as constructed in figure 3-20.

(2) Proper handling during storage at the DX facility or while awaiting parts at the repair facility requires minimum protection by the use of dunnage as shown in figure 3-18.

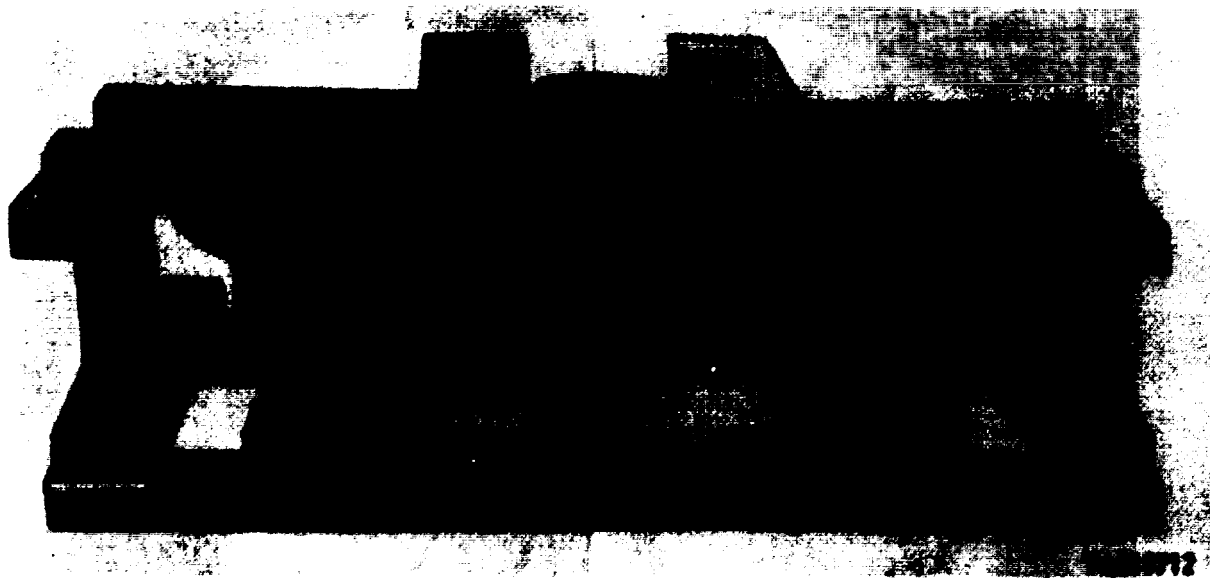

Figure 3-19. Cooling-fan system enclosed in protective crate

**F - FABRICATED PROTECTIVE CRATE**

NOTE: ALL DIMENSIONS SHOWN ARE IN INCHES.

MATERIAL: (a) WOOD 2 X 4 STOCK  
 (b) 2 EA STEEL BOLTS, 1/2 X 12,  
 WASHERS AND NUTS

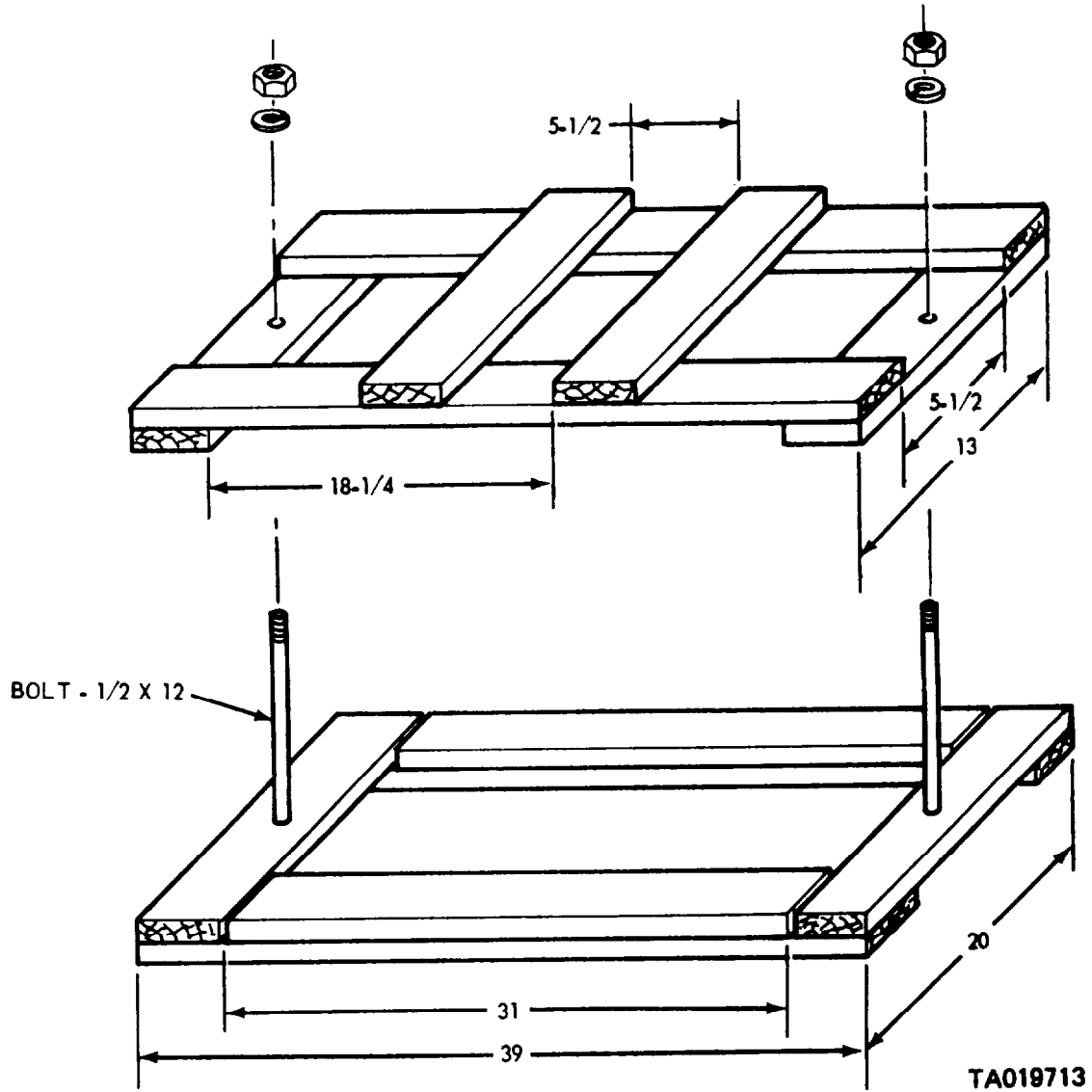

Figure 3-20. Fabricated protective crate

### 3-17. Cooling-Fan System Disassembly - Removal of Drive Pulley.

a. Place the square fabricated support (fig. 3-14) on shop floor with 11-inch opening up.

b. Place the cooling-fan system (drive pulley up) on fabricated support with fan clutch centered in the 11-inch opening, and install required removal tools as shown in figure 3-21. The following steps and specified tools are required to remove the pulley, using three men.

(1) Engage fan-clutch lockup device as shown at E, figure 3-22.

(2) Disengage key washer tab from retaining nut slot.

(3) Install spanner wrench 5120-00-907-0698 in hollow clutch-shaft and over pulley retaining nut as shown at A, figure 3-21.

(4) Install open-end, adjustable wrench 5120-00-449-8084 on spanner wrench as shown at B, figure 3-21.

(5) Install HD break-over wrench (or HD ratchet) 3/4-inch drive, with 7/8-inch HD socket on spanner wrench as shown at C, figure 3-21.

(6) While one man holds stationary the locked-up fan system and a second man holds wrench C, figure 3-21, a third man pulls counterclockwise on adjustable wrench B, figure 3-21, to remove the pulley retaining nut (use pipe extension on wrench B if required).

(7) Remove all tools. Remove the pulley retaining nut and washer. Prepare to remove pulley in next step.

c. Removal of One-Piece Pulley. With pulley retaining nut and key washer removed, attach fabricated plug and puller for removal of drive pulley (fig. 3-23) as follows:

(1) Install fabricated plug (C, figure 3-16) in hollow clutch shaft as shown at A, figure 3-23. Fill the 1/4-inch plug cavity (top center of plug) with oil or grease

(2) Attach HD puller with 18-inch jaws (component of puller kit, 5120-00-423-1596) as shown at B, figure 3-23.

(3) Using desired hand tools, turn puller screw clockwise to remove pulley.

(4) If pulley fails to move under normal pull, it may be necessary to apply heat for expansion of the pulley.

#### CAUTION

Apply heat uniformly around outer area of pulley only. Maintain steady pull on the puller screw during heat application.

(5) Dispose of pulley.

(6) Remove pulley drive key (Woodruff) from clutch shaft and retain for use in assembly operation.

d. Removal of Multi-Piece Pulley. With pulley retaining nut and key washer removed, remove four screws and continue as follows:

(1) Install fabricated plug (C, figure 3-16) in hollow clutch shaft as shown at A, figure 3-23. Fill the 1/4-inch plug cavity (top center of plug) with oil or grease

(2) Attach heavy duty puller with 18-inch jaws (component of kit 5120-00-423-1596) as shown at B, figure 3-23

(3) Using required hand tools, turn puller-screw clockwise to remove pulley.

(4) Wedge open the slit on side of bushing to loosen it from the clutch shaft (be careful not to damage the shaft). Remove bushing.

(5) Remove spacer from shaft and drive seal.

(6) Remove pulley drive-key (Woodruff) from clutch shaft and retain for use in assembly operation.

### 3-18. Cooling-Fan System Disassembly - Removal of Clutch from Rotor and Retainer Bearings (and/or Clutch and Retainer from Stator)

a. With drive pulley and pulley drive-key removed, invert the cooling-fan system and rest on the square fabricated support with heat transfer element up. Refer to figure 3-17, and remove the eight clutch-mounting screws (3/8-NC X 3-inches) 5305-00-846-5703 and eight flat washers 5310-00-877-5972 from the clutch cover.



Figure 3-21. Removed cooling-fan System mounted on support for pulley removal



Figure 3-22. Stator slot showing lockup device disengaged and engaged



Figure 3-23. Colling-fan system on support ready for removal of pulley

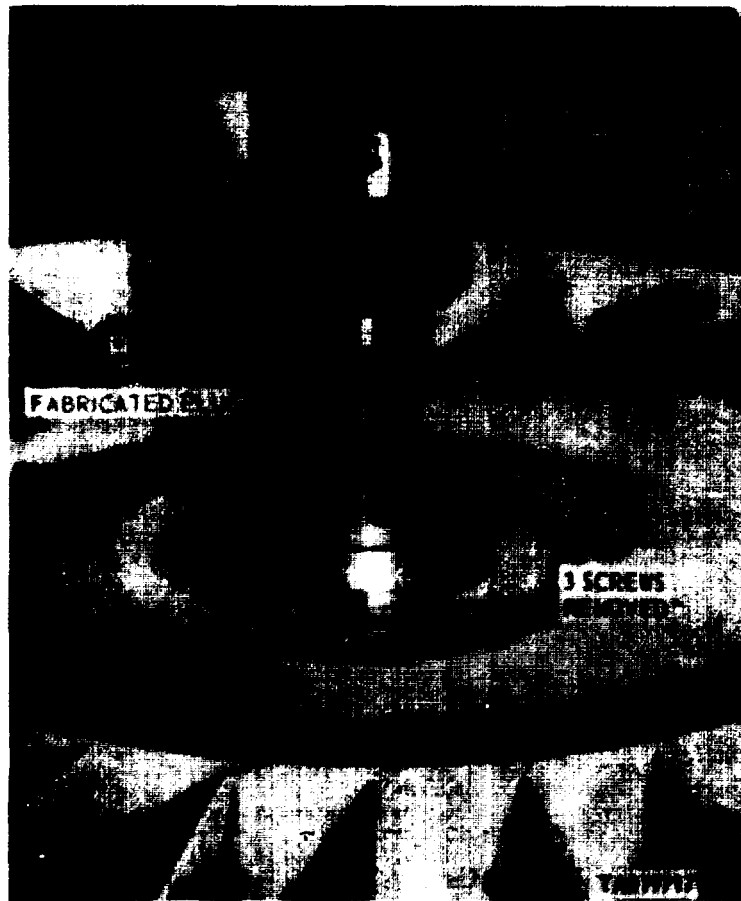

Figure 3-24. Cooling-fan system (pulley and drive key removal) on support in press for of clutch.

**NOTE**

All screws as specified herein are critical in size, length, and type of thread for correct assembly and torque requirements.

Place the square fabricated support on hydraulic press bed with the 11-inch opening up. Place padding (packing material or rags) inside the support. Place cooling-fan system on support with the fan clutch centered on the 11-inch opening for pressing operation as follows:

(1) Remove the three retainer-mounting screws (3/8-NF X 2 1/4 inches) 5305-00-269-3243 and three flat washers 5310-00-877-5972 at A, figure 3-24.

(2) Place the fabricated plug (C, fig. 3-16) in hollow clutch shaft at B, figure 3-24.

(3) Center the square support on press bed and pressing ram with fabricated plug.

(4) Operate press pump with slow, steady strokes.

**NOTE**

At first application of pressure, the clutch housing will be separated from the rotor, allowing the stator to rest on the rotor.

(5) Continue the pressing operation with slow, steady strokes. The clutch shaft will now move through the retainer bearings; or, the retainer will separate from the stator, whichever movement offers the least

resistance.

(6) Continue the pressing operation until the clutch assembly or the clutch with retainer and bearings still on the shaft, drops to the bottom of the support cavity. The padding protects the clutch from damage when it drops.

(7) Release hydraulic pressure on press. Remove stator or stator and retainer from the square support. Remove rotor from support. Remove clutch or clutch with retainer from support.

b. Removal of Tight Retainer. If the clutch shaft is removed from retainer bearings during pressing operation at figure 3-24; and, the tight retainer remains in the stator as shown at figure 3-25, the following instructions apply:

(1) To avoid breakage of the stator casting during pressing operation to remove the tight retainer shown at A, figure 3-25, correct support of the stator on hydraulic press bed is essential. Correct press-bed support is achieved by use of the round fabricated spacer shown at B, figure 3-25. Construction of the spacer is detailed at A, figure 3-16.

(2) Place the square support on press bed with 6-inch opening up.



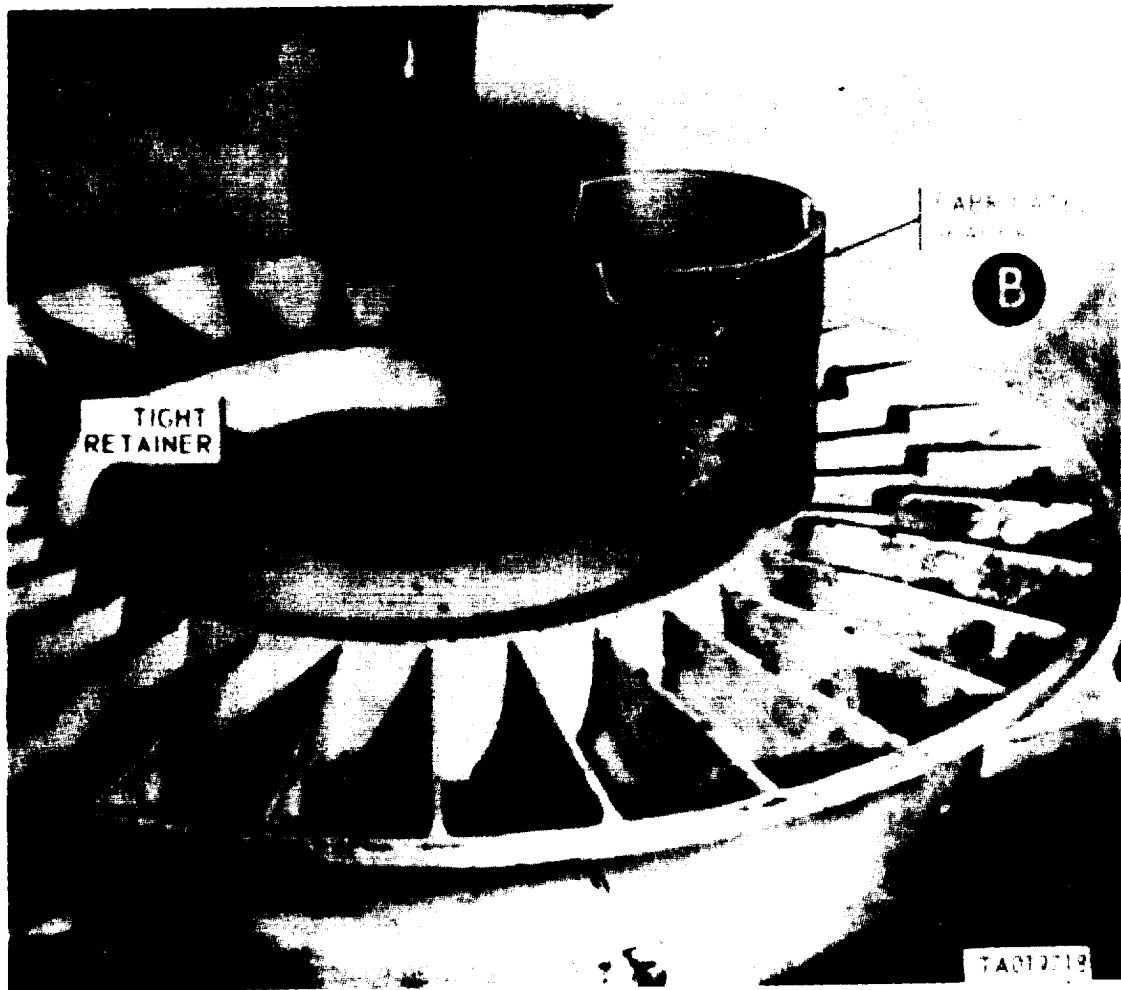

Figure 3-25. Preparation for removal of tight retainer.

(3) Place round spacer (B, fig. 3-25), with slotted end up, on top of the square support. Center the spacer over the 6-inch opening in the square support.

(4) Place stator with tight retainer on round spacer. While firmly holding the spacer in place, rotate the stator until three cast ribs (underside) engage with the three slots in the spacer.

(5) With stator ribs engaged in spacer slots and spacer centered on the 6-inch opening of the square support, center the support on press bed and center the pressing ram with retainer opening. Place pressing block over retainer opening as shown in figure 3-26.

(6) Operate press cautiously with slow, steady strokes to remove retainer from stator. The retainer

will drop into the support cavity.

(7) Release hydraulic pressure. Remove pressing block. Remove stator, spacer, and support from press bed.

c. Removal of Bearings with Retainer from Clutch Shaft If the clutch, retainer, and bearings (shown in fig. 3-27) are removed from the stator during the pressing operation (fig. 3-24), the following instructions apply to removal of bearings and retainer:

(1) Place the square support, with 6-inch opening up, on press bed, on work bench, or on the shop floor.

(2) Place the clutch assembly with bearings and retainer, shaft up, on square support as shown in figure 3-27.



Figure 3-26. Removal of tight retainer from stator.

(3) Place fabricated plug (C, fig 3-16) in hollow end of clutch shaft as shown in figure 3-27. Apply lubricant (oil or grease) to plug cavity (puller screw contact point).

(4) Install puller with 18-inch jaws (from puller

kit 5120-00-423-1596) as shown in figure 3-27.

(5) Using suitable hand tools, turn puller screw clockwise to remove retainer with two bearings and spacer(s) from clutch shaft.

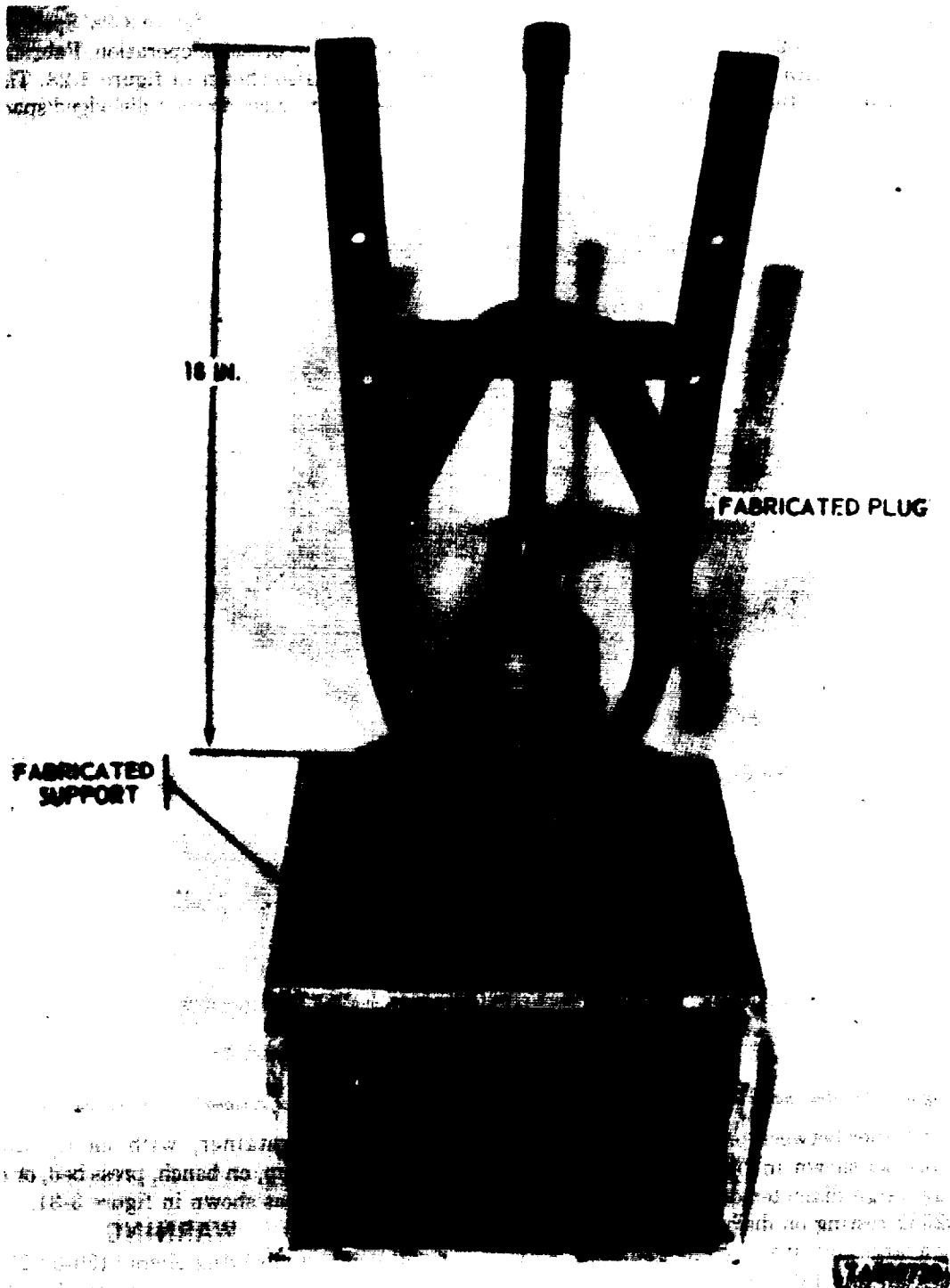

Figure 3-27. Removal of retainer with bearings from clutch shaft

**3-19. Cooling-Fan System Disassembly -  
Removal of Bearings, Lockring,  
Spacer(s), and Seal from Retainer**

**NOTE**

Information in this paragraph details the removal of retainer components with the retainer disassembled from the stator.

Procedures for removal of retainer components when the serviceable retainer is not disassembled from the stator are identical but not illustrated.

- a. Removal of Retainer Seal, Rear Ball Bearing and Spacer. This removal is detailed below:

(1) Seal 5330-00-930-3108 has already been removed for the purpose of illustrating the identity of obsolete ball bearing, 11602333, in figure 3-28. This seal should be removed with the hearing during pressing operation as shown in figure 3-29.

(2) Using a large screw driver or prybar dislodge

obsolete spacer, 10956017, by pushing it against retainer wall as shown in figure 3-28. Spacer will be used as a remover in pressing operation. Fabricated plug (C, fig. 3-16) is also shown in figure 3-28. This plug will also be used to push against dislodged spacer in pressing operation

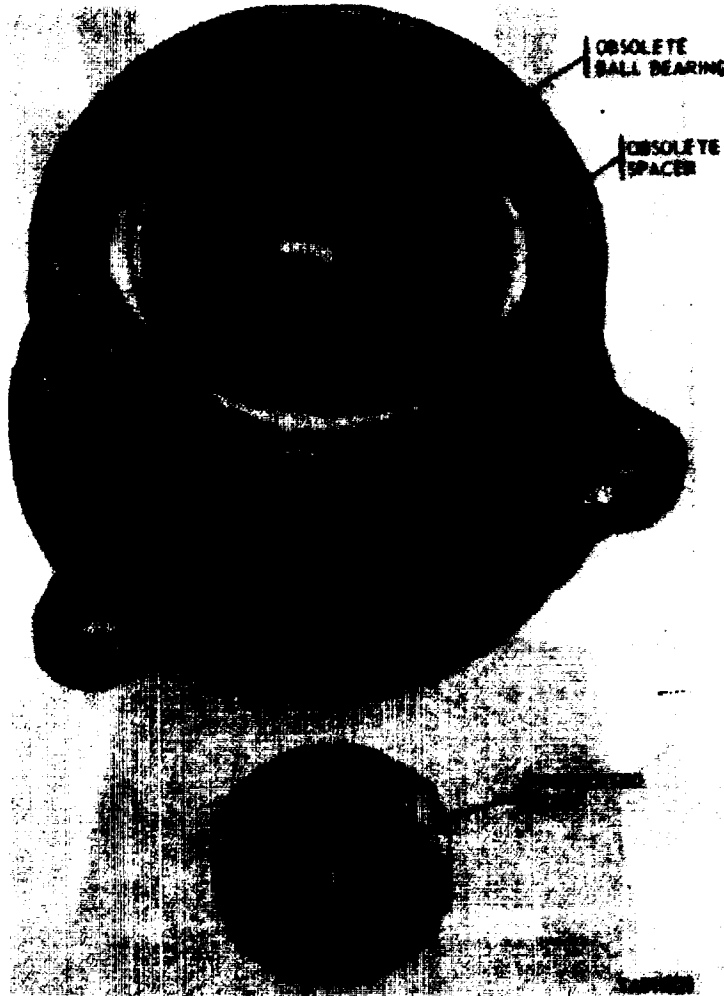

Figure 3-28. Retainer with seal removed showing obsolete spacer (dislodged for removal of obsolete bearing)

(3) Place retainer between pressing blocks on hydraulic-press bed as shown in figure 3-29. Place the fabricated plug, large diameter down, through sealed bearing 11602332 resting on dislodged spacer.

(4) Using a large bolt, shaft, or other suitable drift between press ram and fabricated plug as shown in figure 3-29, press obsolete spacer 10956017, obsolete bearing 11602333, and old seal 5330-00-930-3108 from retainer cavity. Discard all three items.

(5) Clean the retainer cavity to locate lockring 5365-00-999-4291 as shown in figure 3-31.

(6) Place retainer, with cavity and exposed lockring facing up, on bench, press bed, or other suitable flat surface as shown in figure 3-31.

**WARNING**

Heavy duty lockring pliers 5120-00-293-0186 must be used to remove lockring in next step.

(7) Install lockring pliers 5120-00-293-0186 with offset tips against retainer wall as shown in figure 3-32. Be sure that tips are fully engaged in openings of the lockring.

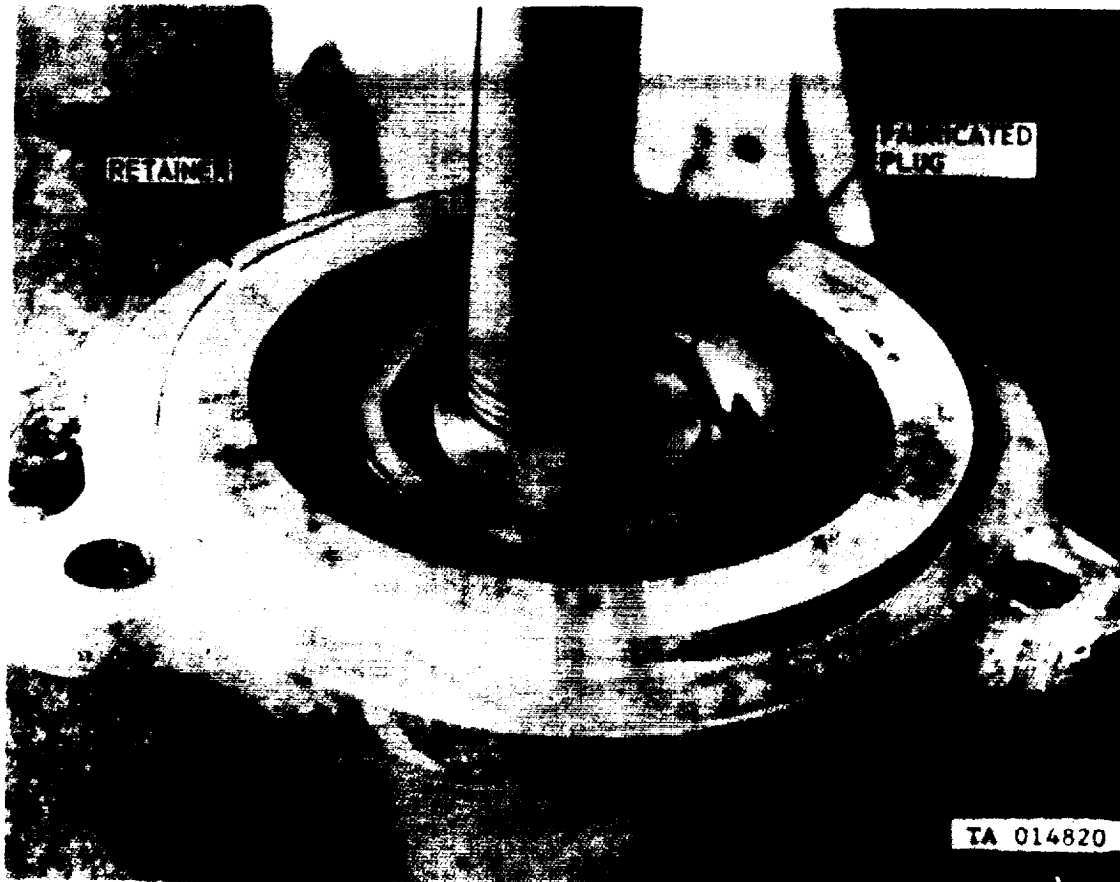

Figure 3-29. Retainer with bearing mounted in press-bed blocks for removal of obsolete bearings, using fabricated plug (inverted for this step).

(8) After lockring is compressed and pliers are locked, cover retainer cavity with a cloth before removing the lockring. The cloth will catch the lockring in case it becomes disengaged from the pliers. Move the compressed lockring and locked pliers (still covered with protective cloth) to shop floor. Place lockring flat on shop working area and carefully release lockring lever on pliers to relieve tension on lockring. Remove lockring from pliers. Remove protective cloth.

(9) With lockring removed, place retainer between pressing blocks on hydraulic press bed as shown in figure 3-33 to remove front (sealed) bearing 11602332 from retainer.

(10) Place fabricated remover installer (fig. 3-15)

with sleeve end down between sealed bearing inner race and press ram as shown in figure 3-33.

(11) With retainer secured between pressing blocks, and remover installer properly aligned between the sealed bearing and the hydraulic press ram, apply pressing action.

#### CAUTION

When the sealed bearing has moved approximately 1/2-inch it will fall into an unbored area of the retainer cavity and the hydraulic pressure will vary momentarily. Use extreme care when pressing actions resume to insure correct alignment of bearing with the second bored area.

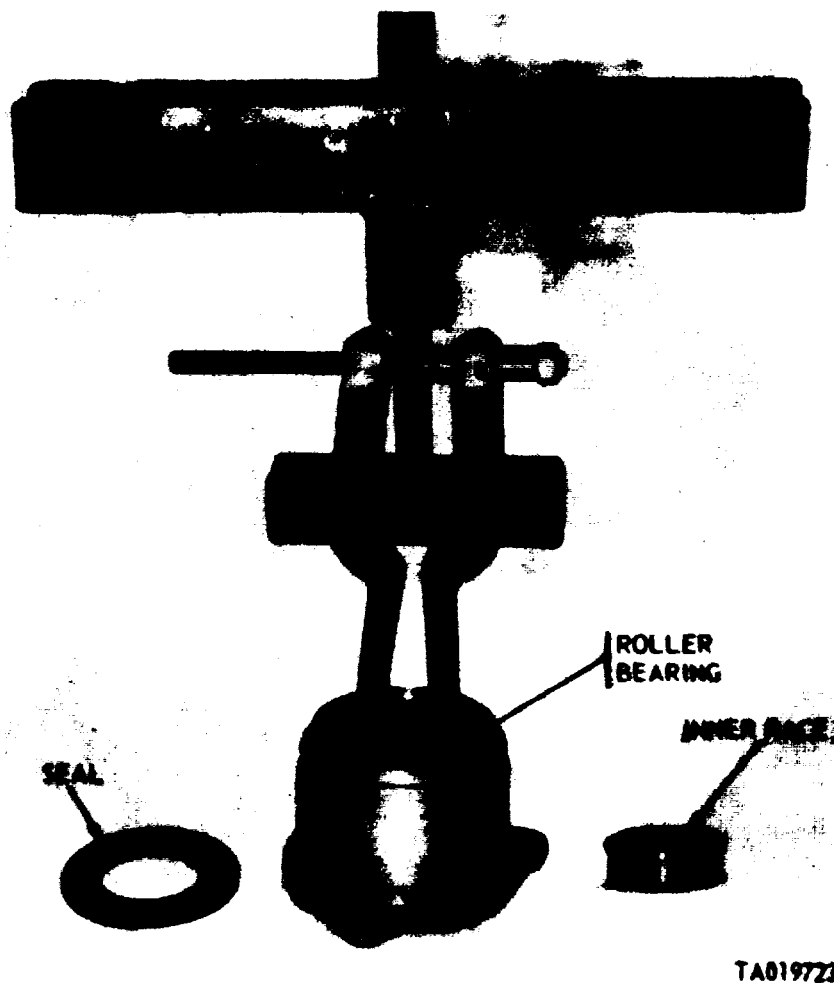

TA019723

Figure 3-30. Removal of MS19078-12 roller bearing from retainer using puller with Slide-hammer attachment from kit 5120-00-423-1596.

(12) With all components removed from the retainer, clean and examine the inner and outer surfaces for cracks, indication of wear, and distortion. Examine flange and mounting-hole threads as well as the counter-bore lip for damage which may interfere with assembly operations. Discard bearings, seal, and spacers.

b. Removal of Retainer Seal, Rear Roller Bearing and Spacers. Procedure for this removal is detailed below.

(1) Seal 5330-00-930-3108 has already been removed to show the identity of late type roller bearing MS19078-12 with puller attached for removal, in figure 3-30. Roller bearing inner race must be removed for installation of the puller.

(2) Obtain bearing puller and attaching components (fig. 3-30) from puller kit 5120-00-423-1596. As-

semble puller as illustrated in figure 3-30.

(3) Remove roller bearing inner race and inner spacer 11636362. Adjust bearing-remover jaws to permit passage through the bearing roller opening from the seal end of retainer. Turn bearing remover adjusting screw to spread jaws against the hearing rollers. While observing through the sealed bearing opening, adjust bearing remover jaws so that tips are engaging only the steel bearing rollers and not contacting the brass roller retainer. Tighten adjusting screw to maintain a secure engagement of jaws with bearing rollers.

(4) With puller attachments assembled to roller bearing as shown in figure 3-30, hold assembly with retainer down. Use the heavy horizontal split bar as a slide hammer and bump the roller bearing and outer race from the retainer.



Figure 3-31. Rear view of retainer with rear bearing and spacer (s) removal, showing location of locking 5365-00-99-4291 in place.



Figure 3-32. Snapping plier installed with offset tips to retainer wall for removal of snapping

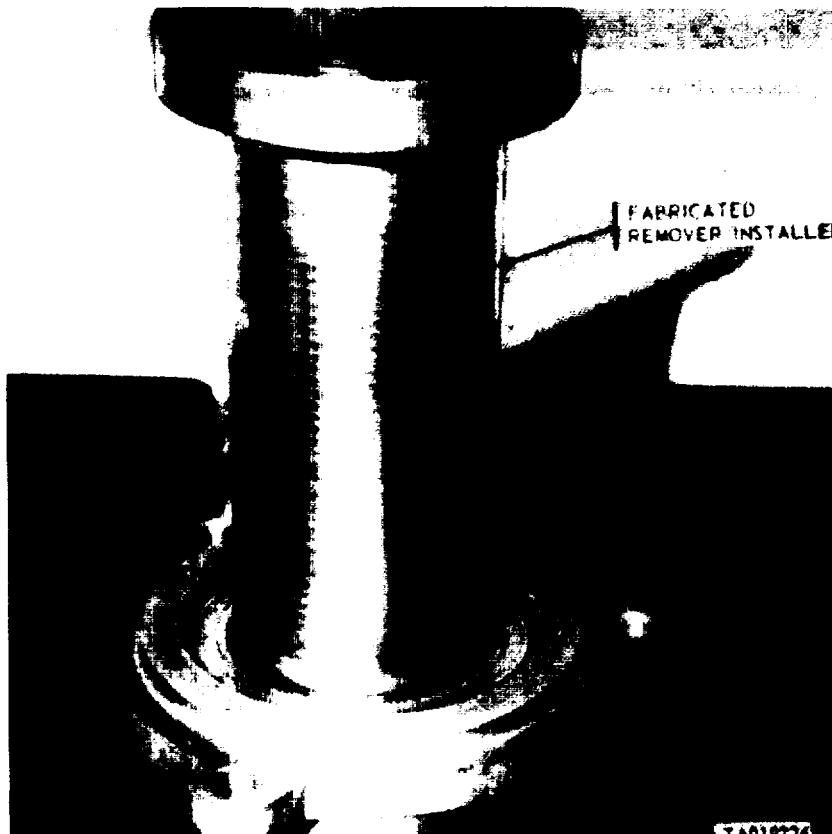

Figure 3-33. Removal of sealed bearing using fabricated remover/installer.



(5) Remove outer spacer. Clean retainer cavity. Locate sealed bearing retaining ring 5365-00-999-4291.

(6) Perform (6)a through (12) above, for removal of lockring and sealed bearing.

### 3-20. Cooling-Fan System Assembly - Assembly of Clutch to Rotor

a. Before Assembly. If used fan assembly is to be reused, it must be checked for cracks and gouges as follows:

(1) Wipe clean of dirt and oil.

(2) Apply dye penetrant liquid 6850-00-826-0981 to entire surface of fan rotor and to ribs, center section, and mounting legs of rotor.

(3) Wipe away excess dye penetrant.

(4) Examine for cracks.

(5) Cracked stators and rotors must be replaced.

(6) Rotors with gouges or breaks must also be replaced.

b. Prepare for Assembly.

(1) Place stator on hydraulic press bed with largest diameter (engine side) down. Place rotor on top of stator in normal order of assembly. The large circular rib at bottom of the rotor will mate with circular rib at top of the stator. While observing rotor blade tips at stator circular opening, hold stator in position and rotate rotor to check uniformity of blade position. If rotor wobbles during rotation, measure deviation of blade tip height. If deviation exceeds  $\frac{1}{8}$ -inch, replace

the stator and rotor before assembling the cooling-fan system.

(2) Thoroughly check the eight clutch-mounting screw holes for satisfactory thread condition. If any defective threads are evident, they must be repaired (use helicoil inserts) before the clutch is assembled to the rotor. The setscrew which secures the heat transfer element to the thermal sensor should be checked and torqued to 16-18 lb-in.

(3) Make sure that mating flange surfaces on the rotor and the clutch housing are perfectly clean before assembling the fan clutch to the rotor.

c. Assembly Procedure. Assemble as follows:

(1) Place square support on shop floor with 6-inch opening up (fig. 3-14).

(2) Place rotor on support with small front circular rib facing up.

(3) While observing location of clutch lockup device (C, fig. 3-22) on clutch housing, position clutch with shaft down, mating the lockup device with either of two large slots in the rotor mounting flange.

(4) Select the eight screws 5305-00-846-5703 (3/8-NC X 3 inches), removed at paragraph 3-18a (see note at paragraph 3-18a and as shown in figure 3-17). Also select eight flatwashers 5310-00-877-5972. Using one flatwasher per screw (not lockwasher) drop all eight screws into the clutch mounting holes as shown in figure 3-34.

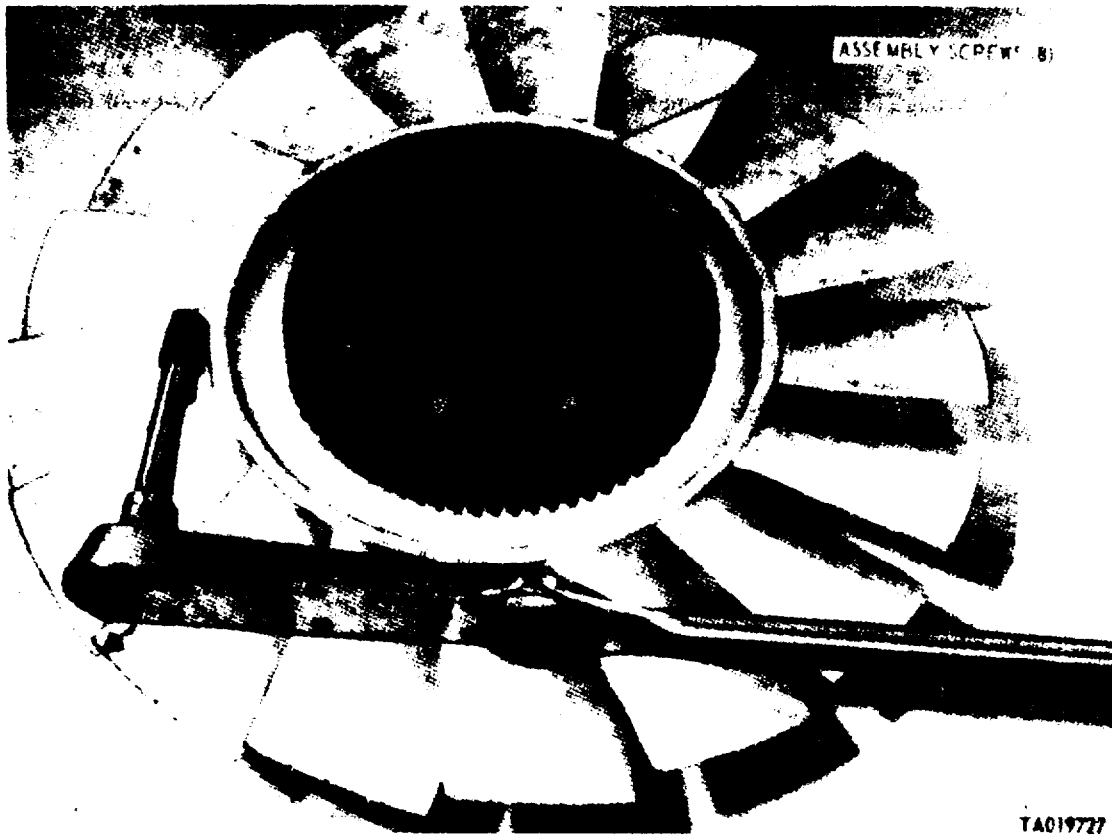

Figure 3-34. Installation of clutch to rotor.

(5) While supporting the clutch by hand, rotate the assembly until the eight screws engage with the threaded holes in rotor. Secure the eight screws until finger tight while pushing the clutch into the rotor opening.

(6) Using torque wrench 5120-00-247-2540 or 5120-00-640-6364 and following a criss-cross pattern, torque the eight mounting screws to 15 lb-ft. Repeat torque pattern to 25 lb-ft. Final torque, by same criss-cross pattern to 35 lb-ft.

**NOTE**

All torque values stated in this chapter are dry torque.

**3-21. Cooling-Fan System Assembly - Assembly of Sealed Bearing 11602332 to Retainer**

a. Place retainer on flat plate on bed of hydraulic press (fig. 3-35). Lubricate the inner walls of the retainer with grease MIL-G-81322.

b. Place new sealed bearing 11602332 hand tight, into the retainer cavity.

c. Place the fabricated remover installer between sealed bearing and press ram as shown in figure 3-35.

d. With retainer, bearing, and remover installer centered under press ram, apply pressing action until bearing is bottomed in retainer.

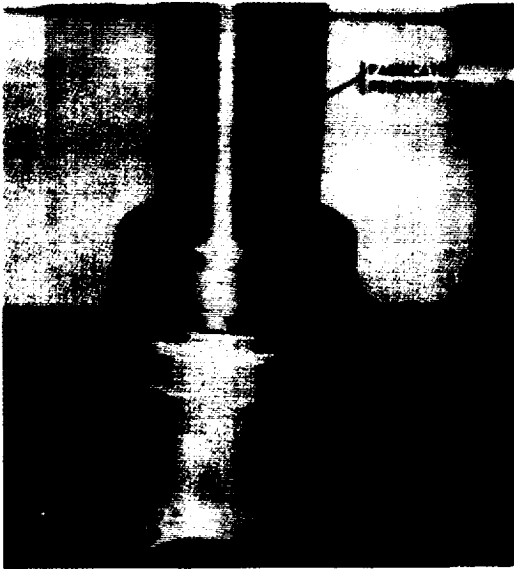

Figure 3-35. Installation of sealed bearing into retainer.

#### CAUTION

When sealed bearing nears the bottom of retainer cavity, the bearing will fall into the unbored area and applied pressure will vary momentarily. Pressing action must be resumed cautiously while the bearing enters the remainder of the bored area. Release hydraulic pressure and examine bearing position to make sure that the lockring groove is completely exposed.

### 3-22. Cooling-Fan System Assembly - Installation of Lockring 5340-00-999-4291 Into Retainer

- a. Place retainer (with sealed bearing installed) on the press bed or flat surface of work bench with bearing and flange down.
- b. Place lockring, with bevel side up, on solid flat surface. Attach HD lockring pliers 5120-00-293-0186 to the lockring, making sure that plier's offset tips are

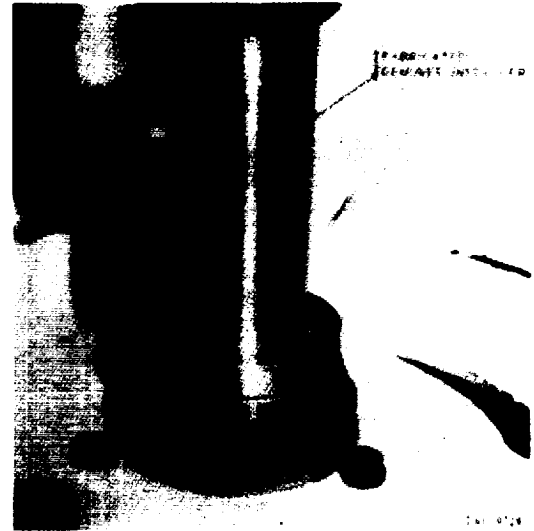

Figure 3-36. Installation of sealed bearing into retainer shown in stator.

completely engaged with locking holes and that tips are positioned facing outer edge of locking as shown in figure 3-37.

- c. Make sure locking pliers are properly engaged in holes of locking. Cover locking with protective cloth as a safety measure. Push pliers against the bench or hydraulic-press bed. Avoid finger contact with ratchet lever of the pliers. Press plier handles together and fully compress the locking.

- d. With protective cloth still covering the compressed locking, position pliers and locking directly above the retainer. Remove protective cloth. Carefully lower the locking into the retainer cavity locking groove. Do not tap locking from plier tips.

- e. Release plier ratchet by squeezing the handle lever. Remove locking pliers.

- f. If the locking is not fully seated, place a heavy screw driver against top of locking and gently bump the screw driver handle.

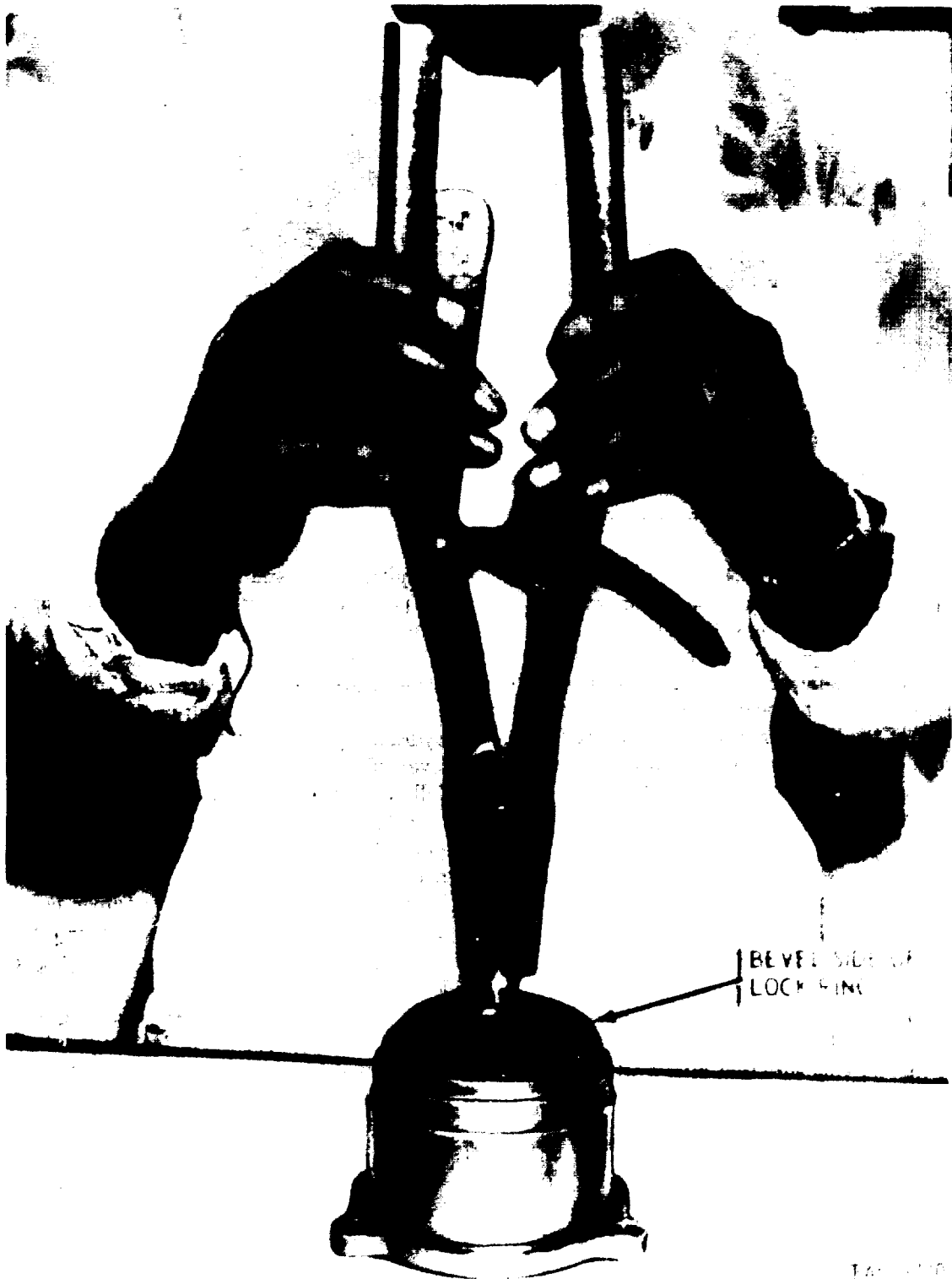

Figure 3-37. Installation of lockring (beveled side of lockring must be up).

g. Make sure the lockring is completely seated before proceeding with further assembly (fig. 3-31).

### 3-23. Cooling-Fan System Assembly, Installation of Retainer (with Sealed Bearing and Lockring Installed) on Fan Clutch (Installation of Sealed Bearing on Clutch Shaft)

(fig. 3-38)

a. Place square support, with 11-inch opening up, on hydraulic press bed. Engage lockup device, shown at D,

figure 3-38.

b. Place rotor and fan clutch (see para 3-20) on support with clutch housing centered in the 11-inch opening and clutch shaft facing the press ram. This position permits pressing stress to be transmitted from clutch shaft into clutch housing. Clean scratches, corrosion, or any foreign matter from clutch shaft to provide optimum pressing fit of shaft and inner bearing race. Coat the clutch shaft with light film of grease MIL-G-81322.

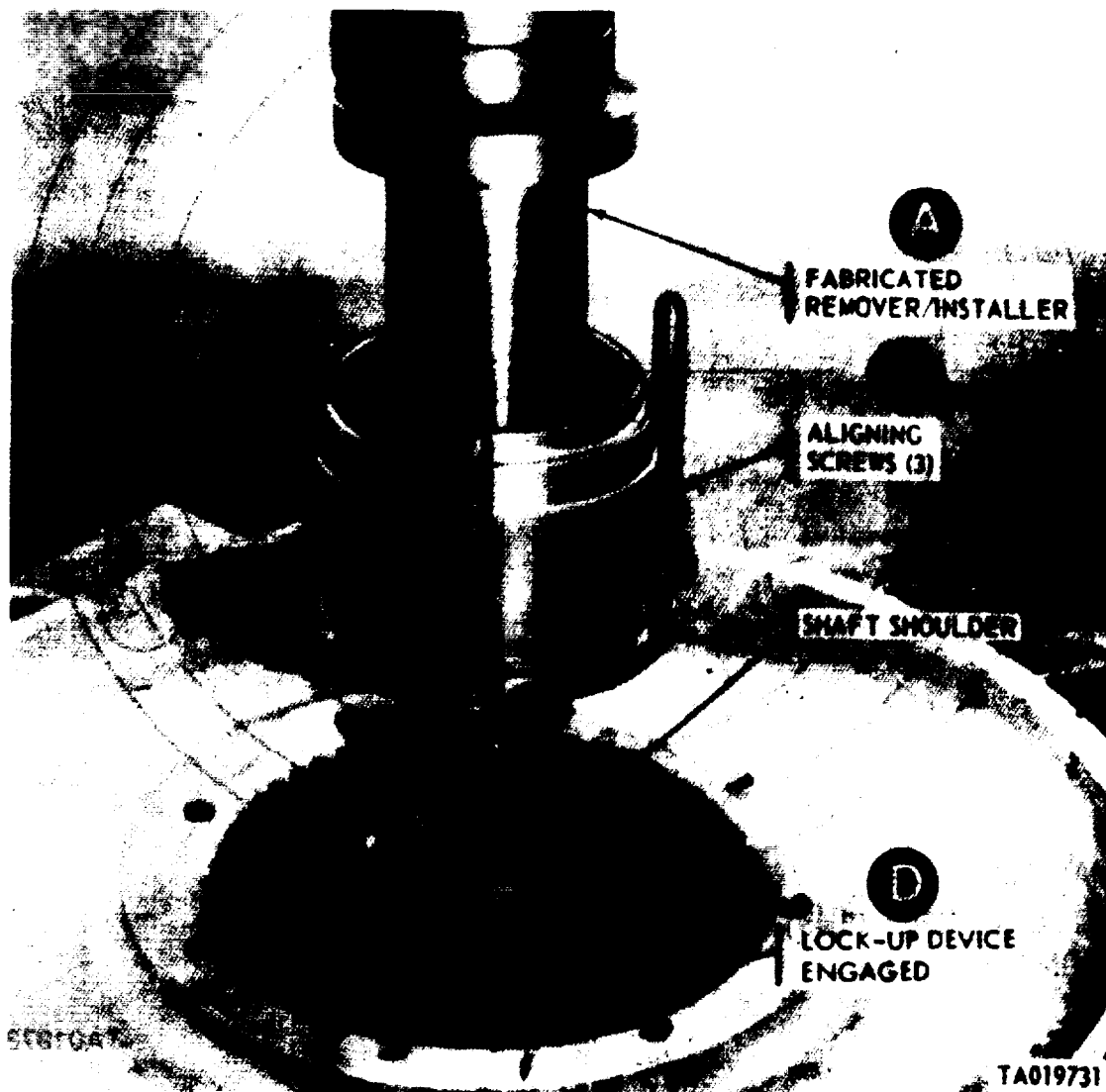

Figure 3-38. Installation of sealed bearing and retainer on clutch shaft

c. Place retainer (with sealed bearing and lockring installed) over end of clutch shaft. Place remover-installer (sleeve-end down) over clutch shaft as shown at A, figure 3-38.

d. Center assembly on press bed and with remover-

installer flange under press ram, apply pressing operation. Use slow, steady strokes as inner bearing race continues to move on the clutch shaft with a light effort.

**NOTE: ALL DIMENSIONS SHOWN ARE IN INCHES**

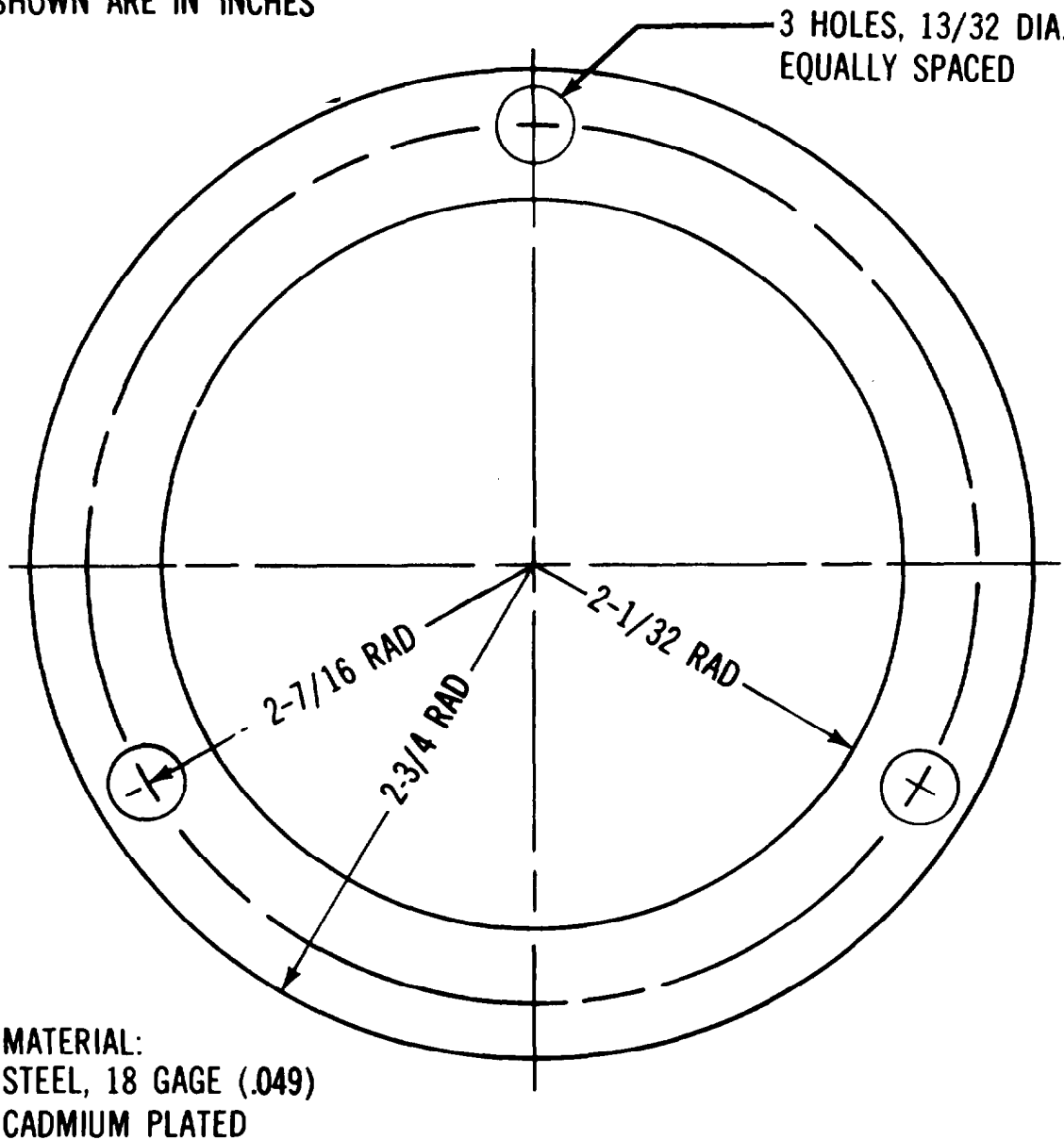

**TA019737**

Figure 3-39. Shim for fan

**CAUTION**

When bearing inner race contacts the shaft shoulder at C, figure 3-38, stop pressing. Do not overpress while making sure that bearing is bottomed. The distance  $2 + 1/64$  inches measured from end of the retainer to end of the clutch shaft will determine that the bearing is bottomed.

e. Install the three fabricated aligning screws as shown at B, figure 3-38 (see construction of, at C, fig. 3.16). These aligning screws will assist in installation of stator at figure 3.40. Install an 18 gage (.049) shim on flange of retainer. See [below].

f. The fan rotor inner flange can rub against the far. stator inner flange at low fan speeds. The two will not rub at high fan-speeds. To correct the rubbing at low

fan-speeds it is necessary to install an 18-gage shim between the mounting flange of the bearing retainer and fan stator. This keeps rotor and stator inner flanges from contacting each other. See figure 3-39 for construction of the shim.

### 3-24. Cooling-Fan System Assembly - Installation of Stator Using Three Fabricated Alining Screws



Figure 3-40. Installation of stator on retainer.

(2) Identify pressing zone for proper location of round spacer used in pressing operation. Place spacer on convex surface at center of stator. Center spacer with retainer mounting hole. Using marker (black crayon; etc.) scribe inside and outside circumference of spacer. Remove spacer and identify space between scribed circles as pressing zone (fig. 3-40).

(3) Position stator over clutch shaft and retainer with three guide (alining) screws engaging the three stator holes as shown in figure 3-40.

(4) Position spacer on top of stator at pressing zone. Place pressing plate on top of spacer. Center these assembled items under hydraulic-press ram. Operate press with slow, even strokes while observing movement of stator over the retainer.

#### CAUTION

Continue to press as long as movement is accomplished with little effort. Do not overpress

(fig. 3-40)

a With remover installer removed following installation of the retainer with sealed bearing at figure 3-38, install stator.

(1) Place stator on shop floor or hydraulic-press bed.

to achieve complete bottom position. Installation and torquing of three screws 5305-00-269-3243 (3/8-NF X 21/4 inches), will completely bottom the stator to retainer flange and shim. Observe the note in paragraph 3-18a concerning correct screw length and type of thread.

(5) Remove pressing plate and round spacer.

Remove the three alining screws. Install the three mounting screws, 5305-00-269-3243 (3/8 X 21/4 inches), and three flat washers, 5310-00-877-5972. Torque the screws to 25-30 lb-ft.

b. Prepare for next operation.

### 3-25. Cooling-Fan System Assembly-Preparation for Installation of Roller Bearing MS1 9078-12

a Position square support, with 11-inch opening up,

on hydraulic-press bed or shop floor (fig. 3-41). Position partly assembled cooling-fan system on support with the clutch housing centered in the 11-inch opening.

This permits a view of retainer and bearing cavity as shown in figure 3-42.



Figure 3-41. Installation of sealed bearing retainer (with stator installed) on clutch shaft

b. Recheck position of lockring for complete engagement of lockring groove as seen in figure 3-31. Install sleeve spacer 11636363 to bottom on lockring as shown at D, figure 3-42. Install sleeve spacer 11636362 over clutch shaft to bottom on sealed bearing inner race as shown in E, figure 3-42.

**NOTE**

Due to similarity in appearance, sleeve spacer 11636362 could become mixed with obsolete sleeve spacer 10956017 when unpackaged. Remove all obsolete sleeve spacers from parts bin or discard at time of disassembly from fan-clutch systems since they are no longer used.

**CAUTION**

Use of obsolete sleeve spacer 10956017 with roller bearing MS19078-12 will result in destruction of the bearing when the pulley nut is torqued to 110 lb-ft.

C. With sleeve spacers installed, pack roller bearing MS19078-12 and spacer cavity (1/2 to 3/4 full) with grease MIL-G-81322 as shown at A, figure 3-42.

**CAUTION**

Use only grease, aircraft, high temperature, MIL-G-81322 in hearing and spacer cavity.

**3-26. Cooling-Fan System Assembly - Installation of Roller Bearing MS19078-12 and Seal 5330-00-930-3108.**

a. Installation of bearing outer race. Refer to C, figure 3-42 and install as follows:

(1) Position square support, with 11-inch opening up, on hydraulic-press bed. Position partially assembled cooling-fan system with its clutch housing engaging the 11-inch opening of the support.

(2) Position outer bearing race with rollers, C, figure 3-42, over clutch shaft with outer race engaging the retainer opening as shown in figure 3-43.

**CAUTION**

Minimum pressing stress is achieved to prevent overloading of internal clutch components by installing the roller bearing in two operations. Removed inner race, B, figure 3-42 is pressed over clutch shaft separately.



(3) With outer race and rollers positioned and remover-installer centered under hydraulic-press ram (fig. 3-43) use slow, steady strokes on press handle to install outer race against sleeve spacer 11636363. Release hydraulic pressure and remove the remover-installer only. All cooling-fan system components are correctly positioned for inner race installation.

b. Installation of bearing inner race. Refer to B, figure 3-42, and install as follows:

(1) With roller bearing outer race bottomed against outer sleeve spacer, position inner race over clutch shaft (with thrust shoulder end of race facing UP).

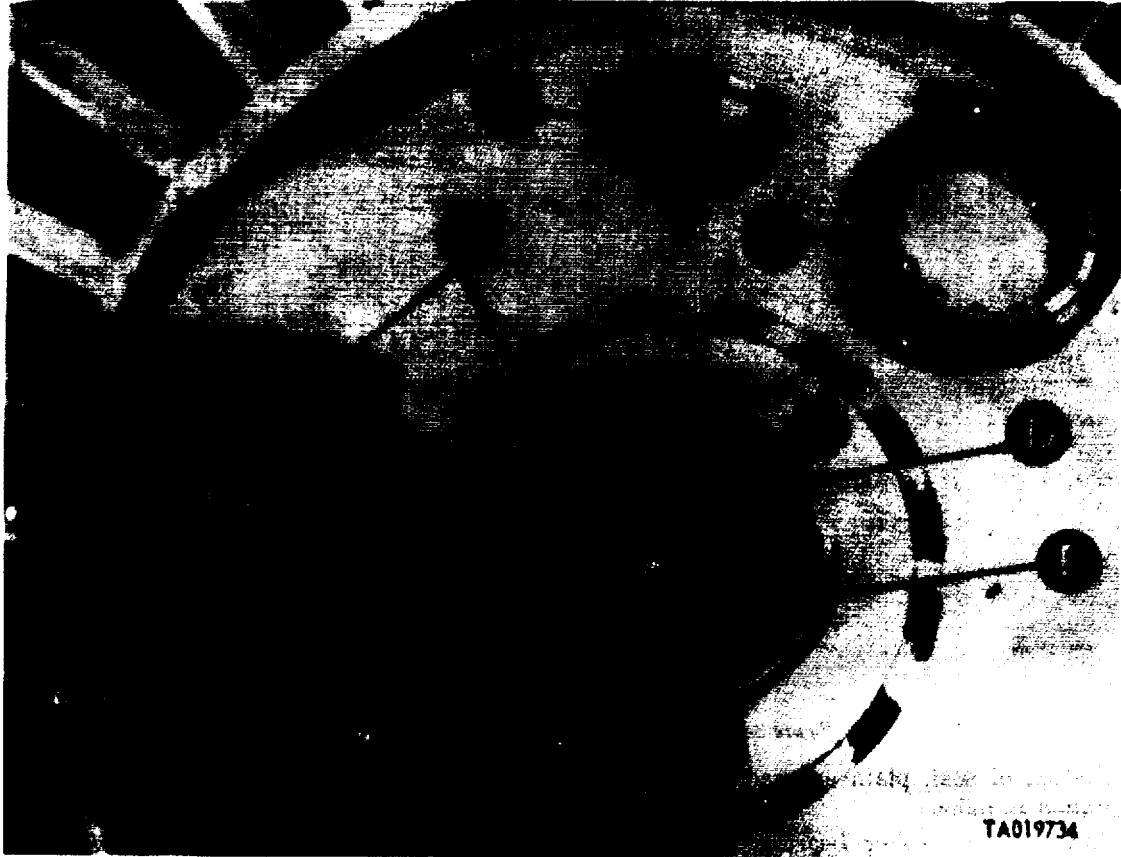

Figure 3-42. Installation of bearing spacers and lubrication of bearing cavity

(2) Position remover-installer, either end down, over clutch shaft. Center remover-installer under hydraulic-press ram and operate press handle with slow, steady strokes only until race shoulder contracts bearing rollers and/or until race bottoms against sleeve spacer 11636362.

**CAUTION**

Do not overpress. All components in the retainer cavity will be completely bottomed when the pulley retaining nut is torqued at 110 lb-ft.

(3) Release hydraulic pressure and remove the remover-installer only.

(4) Examine drive key and remove all burr.

(5) Install drive key in keyway of clutch shaft. Using a brass drift or plastic mallet, tap the key unit until it is completely bottomed in the keyway with its straight edge parallel to the clutch shaft.

(6) Slide the pulley spacer down over the clutch shaft until it bottoms against the inner race of the two-piece roller bearing and engages the key in the clutch shaft.



Figure 3-43. Installation of new MS19078-12 roller bearing.

c. Installation of seal, plain encased. This grease seal is installed as follows:

(1) With complete roller bearing MS19078-12, key, and pulley spacer installed, position a new seal 5330-00-930-3108 over clutch shaft.

(2) Position the seal with the lip facing away from the bearing and slip it down the clutch shaft until the lip contacts the pulley spacer. Ease the seal lip onto the pulley spacer and slide it down until the outer diameter of the seal engages evenly in the retainer bore.

(3) Using spare sleeve spacer 11636363 to push seal into retainer, slip the spacer over the clutch shaft down onto the seal. Align the spacer with the edge of

the seal. Position the remover-installer over the clutch shaft with flange-end down, see figure 3-44. Apply even pressure to sleeve spacer and sleeve. Press cautiously until rear face of seal is flush with end of retainer. Remove the remover-installer and spare sleeve-spacer.

**CAUTION**

Do not press rear face of seal beyond edge of the retainer in order to prevent seal from rubbing against inner race of roller bearing MS19078-12 (see fig. 3-44).

d. Remove partially disassembled fan clutch system and square support from the hydraulic-press bed.



Figure 3-44. Installation of drive-bearing grease seal

### 3-27. Cooling-Fan System - Installation of Drive Pulley

a Preparation for Installation of Multipiece Pulley. Refer to figure 3-45 for items required to have prepared prior to installation of the multipiece pulley. The six items portrayed in figure 3-45 are described below.

(1) Keyway fan drive washer (spacer) 5310-00-502-5836 (this spacer is already installed ahead of the flanged bushing into the grease seal and is thereby hidden from view).

(2) Bushing 2930-00-451-8101 is installed on clutch shaft with flange next to the spacer as shown. The tapered hub of the bushing is facing threads of the clutch shaft.

(3) Pulley 3020-00-472-4229 is installed with the tapered center opening over the mating tapered hub of the bushing with mounting-screw hole counter bores also facing the thread end of the clutch shaft.

(4) Pulley screws (mounting) four each 5305-00-456-6761 are self-locking and are installed without lockwashers before positioning the key washer.

(5) Key washer 5310-00-205-8249 is the standard key washer also used with cast pulleys. The key washer is installed with the single inner tab down and outer locking tabs facing up to match the bevel edge of the round nut.

(6) Round nut (plain) 5310-0-225-8327 is installed with bevel side down.

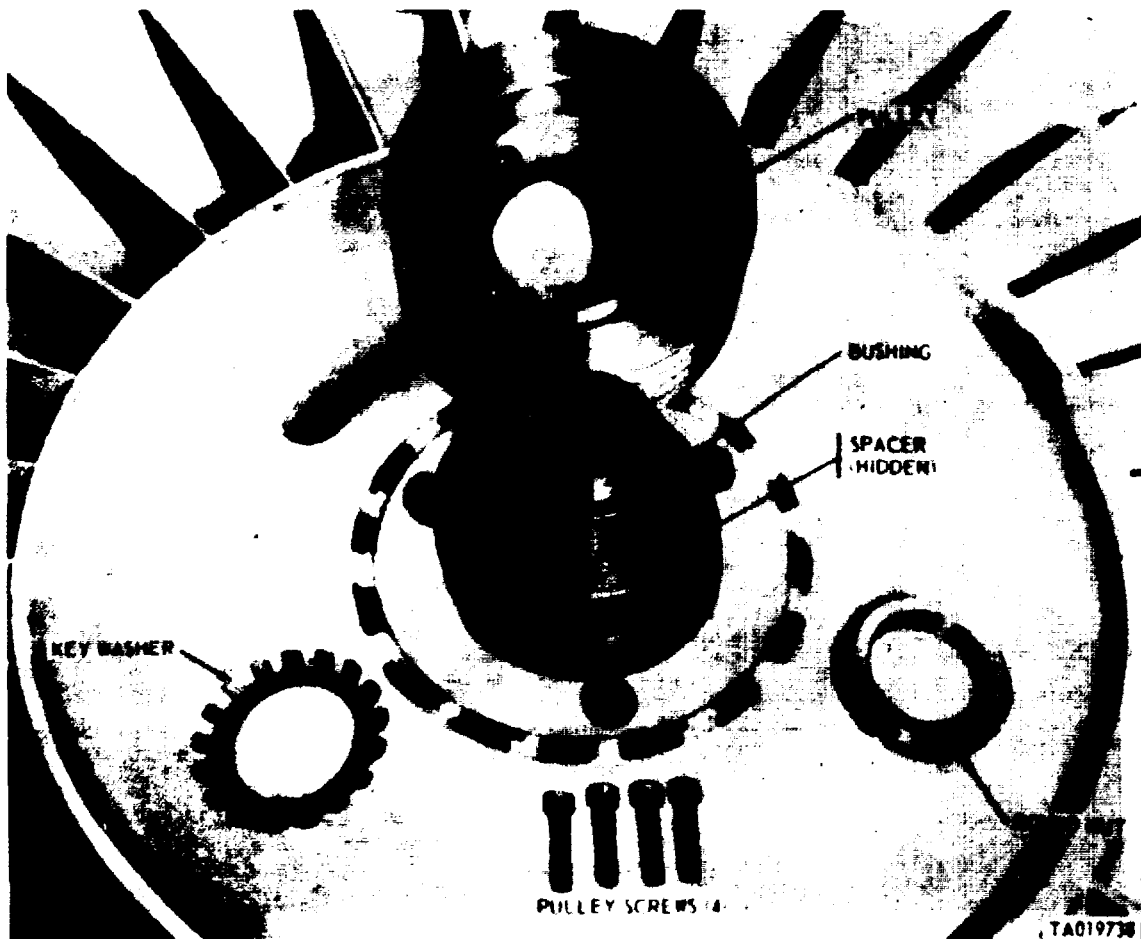

Figure 3-45. Multipiece pulley (unassembled).

b. Assembly of the Multipiece Pulley. Durability in operation of this pulley through proper retention to the clutch shaft depends entirely upon proper installation. The following sequence in application of mechanical engagements is required.

(1) Install the split bushing (flange-end down), a(2) above, over the clutch shaft and drive key until bottomed against spacer. Apply thin film of oil to tapered surface of bushing hub.

**NOTE**

Do not press pulley bushing onto the clutch shaft. If the bushing does not slip freely onto the clutch shaft, wedge it open slightly in the slot of its flange, and slide it down the clutch shaft to bottom against the pulley spacer. Remove wedge. If slit in the bushing is burred

during assembly, remove the burr.

(2) Apply thin film of oil to tapered center opening of pulley, a(3) above. Position pulley (with four screw-hole counter-bores facing up) over bushing tapered hub and aline four counterbored holes with four threaded-holes in hub flange.

**CAUTION**

Do not tap pulley.

(3) Install four screws (dry) in bushing flange threads, finger-tight only.

(4) Position key washer over clutch-shaft threads with single inner tab engaged with milled groove in shaft threads.

(5) Position round nut on shaft threads and tighten by hand. The assembled pulley should now appear as shown in figure 3-46.



Figure 3-46. Multipiece pulley (assembled, not torqued).

c. Preparation for Torquing the Multipiece Pulley.

Tools required to perform the complete torquing operation are shown in figure 3-47. These six tools are described and identified as follows:

- A-Adjustable wrench 5120-00-449-8084. Used to tighten the round nut to snug fit as well as a backup holding tool during final torquing.
- B-Pipe extension. Used to extend length of wrench A during torquing.
- C-Impact socket 5130-00-449-7698 with extension bit (Allen) 5130-00-049-7913. Used to apply lb-in torque to the four pulley-mounting

screws.

- D-Torque wrench lb-in 5120-00-247-2536. Used with impact socket and extension bit (C) to apply torque to the four pulley-mounting screws.
- E-Spanner wrench (special tool) 5120-00-907-0698. Used with heavy-duty torque wrench (F) to apply final torque to pulley round-nut.
- F-Torque wrench (3/4inch drive) 5120-00-221-7983, and socket (7/8-inch opening, 3/4-inch drive). Used with spanner wrench (E) to apply 110 lb-ft. final torque to pulley roundnut.



Figure 3-47. Multi-piece pulley prepared for torquing].

d. Multi-piece Pulley Torquing Procedure. Tools required for torquing procedure are shown in figure 3-47. Torquing procedure of multi-piece pulley is as follows:

(1) Position spanner wrench E in hollow clutch shaft to engage with protruding pulley drive-key as well as to engage the four lugs of the spanner with the four slots in the round nut.

(2) Position wrench A on large hexagon of spanner wrench E as shown. Turn large hexagon clockwise until retaining nut is snug and fully engaged with threads of clutch shaft.

(3) Install pipe extension B on wrench A. Two men are required to hold wrench A and extension B in stationary position while the round nut is torqued.

(4) Place torque wrench (S-inch socket) F on top of small hexagon of spanner wrench E as shown.

(5) Pull counterclockwise on torque wrench F to 110 lb-ft of torque to position fan drive and pulley components. Loosen nut and retighten it to 5 lb-ft torque to hold fan drive and pulley components in place while tightening the tapered bore pulley on the tapered bushing.

(6) Use extension bit and socket at C, figure 3-47, with torque wrench D to torque the four pulley screws in a five-step criss-cross pattern as follows:

- (a) Torque to 10 lb-in.
- (b) Torque to 25 lb-in.

(c) Torque to 50 lb-in.

(d) Torque to 75 lb-in.

(e) Torque to 100 lb-in.

(7) Betighten the nut by pulling counterclockwise on the torque wrench to 110 lb-ft. Observe the key washer for alignment of the locking tab. If one tab of the key washer is aligned with one slot of the round nut, bend the tab into the slot of the nut. If no tab is aligned, select a tab nearest to becoming aligned when the nut is turned clockwise. Apply increased torque to align the tab with the slot in the nut, and bend the tab into the slot.

(8) Measure distance from back of stator to forward edge of pulley. Distance should be  $35/8 \pm 1/16$  inches to assure belt alignment.

### 3-28. Functional Check - Perform Functional Check

Check is made as described below.

a. The setscrew which secures the heat transfer element (fig. 3-17) to the thermal sensor of the fan clutch should be checked and torqued to 16-18 lb-in,

b. Measure end play of fan rotor. Using depth micrometer, measure distance from face to heat transfer unit to flat center surface on face of clutch. Push in the rotor and take measurement, then pull out the rotor and take measurement. The difference in measurements is the end play. If end play is less than

.060 inch or greater than .100 inch, fan clutch must be replaced.

c. Measure clearance between tips of rotor blades and shroud of stator, using a feeler gage. If clearance exceeds .100 inch, or rotor blade touches stator shroud, replace the fan assembly.

**Section V. REPAIR OF ENGINE AND HULL ELECTRICAL SYSTEMS**

**3-29. General**

*a. Scope.*

(1) This section illustrates the engine and hull electrical circuit diagram (fig. 3-48 and 3-49), lists and identifies electrical circuit numbers, table 3-5, and illustrates and describes procedures for the removal and installation of engine and hull electrical systems harnesses.

(2) Disassembly and assembly procedures are also illustrated for the generator drive.

(3) Tabulated repair data is provided for the generator drive.

*b. Detailed References*

Refer to TM 9-2350-230-20-1 for the removal and installation of the following electrical components:

- Generator
- Generator drive
- Generator belt tensioner
- Voltage regulator
- Starter
- Disconnect to starter wiring harness
- Driver's switch and indicator panels
- Master relay
- Starter relay
- Bilge pump relay
- Receptacles
- Transmitters and switches
- Battery cable
- Generator regulator-to-generator harness
- Batteries
- Blower motors
- Blower motor relay
- Blower motor circuit breaker
- Engine disconnect to instrument wiring harness
- Engine disconnect to starter wiring harness
- Engine disconnect to master relay wiring harness

**3-30. Removal and Installation of Engine Electrical System Wiring Harness**

*a. Removal and Installation* Harnesses illustrated and described in this section are listed in table 3-4.

*b. Repair.* Refer to TM 9-2350-230-20-1 for repair of harnesses and harness components.

**NOTE**

This completes the disassembly/assembly of the cooling-fan system. Repair and calibration of the cooling-fan drive clutch will be done at depot overhaul facilities.

*Table 3-4. Engine Electrical System Harness*

Wiring harness name	Figure reference
Hull Rear Wiring Harness .....	3-53

*Table 3-5. Hull Electrical Circuit Number Reference Chart*

Circuit number	Circuit
10 .....	Battery-ground
11 .....	Battery - master relay
11T .....	Master relay-to-turret power relay
12 .....	Master relay - master switch
12B .....	Battery - master switch
12C .....	Starter switch-to-rectifier
12L .....	Master switch warning light
323C .....	Odometer switch - engine indicator panel
422 .....	Light switch - L.R/B.O. headlight selector switch
422A .....	L.R/B.O. switch - B.O. drive headlight
423 .....	Light switch - spotlight switch
424 .....	Light switch - headlight dimmer switch - service drive
425 .....	Headlight dimmer switch - high beam service headlight
426 .....	Headlight dimmer switch - low beam service headlight
427 .....	I.R/B.O. high beam headlight switch - headlight
427L .....	I.R. warning light
428 .....	I.R./B.O. low beam headlight switch-headlight dimmer switch and LR/B.O. low beam headlight
423L .....	I.R. warning light
423 .....	Headlight dimmer switch - engine indicator panel-high beam indicator light
432 .....	Circuit breaker-dome light
422A .....	Light switch - panel light - engine indicator panel - driver's switch panel
521 .....	Windshield wiper switch - windshield wiper
521B .....	Circuit breaker - windshield wiper
521L .....	Windshield wiper warning light
560 .....	Personnel heater - ground
561 .....	Battery - heater control box (personnel and winterization kit)
562 .....	Heater control-coil and flame detector switch
563 .....	Heater control - coolant thermostat and solenoid valve
563A .....	Heater control - fuel pump
564 .....	Heater control - blower motor
565 .....	Heater control - flame detector switch
581 .....	Starter relay-to-blower motor relay

Table 3-6. Hull Electrical Circuit Number Reference Chart - Continued

Circuit number	Circuit
581A . . . . .	Starter relay-to-blower motor relay
720 . . . . .	Fire extinguisher solenoid-to-ground
721 . . . . .	Bilge pump switch - bilage pump relay
721B . . . . .	Rear bilge pump relay
721BL . . . . .	Front bilge pump indicator light
721L . . . . .	Front bilge pump indicator light
722 . . . . .	Power circuit -bilge pump relay (rear bilge pump)

Table 3-5. Hull Electrical Circuit Number Reference Chart - Continued

Circuit number	Circuit
722A. . . . .	Bilge pump relay-circuit breaker (rear bilage pumps)
722B . . . . .	Circuit breaker - right rear bilge pump
723 . . . . .	Power circuit - bilge pump relay (front bilge pump)
723A. . . . .	Bilge pump relay-circuit breaker (front bilage pump)
723B . . . . .	Circuit breaker - front bilage pump
725 . . . . .	Fire extinguisher solenoid-to-slipring
726. . . . .	Turret power relay-to-slipring



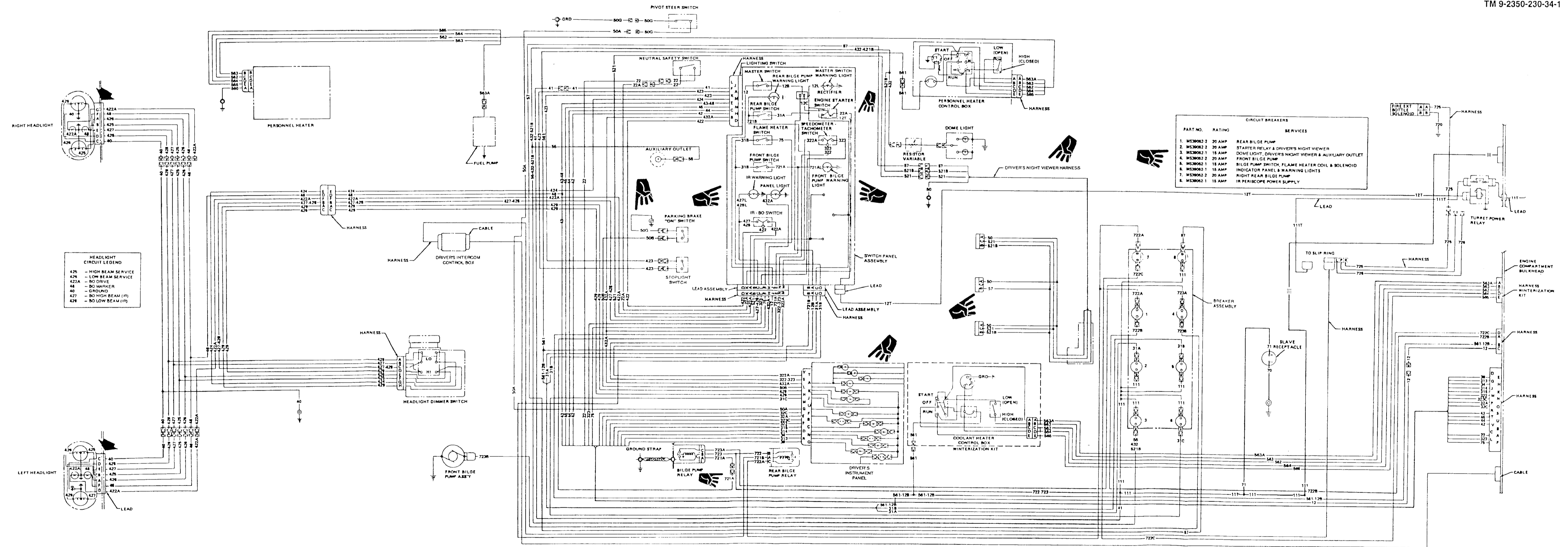

Figure 3-18. Hull electrical circuit diagram (sheet 1 of 2).

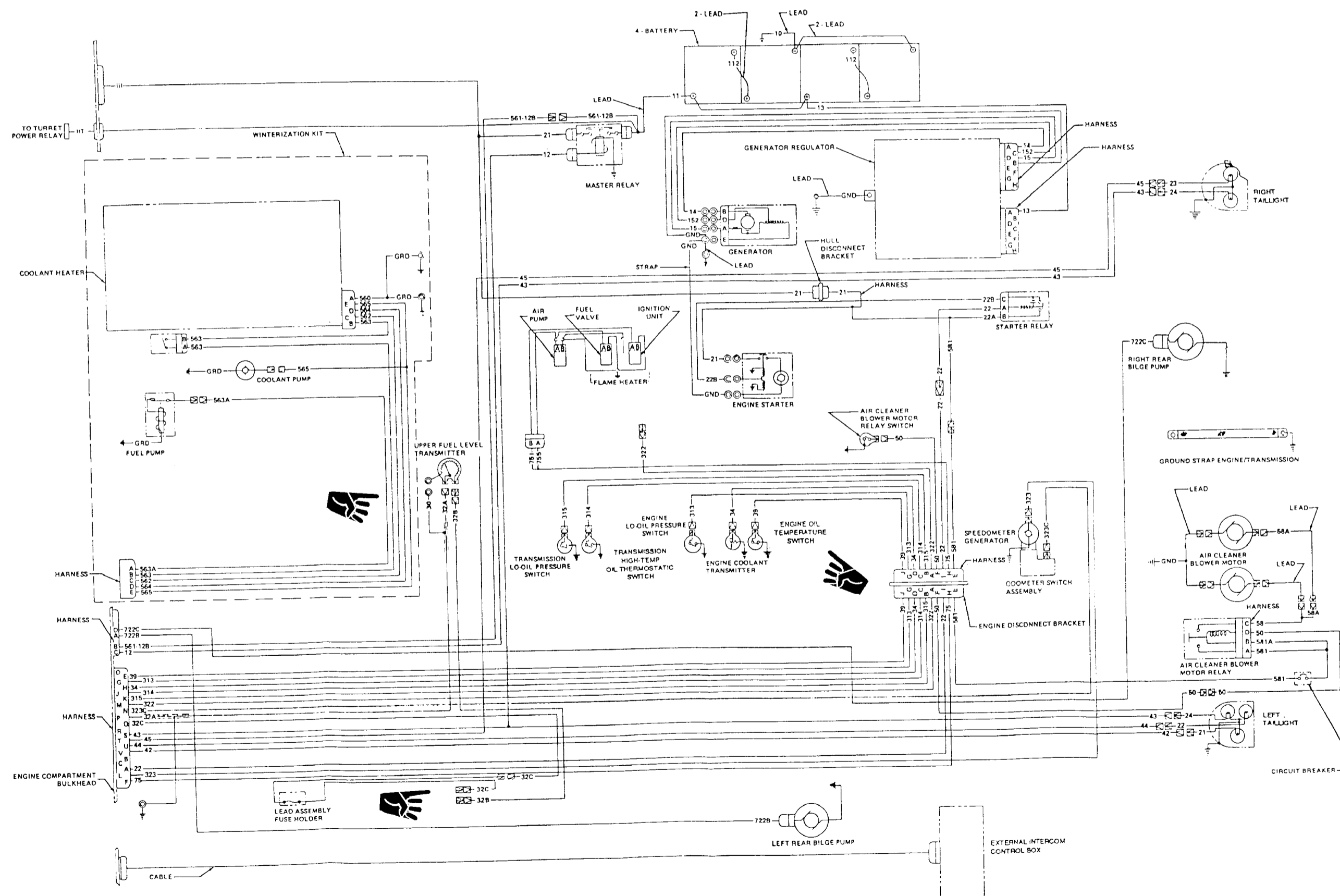
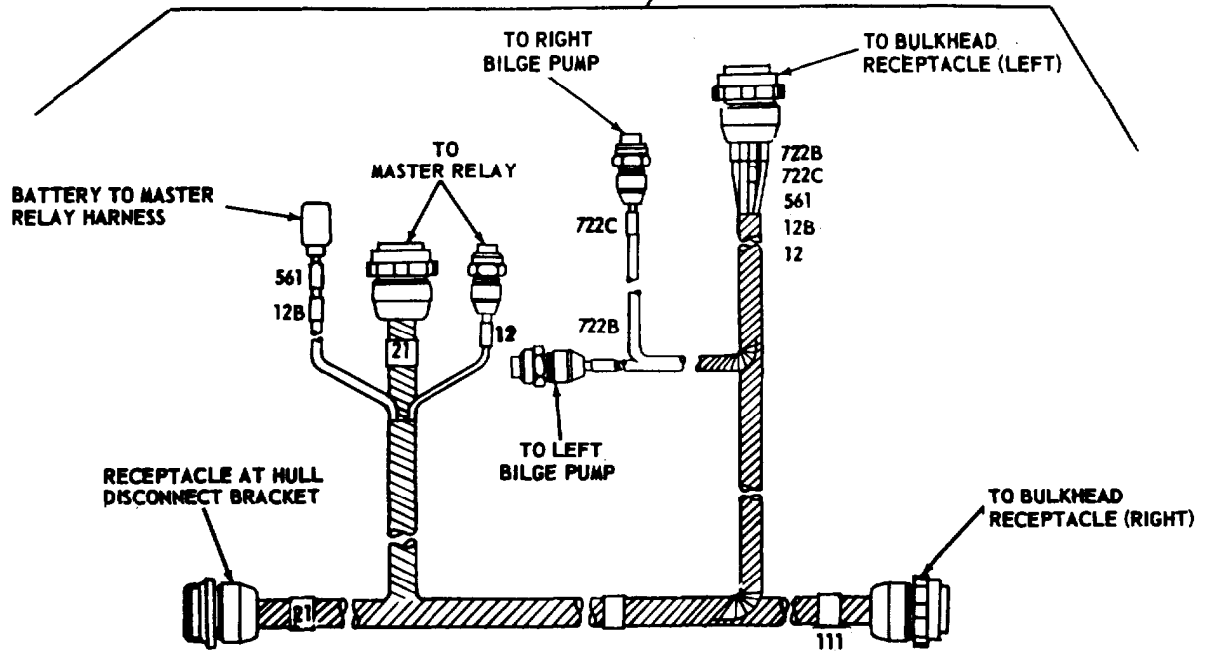
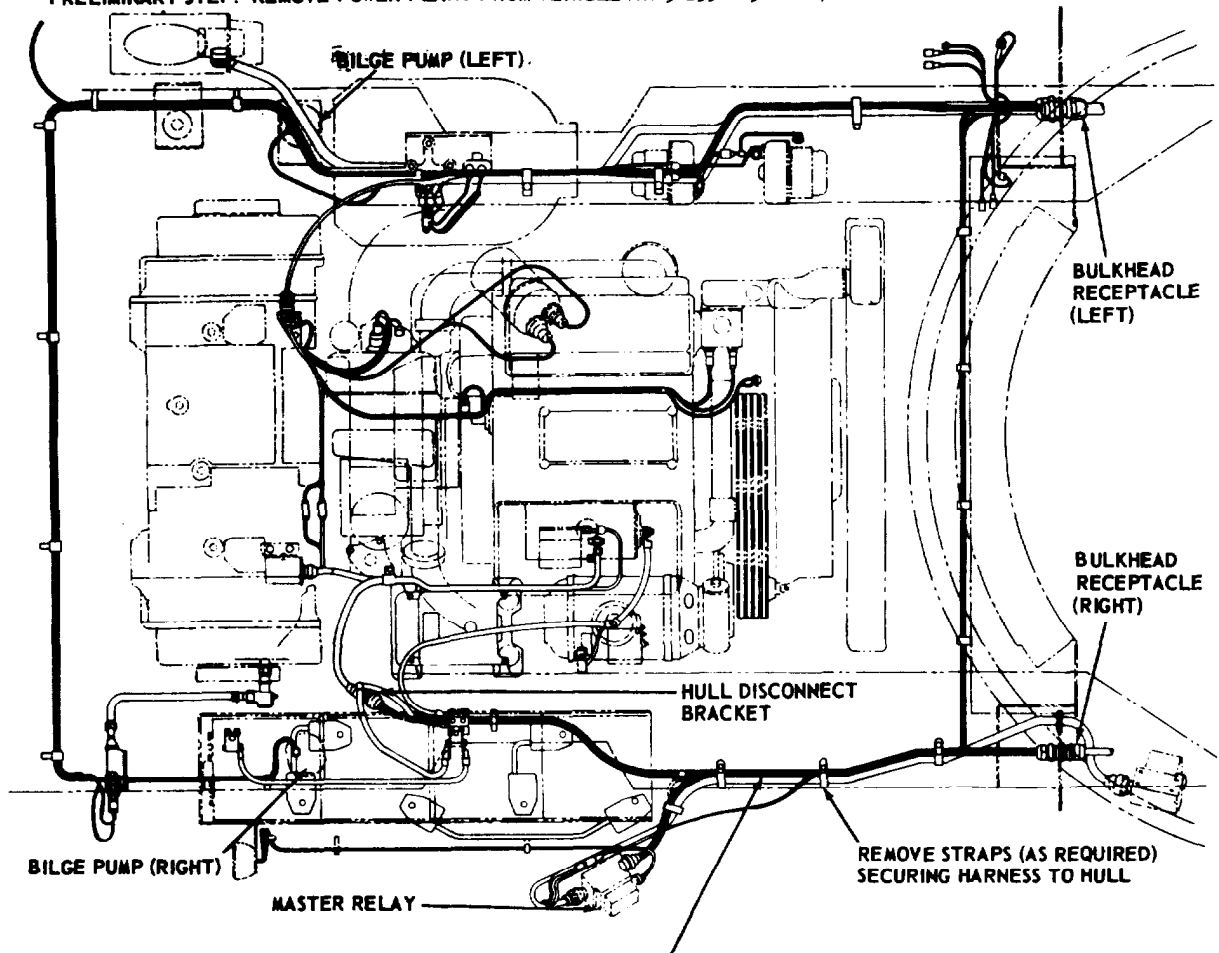

Figure 3-49. Hull electrical circuit diagram (sheet 2 of 2).



PRELIMINARY STEP. REMOVE POWER PLANT FROM VEHICLE (TM 9-2350-230-20-1)



TA 014792

Figure 3-50. Removal/installation-engine disconnect-to-master relay wiring harness

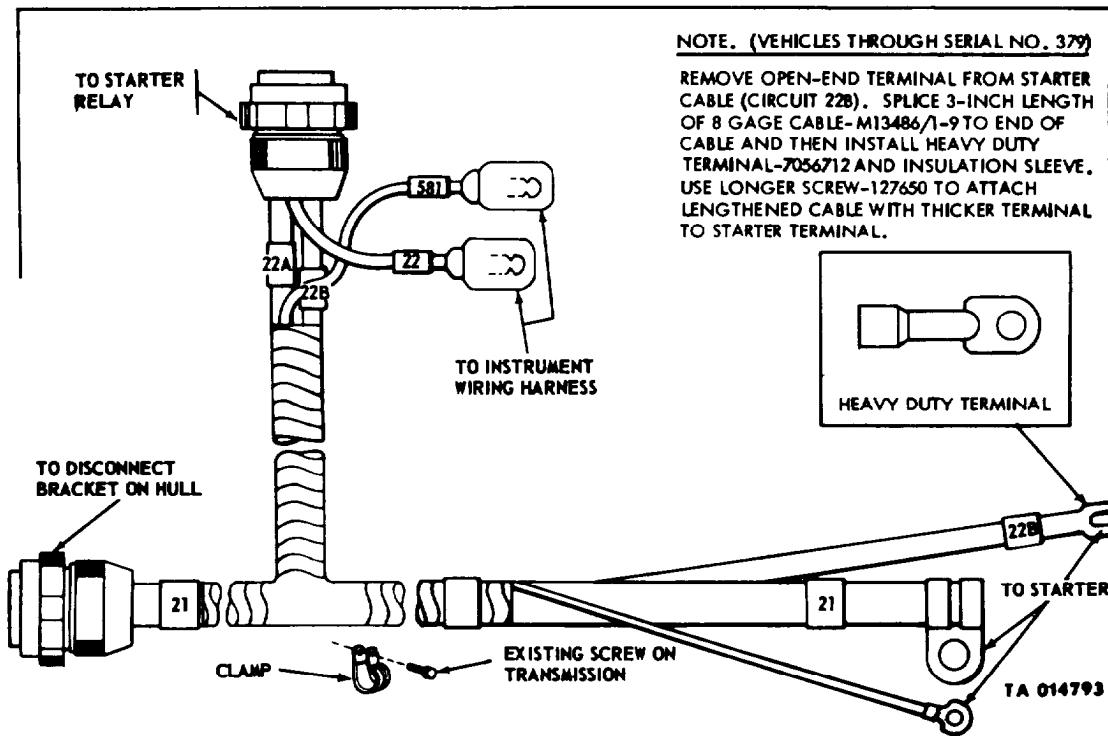
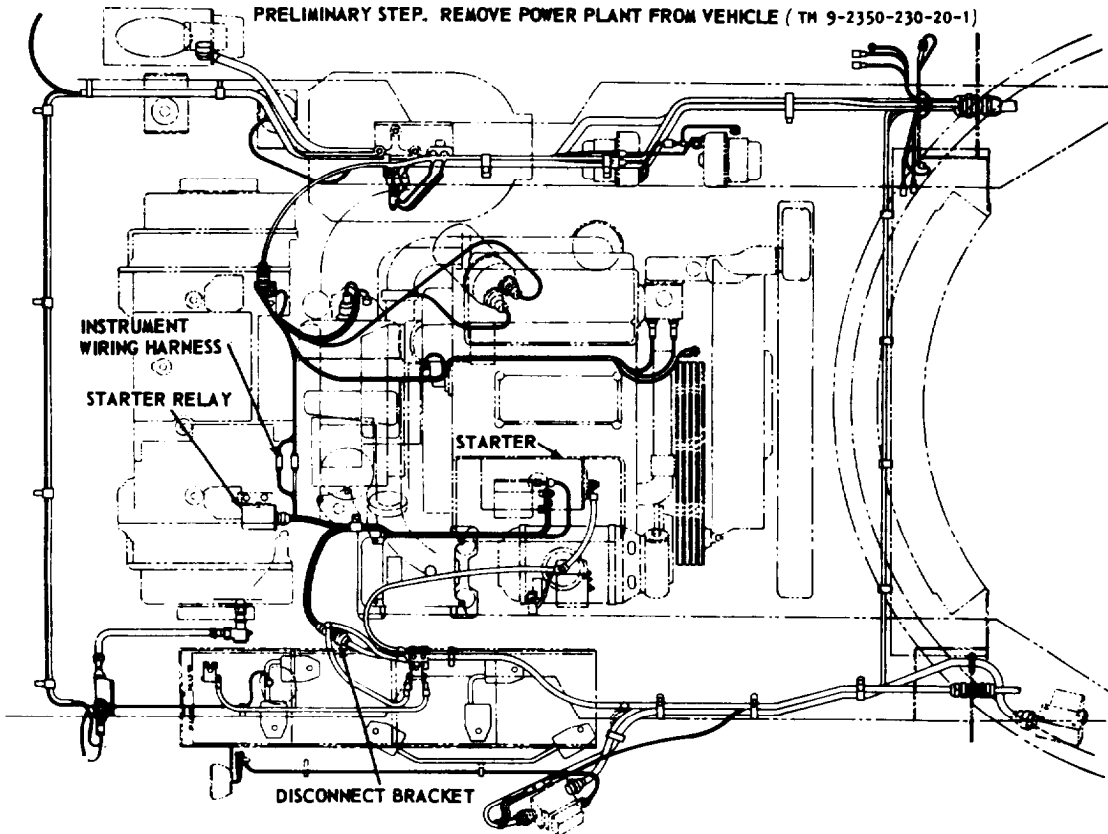

Figure 3-51. Removal/installation-engine disconnect-to starter wiring harness



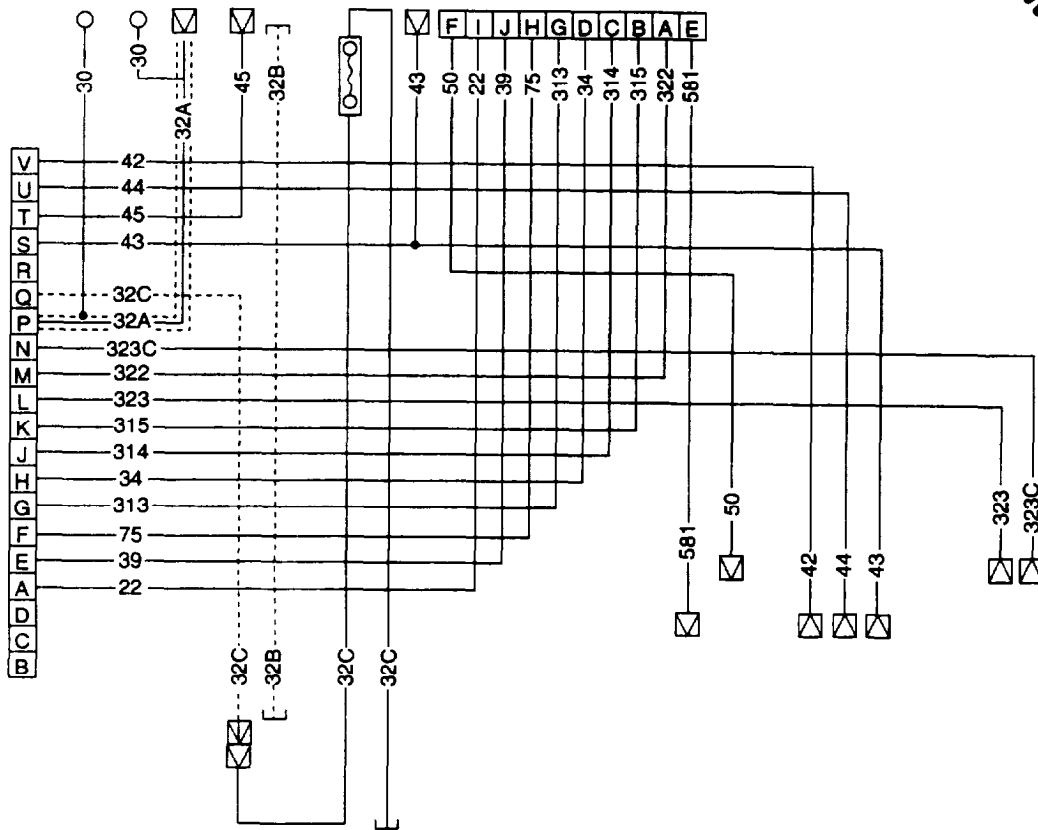

Figure 3-53.1. Removal/installation - hull rear wiring harness (2 of 2).

**3-31. Removal and Installation of Hull Electrical System Wiring Harness**

*a. Removal and Installation.* Harnesses illustrated and described in this section are listed in table 3-6.

*b. Repair.* Refer to TM 9-2350-230-20-1 for repair of harness and harness components.

*Table 3-6. Hull Electrical System Harness*

Wiring harness name	Figure reference
Slip Ring-to-Crew Compartment Fire Extinguisher .....	3-54
Hull Front Power .....	3-55 and 3-56
Forward Ground Intercom Cable.....	3-60
Ground Intercom Box-to-Bulkhead Cable .....	3-61
Driver's Intercom-to-Contact Ring Cable .....	3-62

**3-32. Repair of Generator Drive**

*a Disassembly and Assembly.* Refer to figures 3-64 through 3-66.

*b. Repair.* Refer to figure 3-67 and table 3-7.

**3-33. Deleted**

**3-34. Deleted**



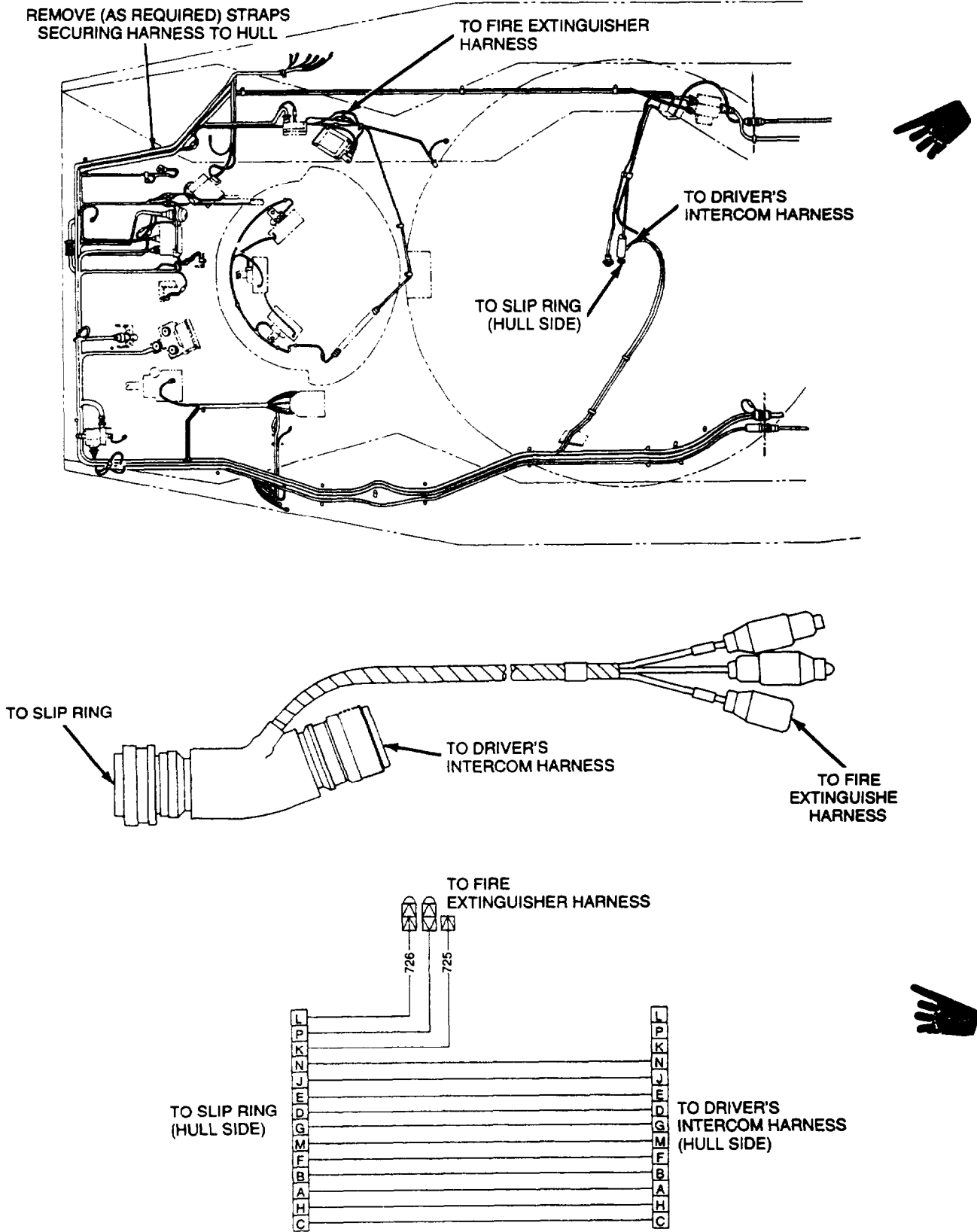

Figure 3-54. Removal/installation -slip ring-to-crew compartment fire extinguisher wiring harness.

PRELIMINARY STEP. REMOVE AIR INTAKE GRILLE (TM 9-2350-230-20-1).

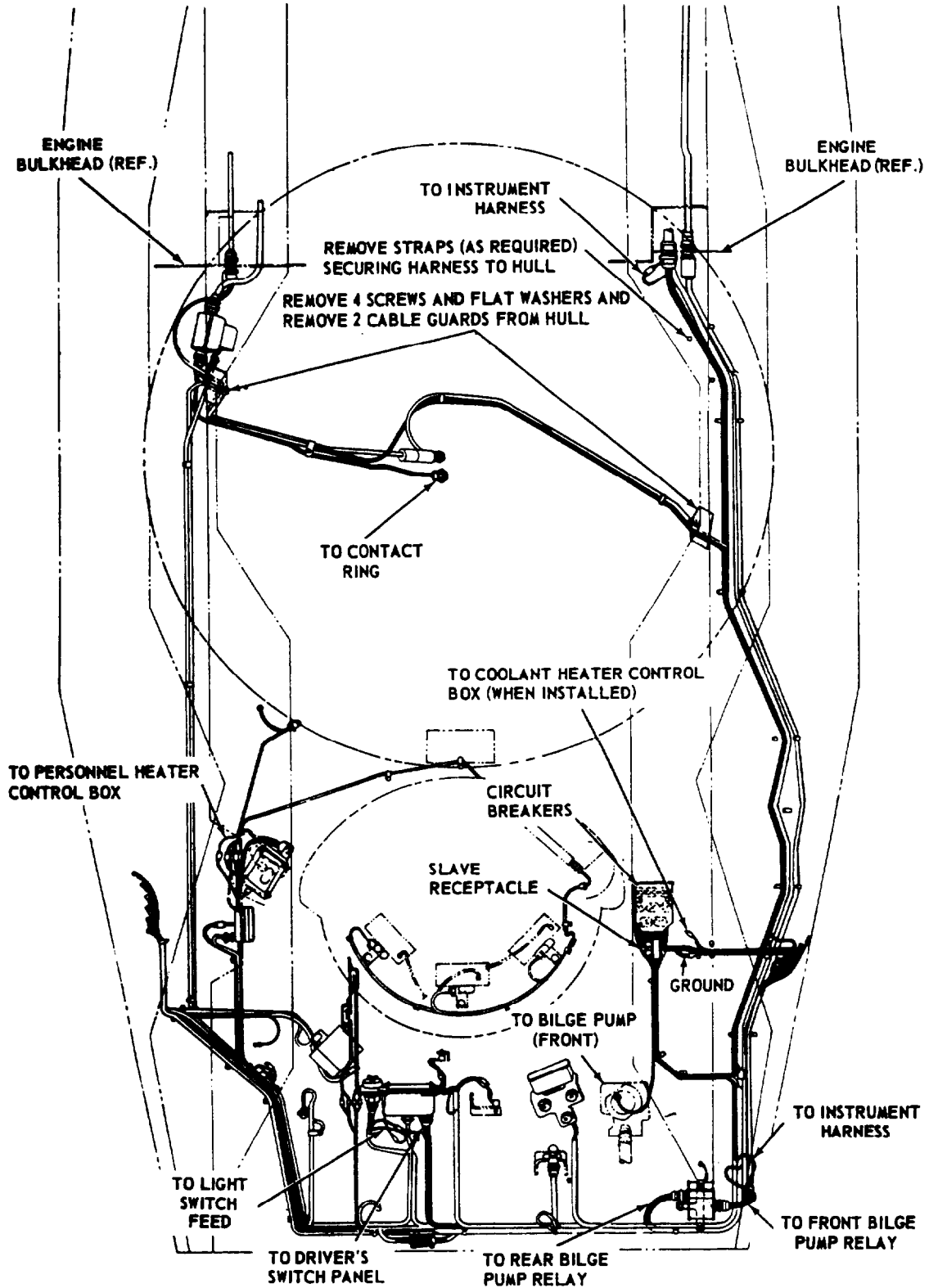

Figure 3-55. Removal/installation — hull front power wiring harness (1 of 3).

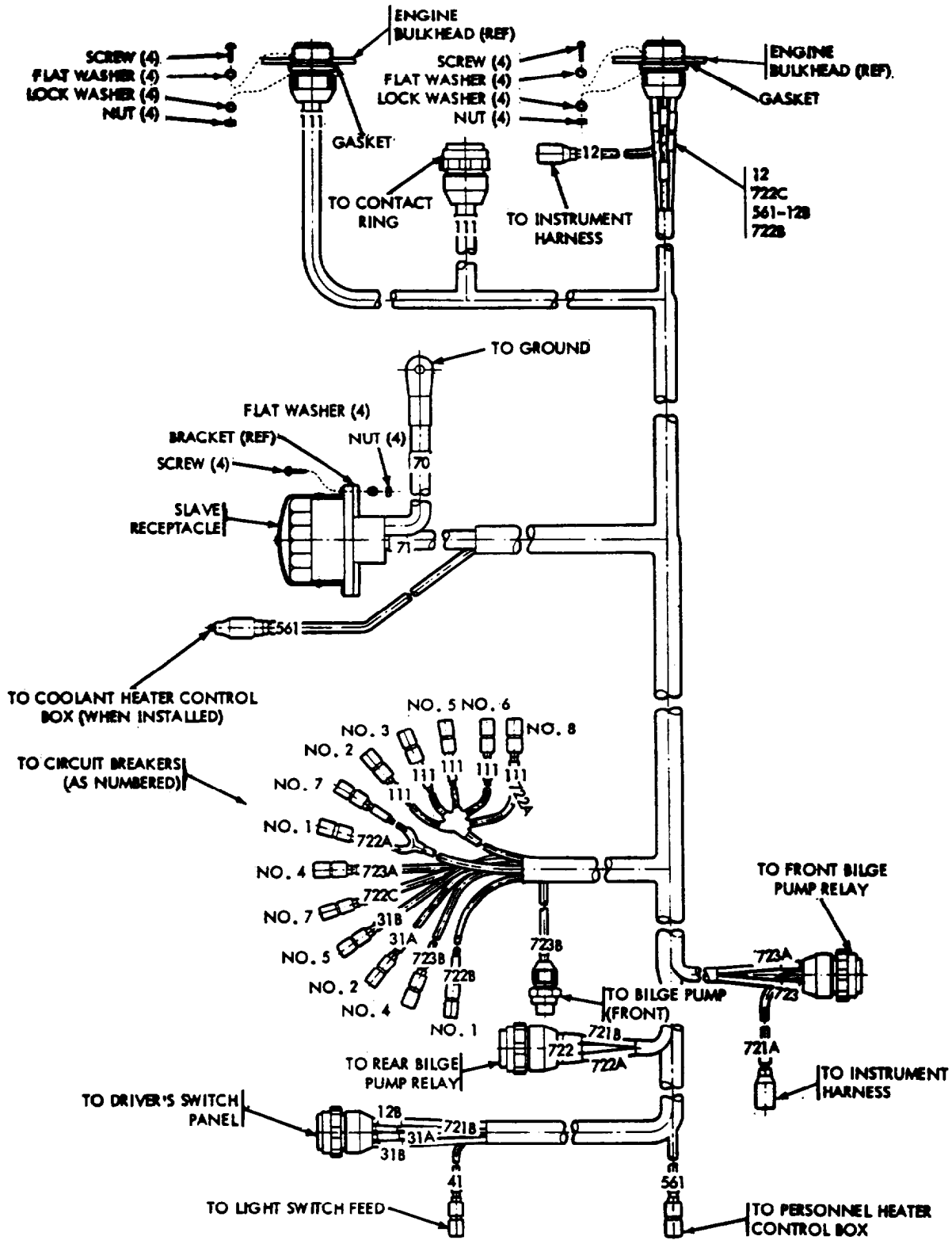

Figure 3-56. Removal/installation - hull front power Wiring harness (2 of 3).

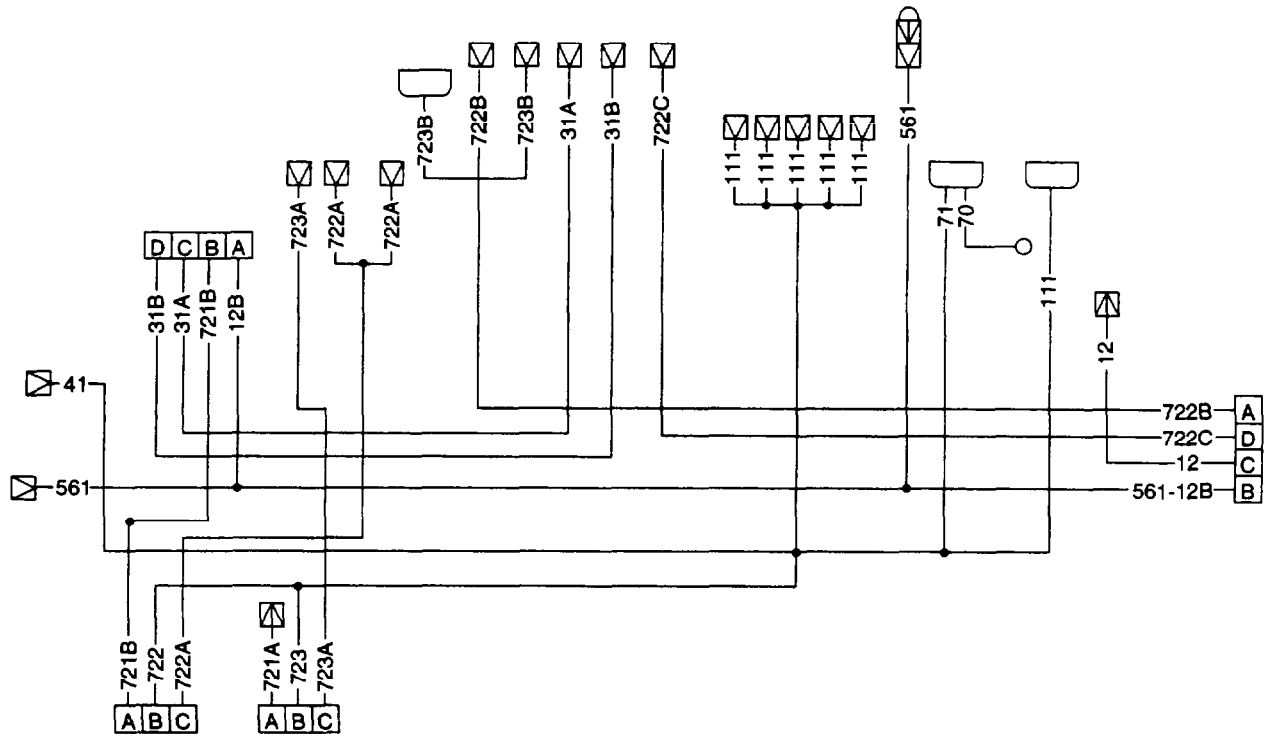

Figure 3-56.1. Removal/installation - hull front power wiring harness (3 of 3).



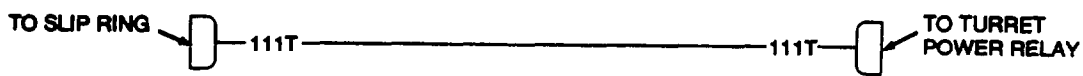
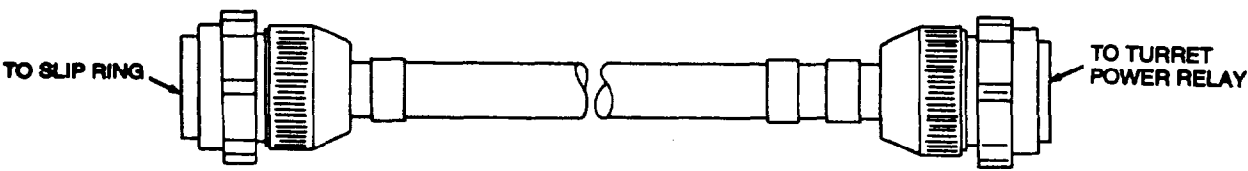
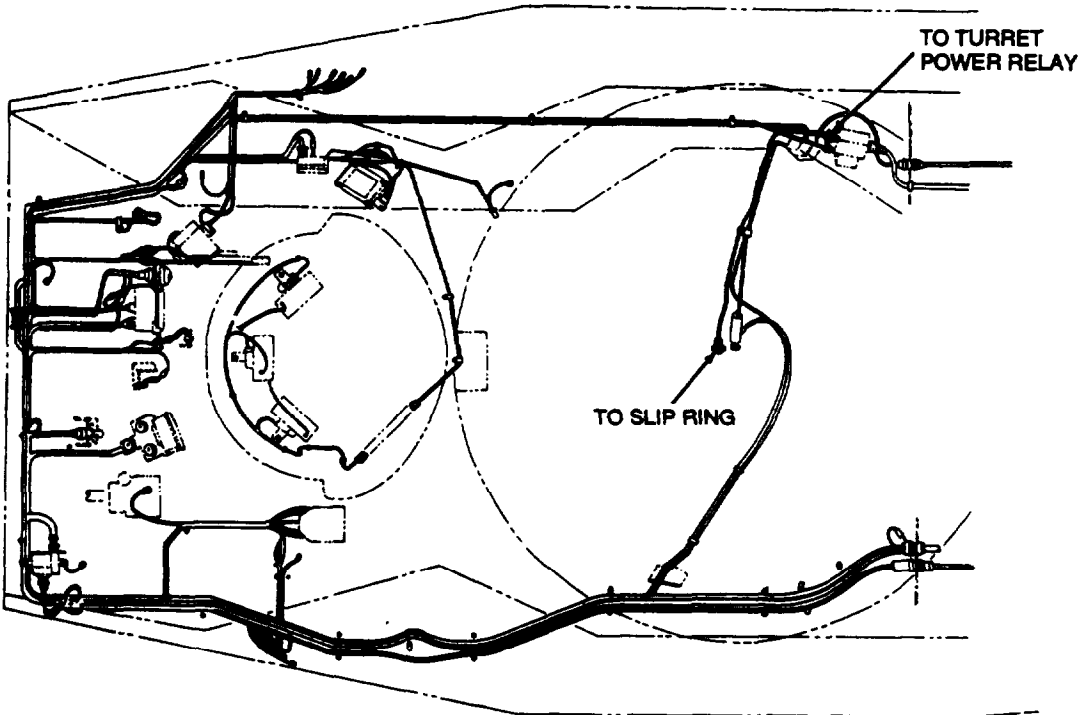
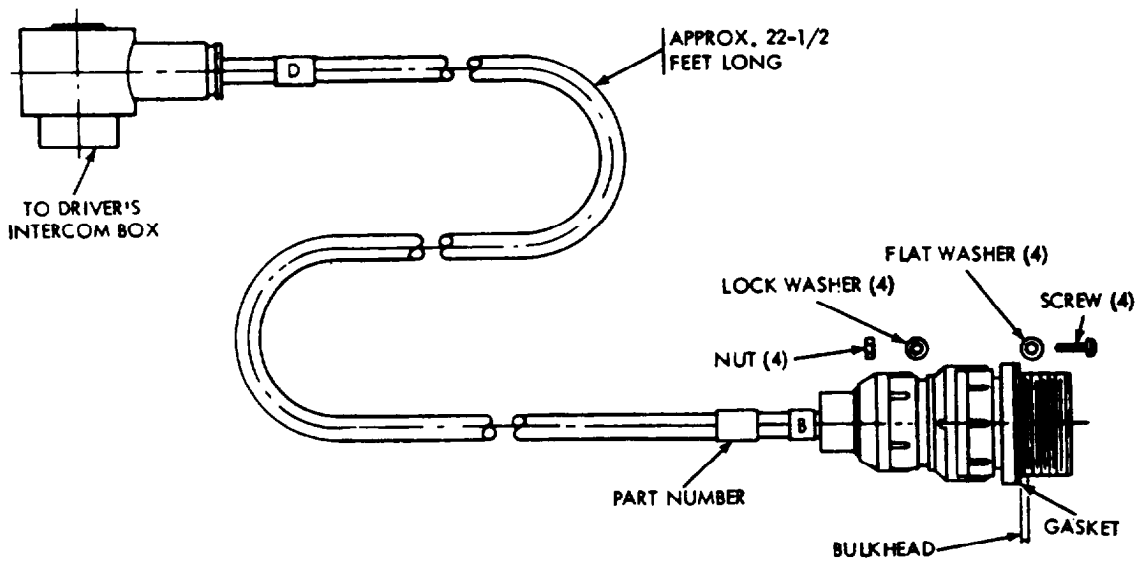
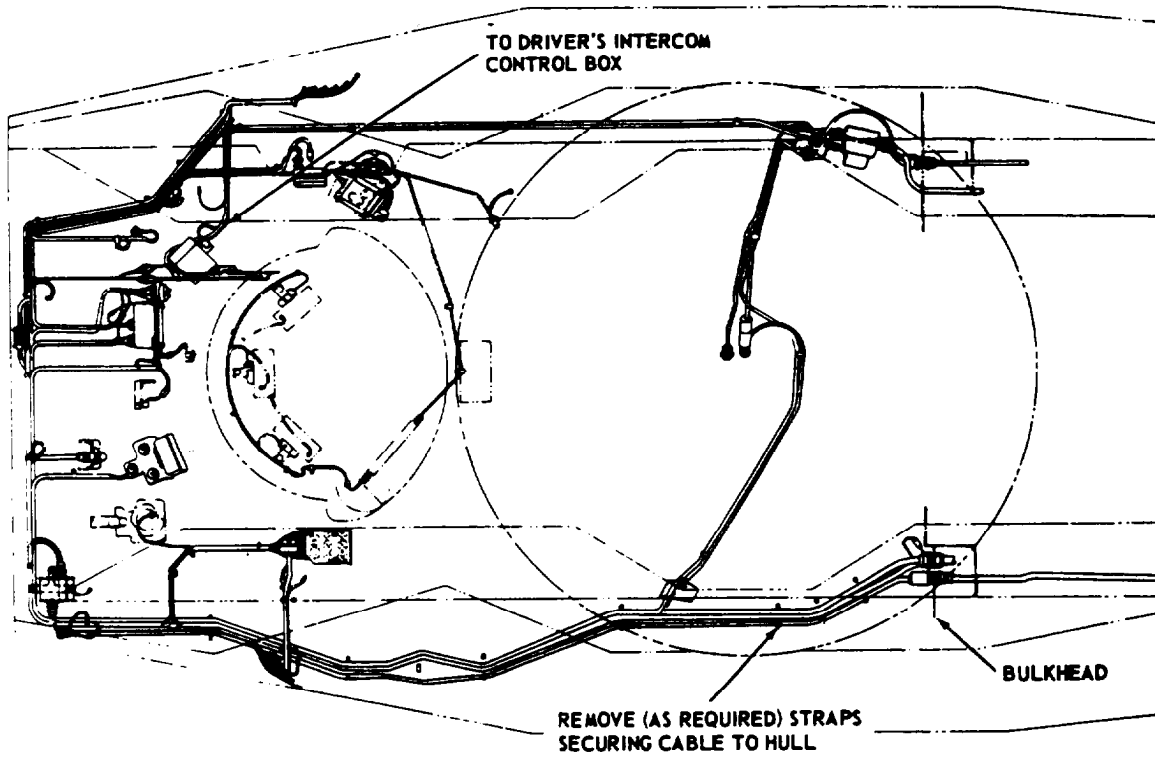

Figure 3-59. Removal/installation - turret power day-to-slip ring.



ORD E70490

Figure 3-60. Removal/installation -driver's intercom-to-head cable assembly (1 of 2).

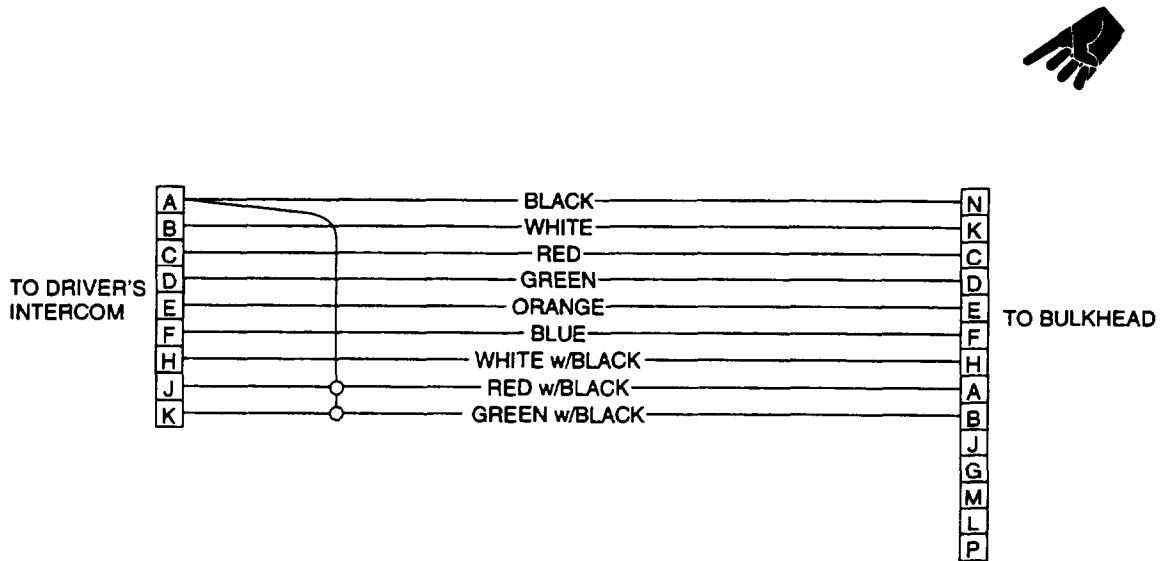

Figure 3-60. Removal/installation -driver's intercom-to-head cable assembly (2 of 2).



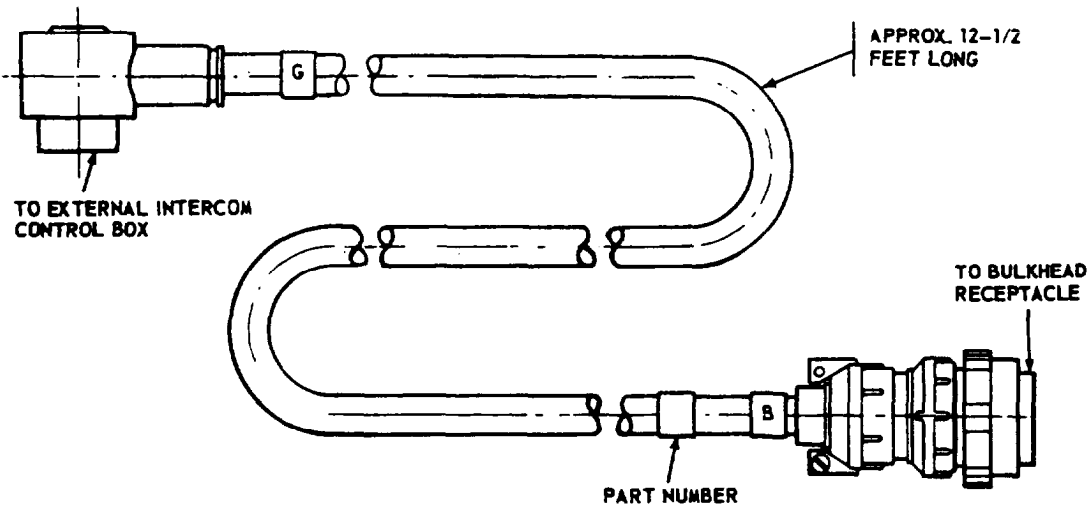
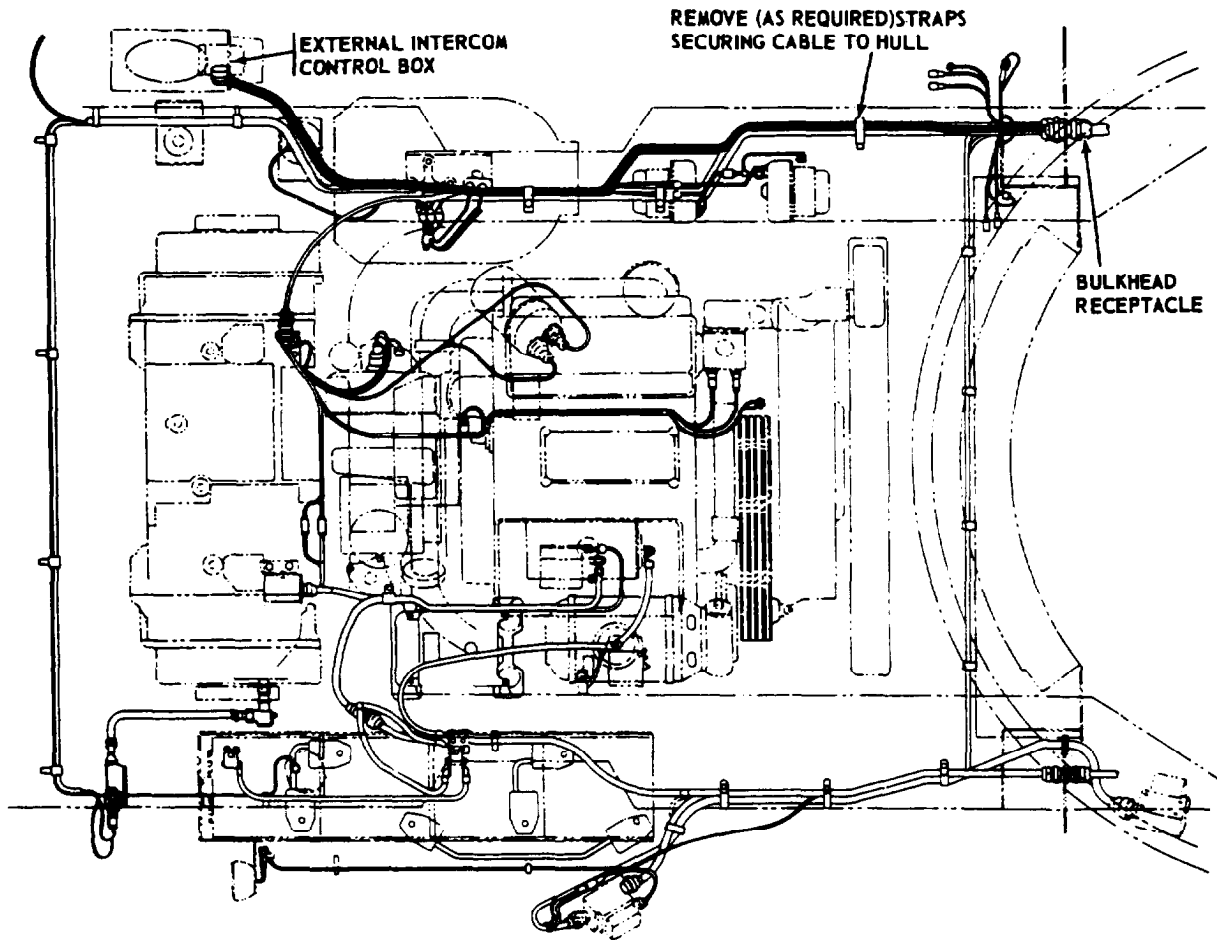

Figure 3-61. Removal/installation - external intercom control box-to-bulkhead cable assembly (1 of 2).

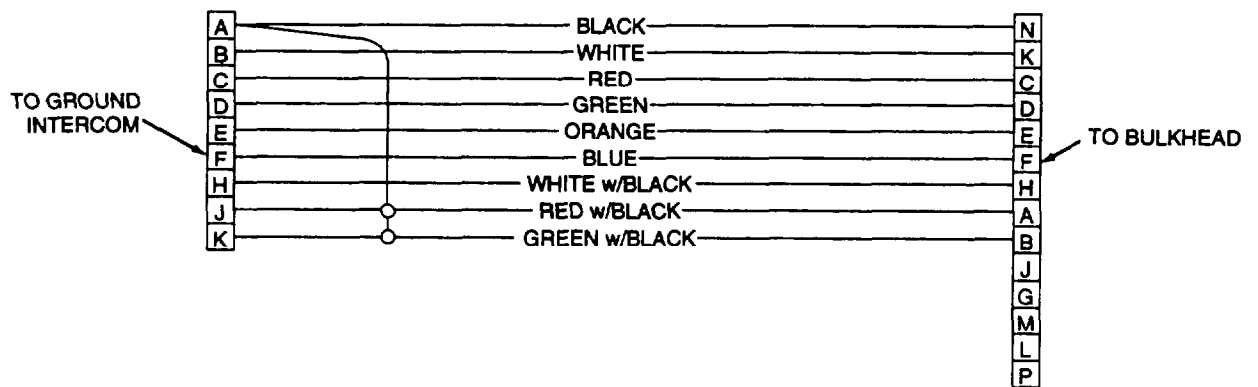
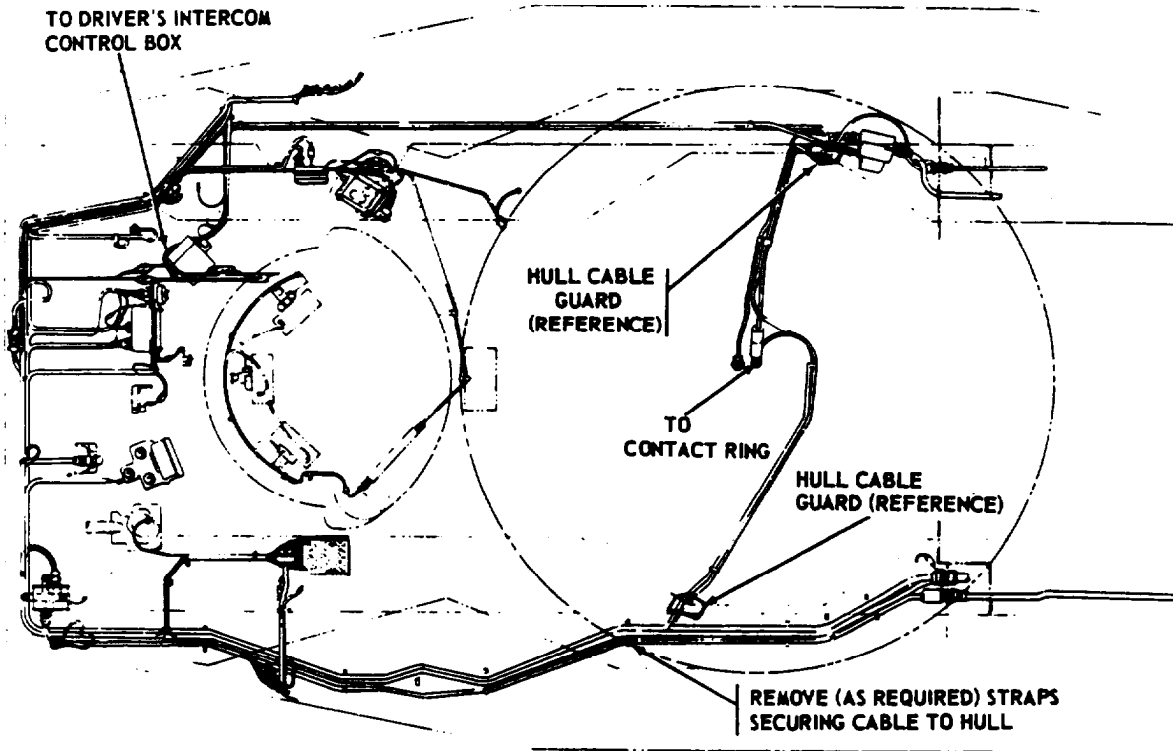

Figure 3-61. Removal/installation-external intercom control box-to-bulkhead cable assembly (2 of 2).



NOTE. EFFECTIVE VEHICLE SERIAL NO. 1325, CABLE LENGTH IS REDUCED FROM 25 FEET TO 15 FEET - 2 INCHES AND CABLE IS RELOCATED FROM HULL LEFT SIDE (SHOWN ABOVE) TO HULL RIGHT SIDE.

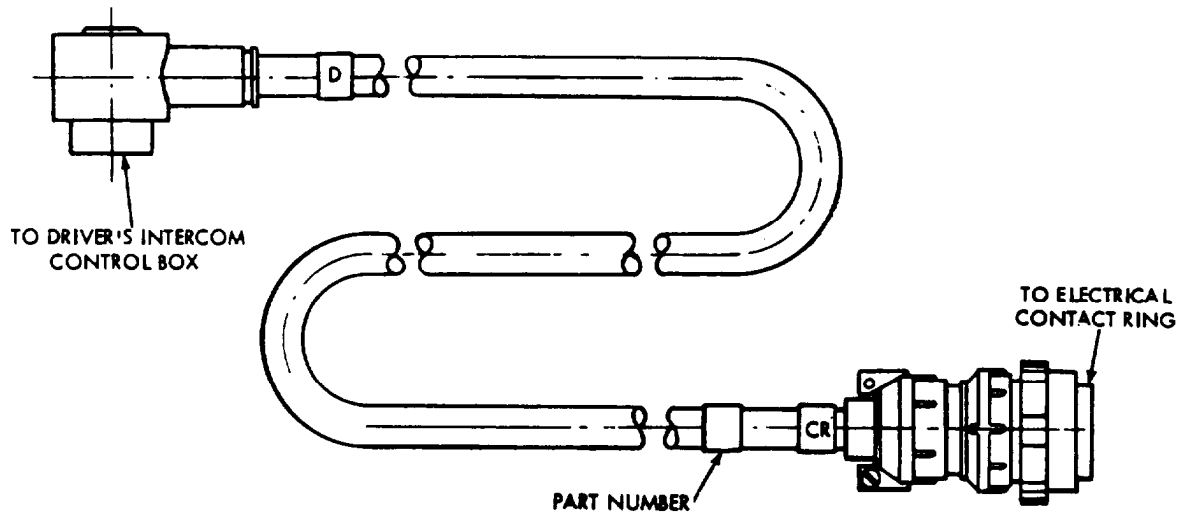

Figure 3-62. Removal/installation -driver's intercom-to-contact ring cable assembly (1 of 2).

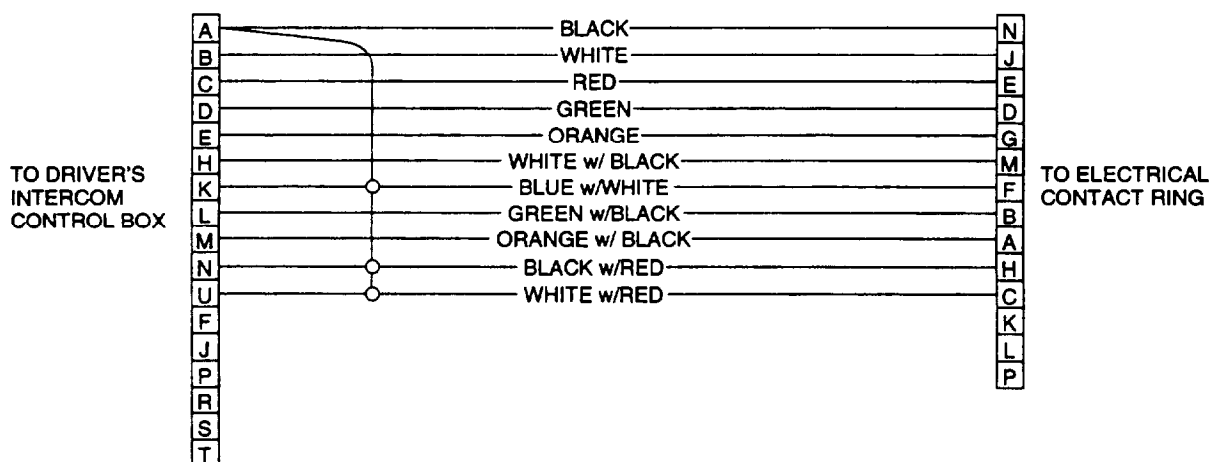
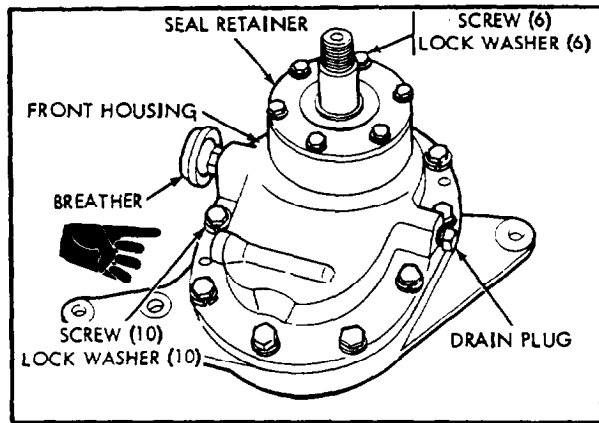
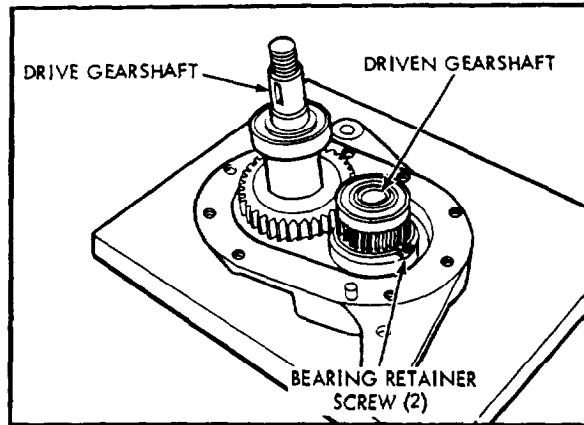

Figure 3-62.1. Removal/installation - driver's intercom-to-contact ring cable assembly (2 of 2).



1. REMOVE DRAIN PLUG, DRAIN OIL FROM ASSEMBLY.
2. REMOVE BREATHER AND CLEAN THOROUGHLY.
3. REMOVE 6 SCREWS, LOCK WASHERS, AND SEAL RETAINER.
4. REMOVE 10 SCREWS, LOCK WASHERS, AND FRONT HOUSING. DISCARD GASKET.



5. PRY UP BEARING RETAINER AND SCREWS. USE CARE IN REMOVAL TO PREVENT DAMAGE TO RETAINER, SCREWS OR HOUSING.
6. LIFT OUT BOTH GEARSHAFT ASSEMBLIES.

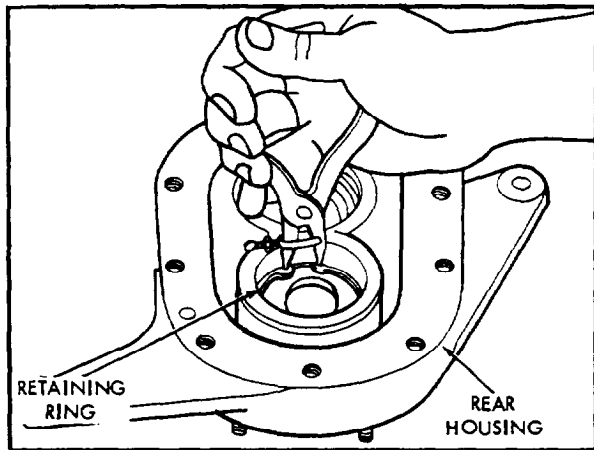

7. REMOVE RETAINING RING FROM REAR HOUSING.

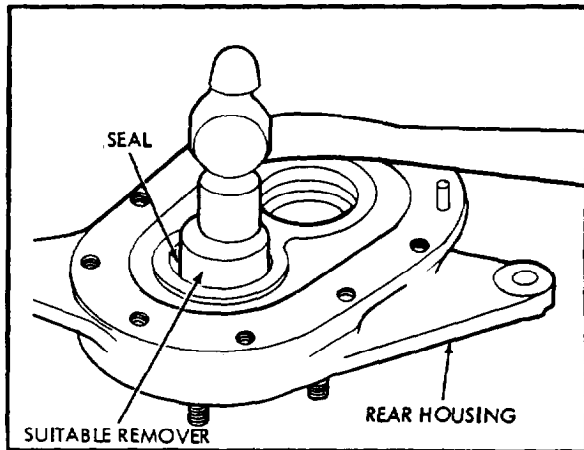

8. REMOVE SEALS FROM REAR HOUSING AND FROM FRONT HOUSING SEAL RETAINER.

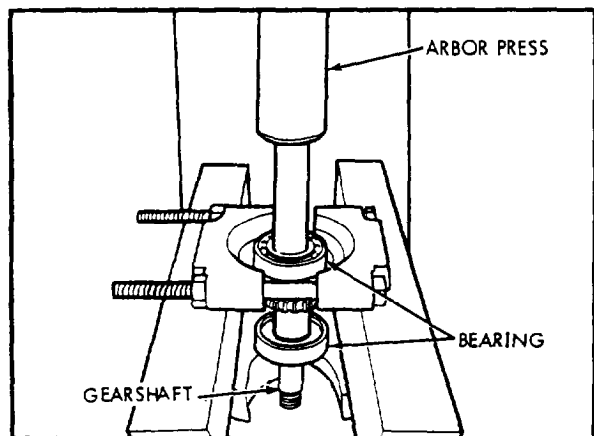

9. REMOVE BEARINGS FROM BOTH GEARSHAFTS USING ARBOR PRESS OR SUITABLE PULLER.

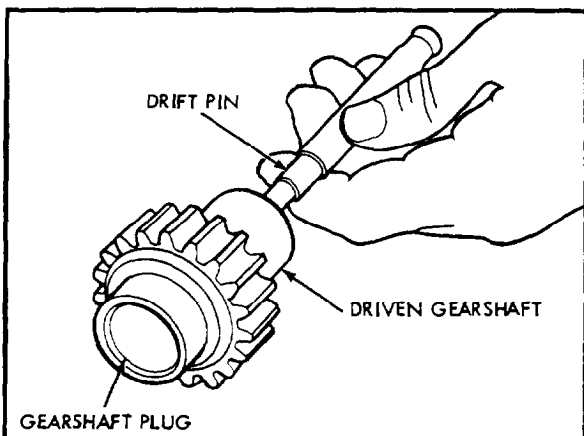

10. DRIVEN GEARSHAFT PLUG MAY BE REMOVED WITH DRIFT PIN IF NECESSARY.

Figure 3-64. Disassembly-generator drive assembly.

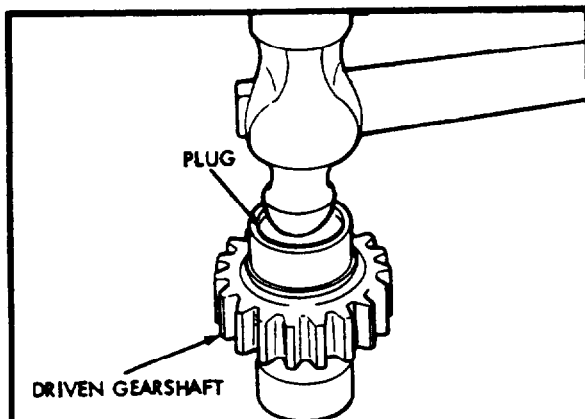

1. COAT EDGE OF PLUG WITH SEALING COMPOUND, 8030-00-656-1426 AND TAP IN PLACE WITH HAMMER.

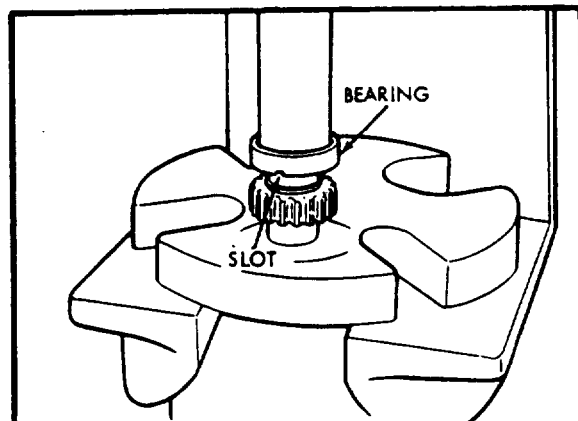

2. PRESS BEARING ON LONG END OF DRIVEN GEARSHAFT SO THAT BEARING SLOT FACES GEAR.

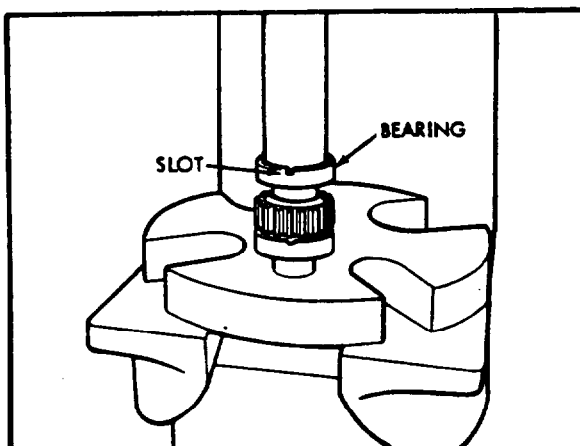

3. PRESS BEARING ON SHORT END OF DRIVEN GEARSHAFT SO THAT BEARING SLOT IS AWAY FROM GEAR.

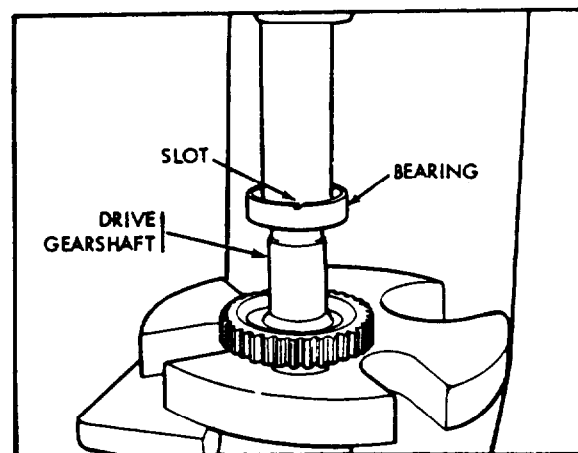

4. PRESS BEARING ON LONG END OF DRIVE GEARSHAFT SO THAT BEARING SLOT IS AWAY FROM GEAR.

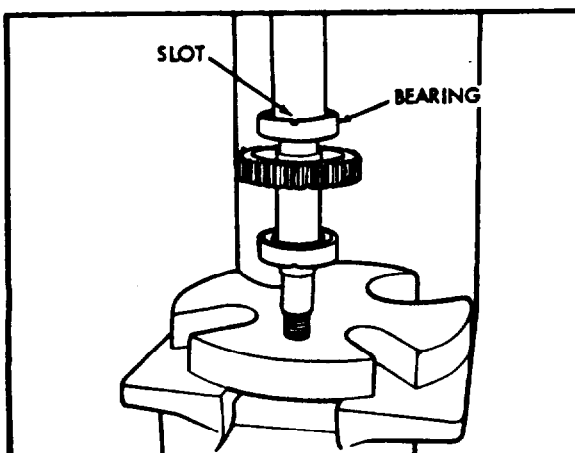

5. PRESS BEARING ON SHORT END OF DRIVE GEARSHAFT SO THAT BEARING SLOT IS AWAY FROM GEAR.

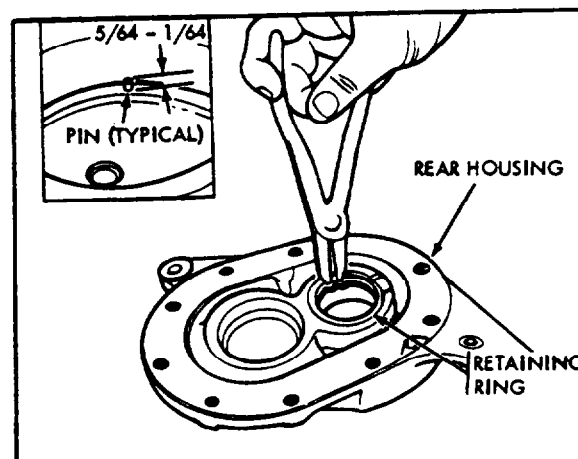

6. PINS IN HOUSINGS SHOULD PROTRUDE  $5/64 - 1/64$  INCH; ADJUST OR REPLACE IF NECESSARY. INSTALL RETAINING RING IN REAR HOUSING; THEN HEAT REAR HOUSING TO  $250^{\circ}\text{F} - 300^{\circ}\text{F}$ .

TA 014824

Figure 3-65. Assembly-generator drive assembly (1 of 2).

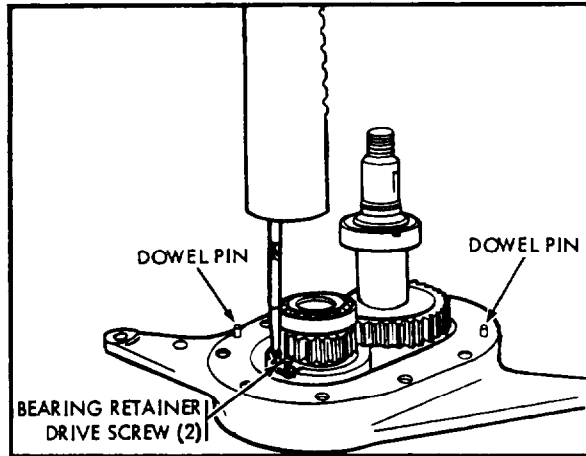

7. DRIVE HOUSING DOWEL PINS FLUSH WITH HOUSING SO HOUSINGS MAY BE ROTATED SLIGHTLY TO FACILITATE ALIGNMENT OF BEARING RETAINING PIN.
8. INSTALL GEARSHAFTS IN APPROPRIATE BEARING BORES IN REAR HOUSING. ALIGN DRIVE GEARSHAFT BEARING SLOT WITH PIN IN HOUSING AND DRIVEN GEARSHAFT BEARING SLOT WITH SLOT IN REAR HOUSING. GREASE DRIVEN GEAR BEARING SO ITS POSITION MAY BE MAINTAINED DURING ALIGNMENT OF BEARING RETAINING PINS.
9. INSTALL BEARING RETAINER INTO MILLED SLOT IN HOUSING, COAT DRIVE SCREWS WITH SEALING COMPOUND 8030-00-081-2339 AND PRESS INTO HOUSING.
10. AFTER HOUSING HAS COOLED TO ROOM TEMPERATURE, PLACE GASKET IN POSITION ON HOUSING.

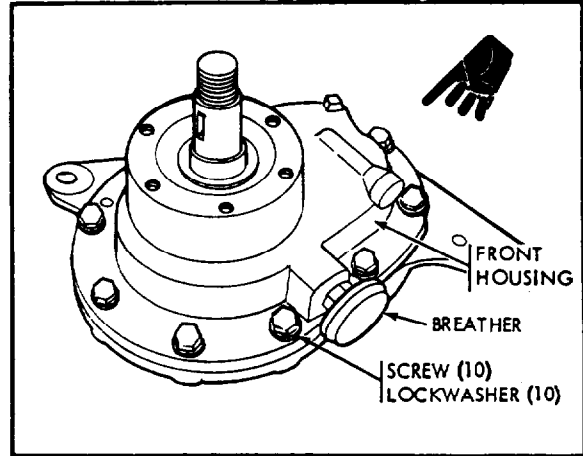

11. HEAT FRONT HOUSING TO 250° - 300° F. AND ASSEMBLE TO REAR HOUSING AND GEARSHAFT UNITS MAKING SURE PINS IN FRONT HOUSING ALINE WITH SLOTS IN BEARING OUTER RACES.
12. DRIVE HOUSING DOWEL PINS INTO POSITION TO ALINE FRONT AND REAR HOUSINGS.
13. INSTALL SCREWS, LOCK WASHERS, AND TIGHTEN SCREWS TO 2-3 LB-FT.
14. AFTER ASSEMBLY HAS COOLED, TIGHTEN SCREWS TO 20-25 LB-FT, AND INSTALL DRAIN PLUG, FILL PLUG, AND BREATHER.

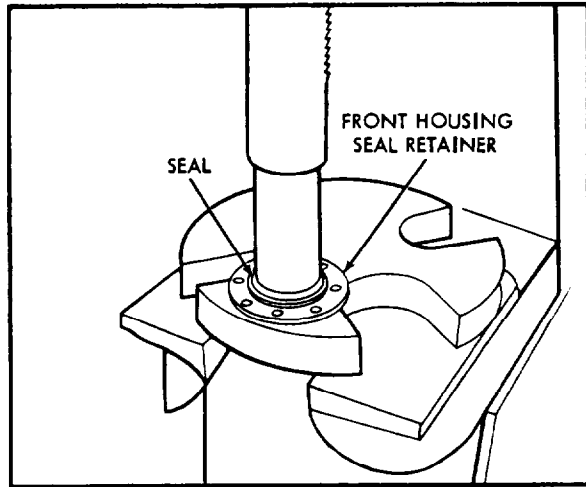

NOTE. SOAK SEALS IN OE-30 OIL FOR 30 MINUTES BEFORE ASSEMBLY.

15. PRESS SEAL INTO FRONT HOUSING SEAL RETAINER.
16. INSTALL SEAL RETAINER ON FRONT HOUSING WITH 6 SCREWS AND LOCKWASHERS AND TIGHTEN TO 14 LB-FT.

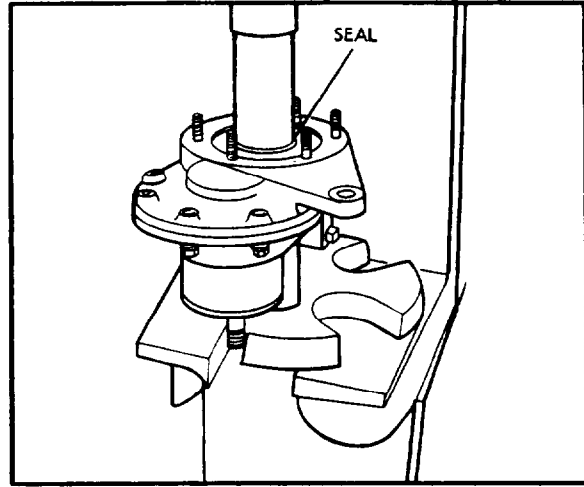

NOTE. SOAK SEALS IN OE-30 OIL FOR 30 MINUTES BEFORE ASSEMBLY.

17. INSTALL SEAL IN REAR HOUSING.
18. FILL WITH OIL TO PROPER LEVEL (LO 9-2350-230-12).

NOTE. IF NEW STUD(S) ARE INSTALLED IN REAR HOUSING, APPLY SEALING COMPOUND 8030-00-081-2339 TO THREADS.

Figure 3-66. Assembly-generator drive assembly (2 of 2).

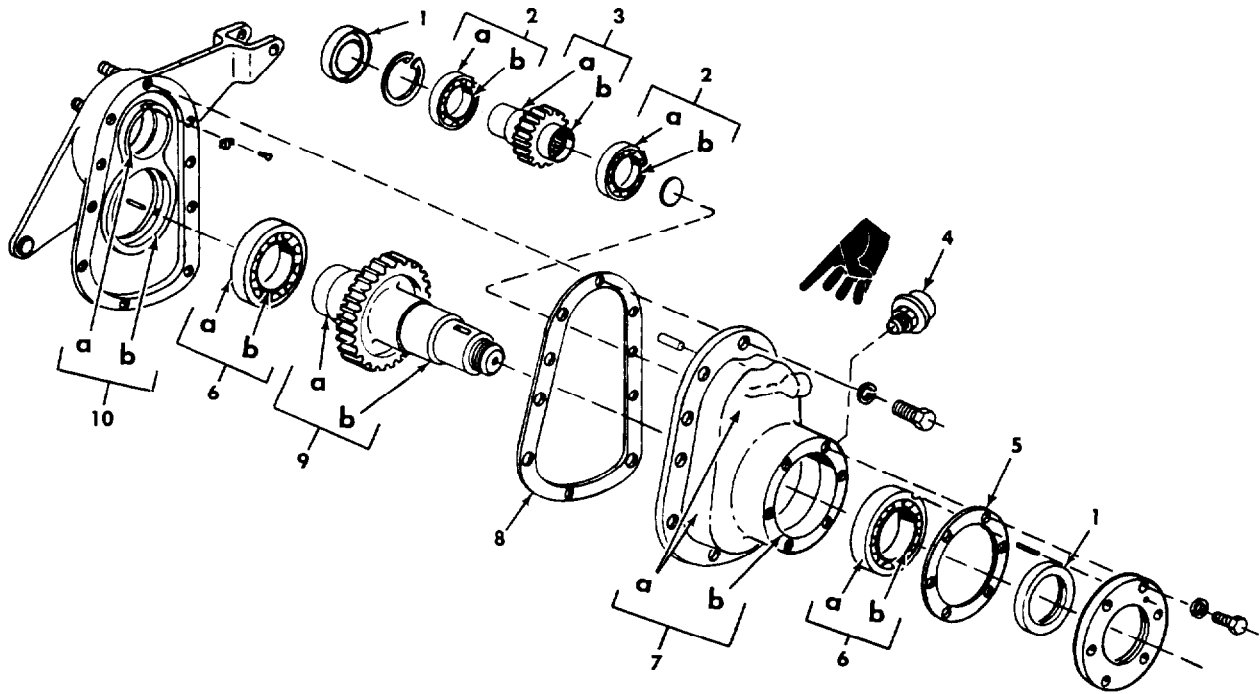

Figure 3-67. Generator drive assembly - repair data.

Table 3-7. Generator Drive Assembly - Repair Data (see fig 3-67)

Reference	Inspection data and points of measurement	Size and fit of new parts	Field repair limit
1	Seal - 5330-00-912-9509 Replace		
2	Bearing- 3110-01-087-0313		
a	OD	2.1649 - 2.1654	**
b	ID	1.1806 - 1.1813	1.1815
3	Driven Gearshaft - 3040-00-918-0576		
a&b	OD of Bearing Journals	1.1810 - 1.1813	
2b-3ab	Fit of Bearings on Gearshaft	.0007T - .003L	.0003L
	OD of Gear over two .1728 Dia. Pins	2.1300 - 2.1320	2.1299
	Backlash with Gearshaft (10)	.003-.005	.007
4	Breather - 2815-00-4644542 clean thoroughly with cleaning solvent.		
5	Gasket - 5330-00-912-9509 Replace-		
6	Bearing- 3110-01-315-9564		
a	OD	2.4404 - 2.4409	**
b	ID	1.1806 - 1.1811	1.1813
7	Front Housing, 12250304 (Part of Matched Set 3040-00-159-8962)		
a	Dia. of Driven Gearshaft Bearing Bore	2.1652 - 2.1657	.
b	Dia. of Drive Gearshaft (7) Bearing Bore	2.4407 - 2.4412	.
8	Gasket - 5330-01-041-3397 Replace		
9	Drive Gearshaft - 3040-00-918-4162		
a & b	OD of Rearing Journals	1.1810 - 1.1813	1.1809
6b-ab	Fit of Bearing on Gearshaft	.0007T - .0001L	.0002L
	OD of Gear Over Two .1728 Dia Ring	3.8223 - 3.8343	3.8313
	Backlash with Gearshaft (3)	.003 - .005	.0055
10	Rear Housing - 1225031 (Part of Matched Set 3040-00-159-8962)		

Note. See paragraph 2-12 on repair limits marked \*, \*\*, T, or L.



Table 3-7. Generator Drive Assembly - Repair Data (see fig. 3-67) - Continued

Reference	Inspection data and points of measurement	Size and fit of new parts	Field repair limit
a	Dia. of Driven Gearshaft Bearing Bore	2.1652 — 2.1657	•
b	Dia. of Drive Gearshaft Bearing Bore	2.4407 — 2.4412	•
2a-7a	Fit of Bearing in Housing	.0002T — .0008L	•
2a-10a			
6a-10b	Fit of Bearing in Housing	.0002T — .0008L	•
6a-7b			

Note. See paragraph 2-12 on repair limits marked •, \*\*, T, or L.

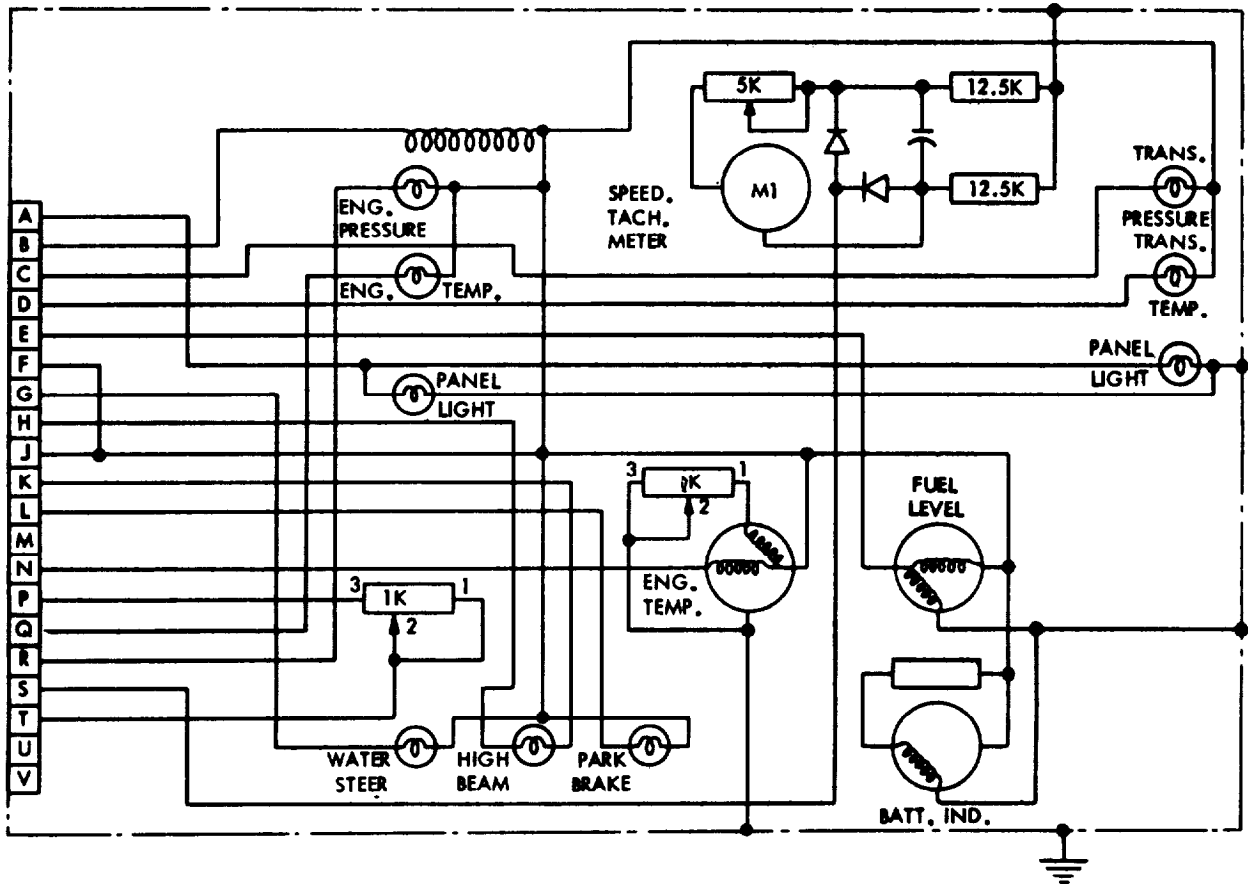

CIRCUIT NUMBER	CONNECTOR PIN LETTER	CONNECTED TO
432A	A	PANEL LIGHTING
323C	B	ODOMETER
315	C	TRANSMISSION PRESSURE
314	D	TRANSMISSION TEMPERATURE
32A	E	FUEL GAGE SENDER
32C	F	FUEL GAGE SENDER
50A	G	WATER STEER ON
429	H	HIGH BEAM
31C	J	BATTERY
429	K	HIGH BEAM
50B	L	PARKING BRAKE ON
	M	SPARE
34	N	ENGINE TEMPERATURE GAGE
322	P	TACHOMETER
39	Q	ENGINE TEMPERATURE
313	R	ENGINE PRESSURE
322-323	S	SPEEDOMETER - TACHOMETER COMMON
322A	T	TACHOMETER SIDE OF SWITCH
	U	SPARE
	V	SPARE

ORD E70477

Figure 3-68. Driver's indicator panel wiring diagram.

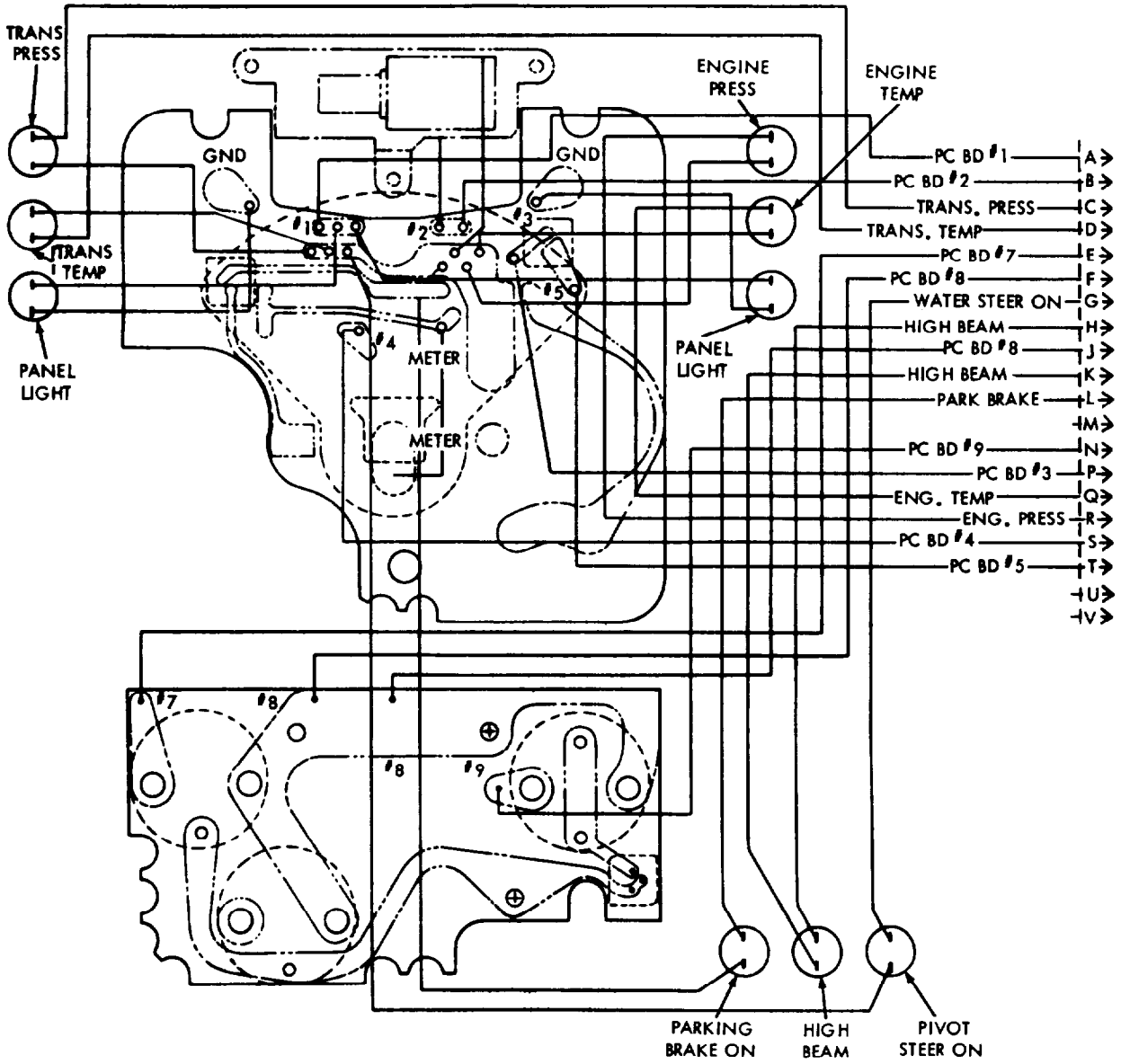

ORD E70505

Figure 3-69. Driver's indicator panel instrument cluster assembly wiring diagram.

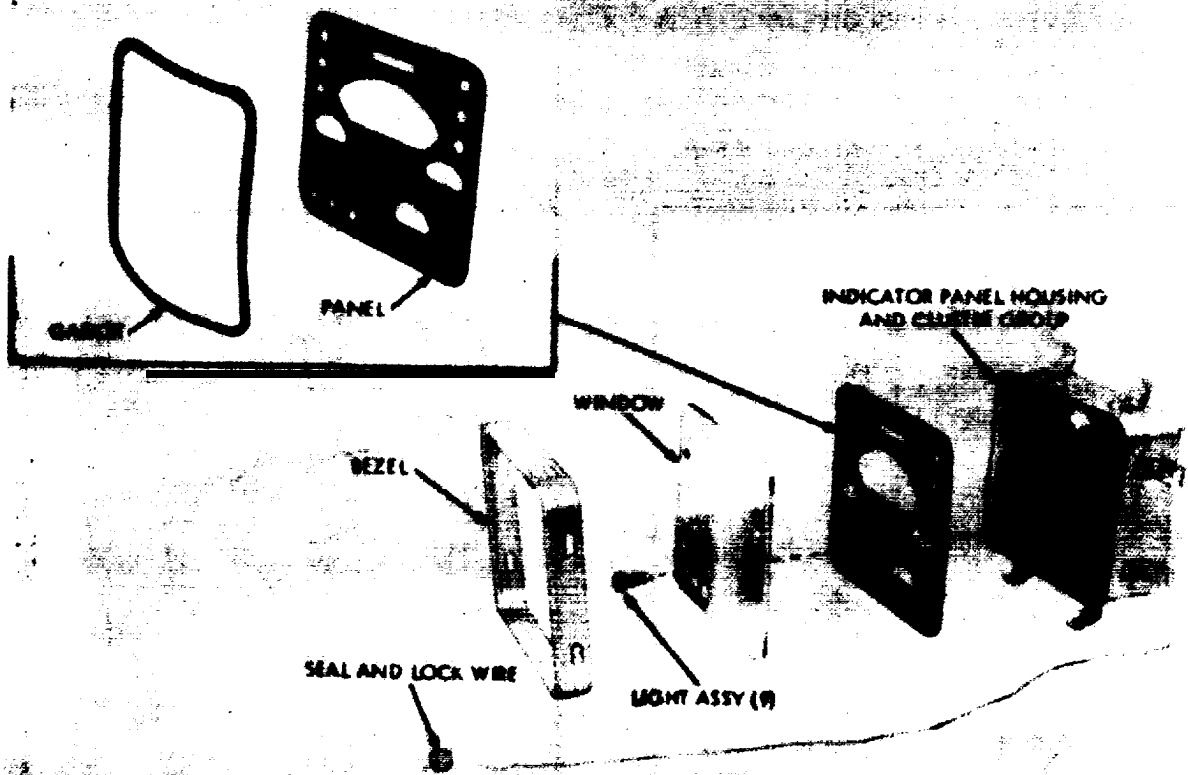
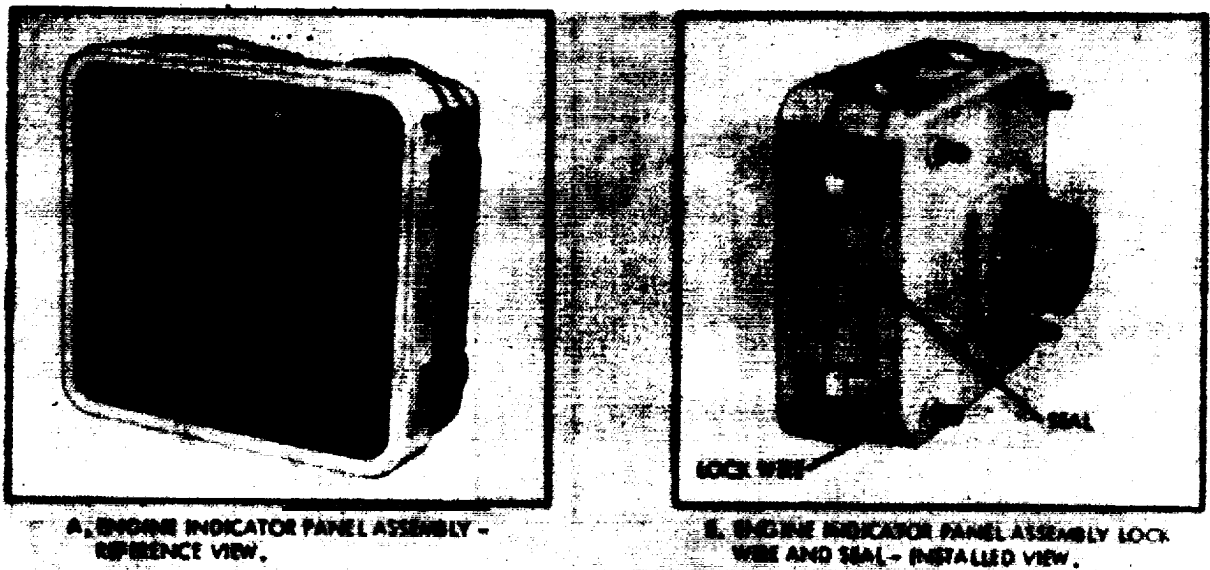

**DISASSEMBLY**

1. REMOVE 9 LIGHT ASSEMBLIES FROM FRONT OF INDICATOR PANEL ASSEMBLY.
2. CUT LOCK WIRE AND REMOVE LOCK WIRE WITH SEAL FROM HOUSING LATCHES.
3. LIFT 8 LATCHES TO DISCONNECT BEZEL FROM INDICATOR PANEL HOUSING AND REMOVE BEZEL, WINDOW, AND PANEL WITH GASKET.
4. REMOVE GASKET FROM PANEL IF NECESSARY. REMOVAL OF GASKET CAN STRETCH RUBBER MATERIAL AND REQUIRE REPLACEMENT OF GASKET.

OR D F70506

Figure 3-70. Disassembly/assembly - driver's indicator panel assembly (1 of 3).

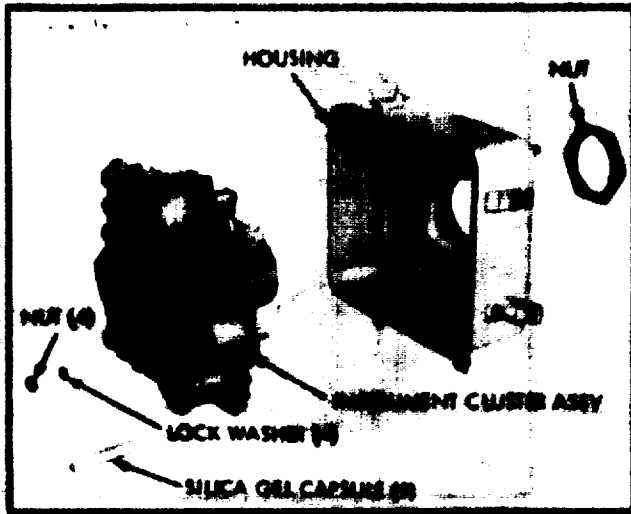

5. REMOVE 4 NUTS AND LOCK WASHERS SECURING INSTRUMENT CLUSTER ASSEMBLY TO HOUSING POSTS.
  6. REMOVE LARGE NUT SECURING HARNESS RECEPTACLE TO HOUSING.
  7. CAREFULLY SLIDE OUT SILICA GEL CAPSULES FROM CUTOUTS IN CIRCUIT BOARD.
  8. LIFT OUT INDICATOR PANEL CLUSTER ASSEMBLY.
- NOTE: IF CAPSULE COLOR IS OF A BROWNISH HUE, THEY MUST BE DRIED OUT BEFORE BEING REINSTALLED; NORMAL COLOR IS BLUE.

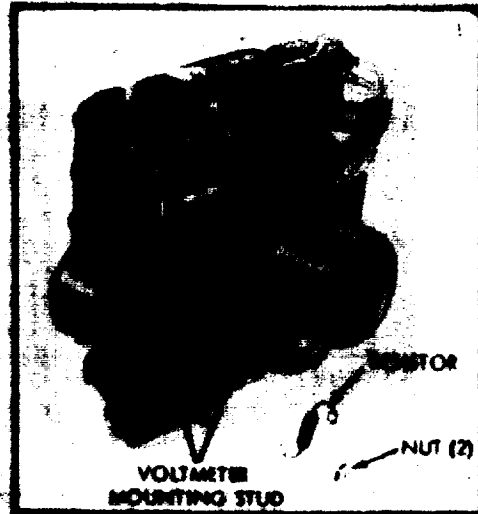

9. REMOVE 2 NUTS SECURING RESISTOR TO 2 MOUNTING STUDS OF VOLTMETER AT REAR OF SMALL CIRCUIT BOARD.

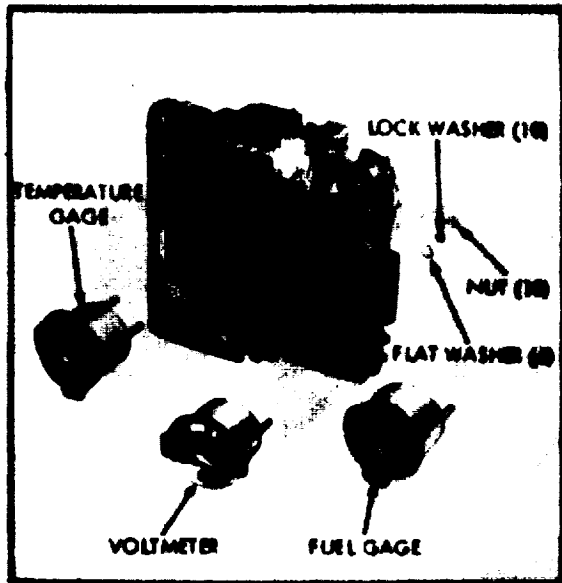

10. REMOVE 4 NUTS, 4 LOCK WASHERS, AND 2 FLAT WASHERS TO REMOVE TEMPERATURE GAGE.
11. REMOVE 3 NUTS, 3 LOCK WASHERS, AND 2 FLAT WASHERS TO REMOVE VOLTMETER.
12. REMOVE 3 NUTS, 3 LOCK WASHERS, AND 2 FLAT WASHERS TO REMOVE FUEL GAGE.

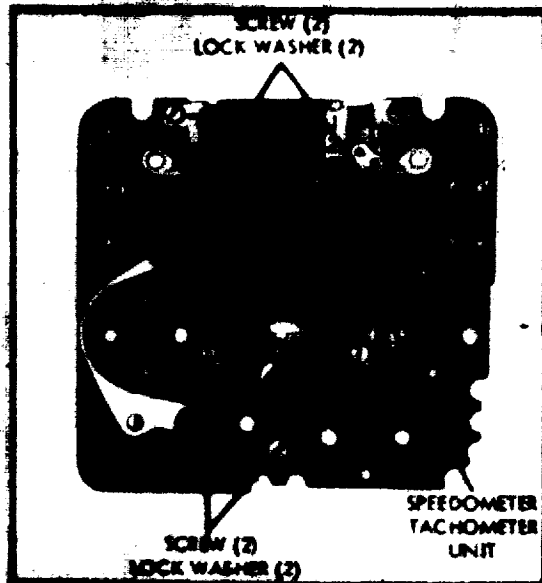

13. REMOVE 4 SCREWS AND LOCK WASHERS SECURING SPEEDOMETER/TACHOMETER UNIT TO CIRCUIT BOARD.
- NOTE: DO NOT REMOVE NUT OR SETSCREW AT PIVOT POINT OF INDICATOR NEEDLE WHERE LEAD TERMINAL IS ATTACHED. DISTURBANCE OF COMPONENTS AT THIS POINT COULD DESTROY CALIBRATION OF INSTRUMENT.

ORD E70507

Figure 3-71. Disassembly/assembly - driver's indicator panel assembly (3 of 3).

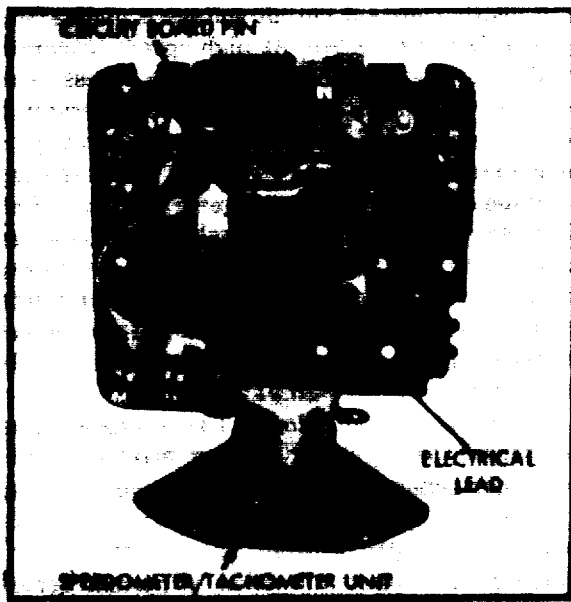

14. LIFT OUT SPEEDOMETER/TACHOMETER UNIT AND PLACE ON SUPPORT SO WEIGHT OF INSTRUMENT IS NOT ON INDICATOR NEEDLE.  
 15. UNSOLDER LEAD FROM CIRCUIT BOARD PIN AND REMOVE UNIT.

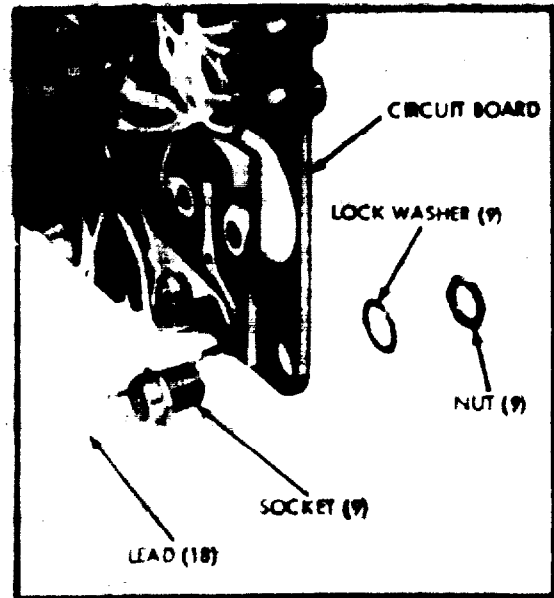

16. TO REMOVE EACH SOCKET:  
 A. REMOVE NUT AND LOCK-WASHER FROM FRONT OF CIRCUIT BOARD.  
 B. SLIDE SOCKET FROM REAR OF CIRCUIT BOARD AND UNSOLDER LEADS.

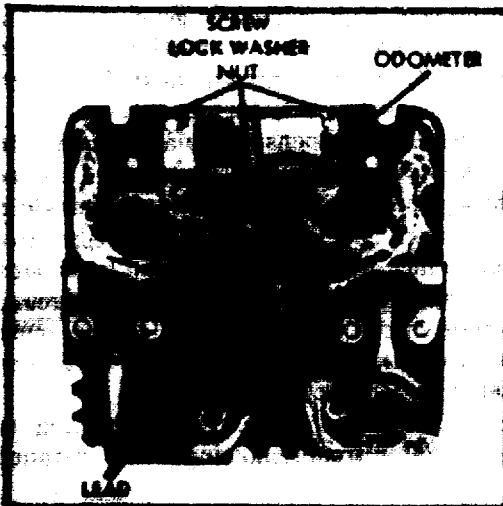

17. REMOVE 3 NUTS, LOCK WASHERS AND SCREWS SECURING ODOMETER TO CIRCUIT BOARD, UNSOLDER TWO BLACK LEADS AT CIRCUIT BOARD AND REMOVE ODOMETER.

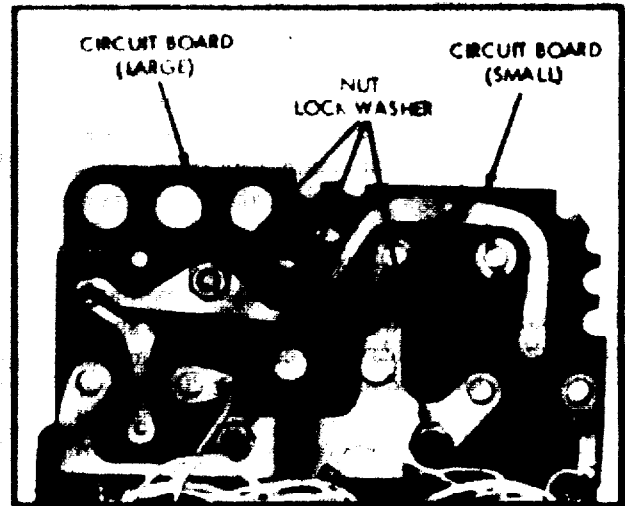

18. REMOVE 3 NUTS AND LOCK WASHERS AND UNSOLDER HARNESS LEADS TO SEPARATE CIRCUIT BOARDS.

**ASSEMBLY NOTE.**

ASSEMBLE COMPONENTS IN REVERSE ORDER OF REMOVAL. REFER TO WIRING DIAGRAMS, FIGS. 3-68 AND 3-69 TO ASSURE PROPER INSTALLATION OF HARNESS WIRING AND CONNECTIONS. REPLACE ALL DEFECTIVE COMPONENTS.

TA 014825

Figure 3-72. Disassembly/assembly - driver's indicator panel assembly (3 of 3).

### 3-34. Repair of Generator Voltage Regulator

a. *General.* The solid state generator current and voltage regulator perform the following functions:

(1) Connects generator to batteries when generator voltage is above battery voltage, and disconnects generator when generator voltage falls below battery voltage.

(2) Controls generator field current to maintain a nearly constant generator output voltage.

(3) Limits generator maximum output current preventing generator overload.

(4) Incorporates a "Failsafe" circuit which is automatically activated in event of regulator malfunction or circuit interruption.

b. *Functional Operation.*

(1) *General.* Refer to figures 3-74,3-77,3-79, and 3-80 for schematic and wiring diagrams.

(2) *Generator startup.* When generator is shut down, main contactor ( $K_1$ ) is open, and field buildup relay ( $K_2$ ) and failsafe relay ( $K_3$ ) are closed. When generator rotates, a small voltage is generated due to residual magnetism, and current flows to generator field through closed contacts of field buildup relay. Generator voltage continues to rise as speed is increased. When voltage reaches 12 to 16 volts (approx. 900 RPM), field buildup relay contacts ( $K_2$ ) open and current continues to generator field through regulator power transistors. Generator voltage drops slightly, since power transistors have some resistance, but voltage continues to rise as generator speed increases.

(3) *Voltage control.* The main contactor closes when generator voltage exceeds battery voltage. Voltage continues to rise and will level off between 26 and 30 volts depending on rheostat adjustment. Up to this point generator has been "full fielded" (regulator has allowed maximum field current to flow). As speed is increased, regulator holds field current to amount which will produce adjusted output voltage. The power transistors switch on for a short but fixed period and then switch off. If voltage remains low, transistors immediately switch on and off repeatedly until voltage reaches set point. Transistors remain off when voltage is higher than set point. Due to high switching frequen-

cy, a nearly constant output voltage is generated.

(4) *Current control.* At high speeds, generator is capable of producing high current in excess of rated capacity and would overheat and fail. Generator drive would be strained. The regulator prevents this by limiting generator current. As generator produces current, a voltage drop appears across generator series field or interpole connection proportional to generator output current. The voltage is negative with respect to ground and is sensed by equivalent to current limit setting; regulator reacts to prevent this voltage from increasing further by decreasing generator field current and output voltage.

(5) *Generator shutdown.* The interpole signal is also sensed by regulator causing main contactor to open when generator is shut down. As generator speed is decreased, generator voltage falls below battery voltage and current from battery flows through generator in opposite direction to normal generated current (generator actually runs like a motor under this condition). Due to this reverse current, a voltage appears across generator interpole connection proportional to reverse current. This voltage is positive with respect to ground, and is sensed by regulator which opens main contactor.

(6) *Failsafe protection.* The regulator includes circuitry to prevent high voltage or generator motoring due to malfunction or broken connections. The failsafe circuit relay ( $K_3$ ) opens generator field if power transistors fail to switch off, thereby preventing high voltage. The relay also opens if regulator ground wire is broken. The failsafe circuit opens main contactor under these conditions, and also when interpole connection is broken. The failsafe relay coil is connected to the battery which holds relay open (and locks out this system) once a malfunction has triggered circuit. In order to reset circuit, generator (and engine) must be shut down and either positive or negative battery cable momentarily disconnected.

c. *Troubleshooting Vehicle.* Troubleshooting table 2-1 lists regulator troubleshooting when installed in vehicle.

d. *Disassembly and Assembly.* Refer to figures 3-73,3-75, and 3-76.

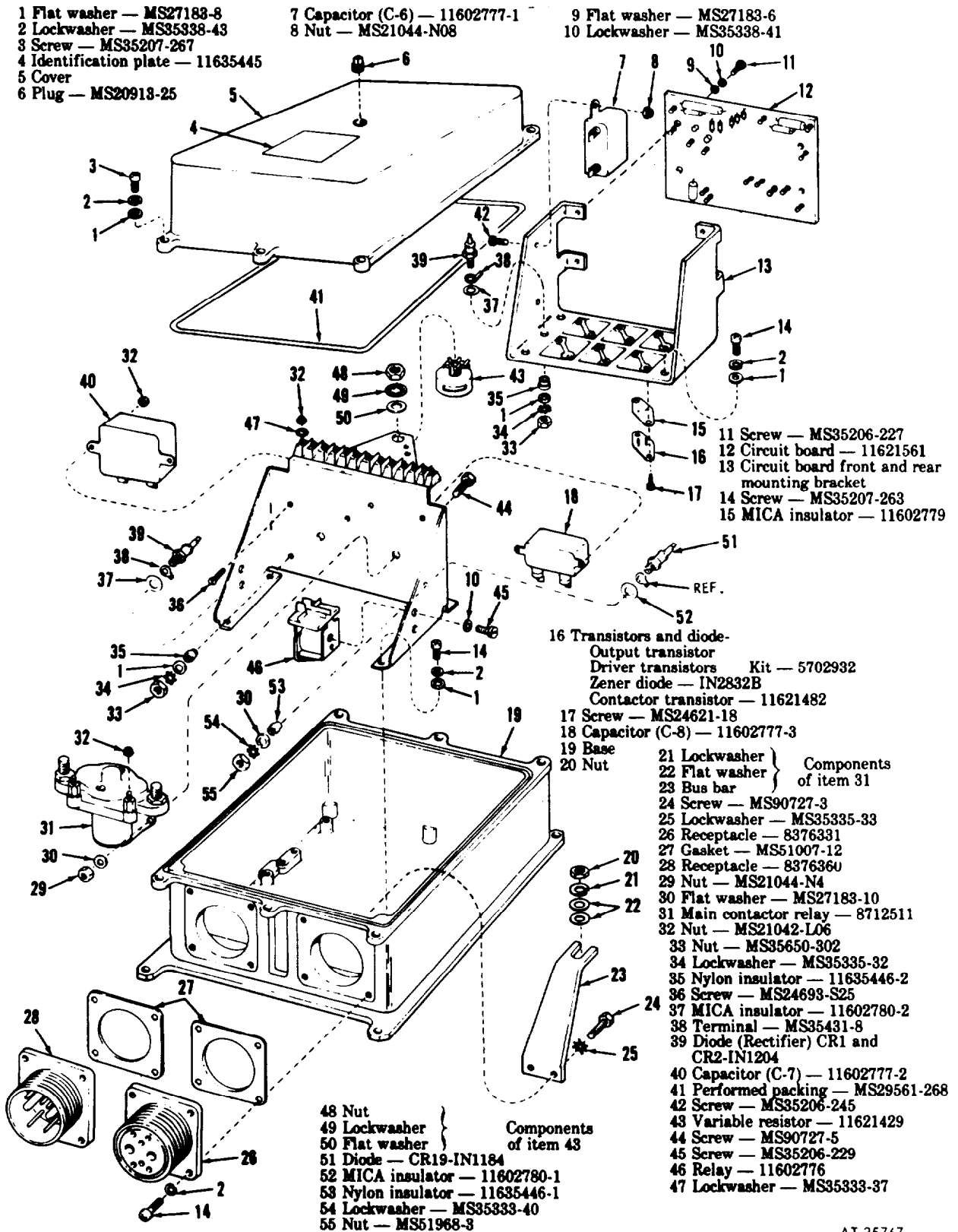

AT 35767

Figure 3-73. Generator voltage regulator - 11621812 - exploded view.







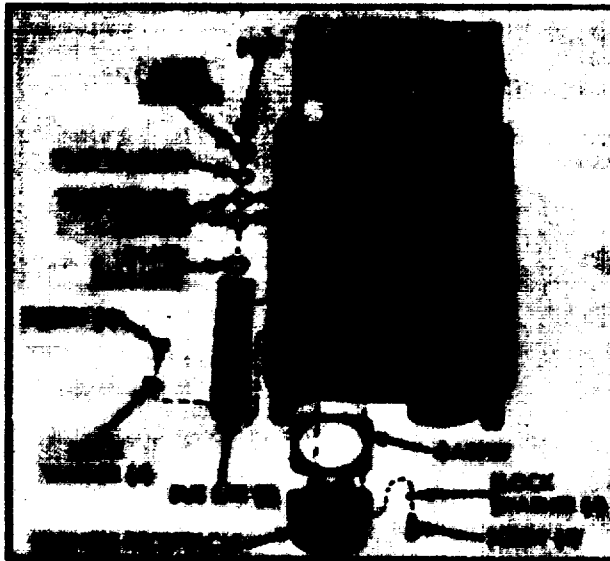

9. REMOVE NUT, LOCK WASHER, AND FLAT WASHER ATTACHING BRACKET TO MOUNT SCHEMATIC BOARD. REMOVE NUT, LOCK WASHER, AND FLAT WASHER ATTACHING BRACKET TO MOUNT SCHEMATIC BOARD. REMOVE NUT, LOCK WASHER, AND FLAT WASHER ATTACHING BRACKET TO MOUNT SCHEMATIC BOARD.

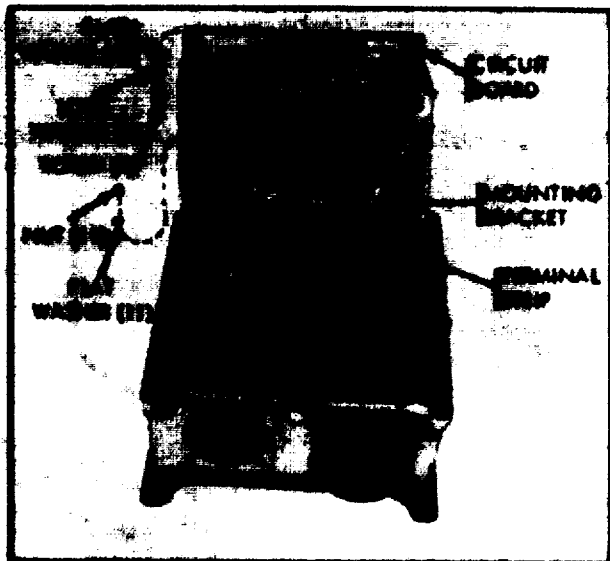

13. REMOVE 4 SCREWS AND WASHERS ATTACHING CIRCUIT BOARD TO MOUNTING BRACKET.  
 14. REMOVE THE LOCKING NUTS AND FLAT WASHERS HOLDING CIRCUIT BOARD LEADS TO TERMINAL STRIP. DISCONNECT LEADS AND REMOVE CIRCUIT BOARD.  
 NOTE: IF CIRCUIT BOARD IS SPACED, LEADS MUST BE DISCONNECTED FROM OLD BOARD AND SOLDED TO REPLACEMENT UNIT.



17. REMOVE THE NUT, LOCK WASHER, AND FLAT WASHER ATTACHING CAPACITOR TO MOUNTING BRACKET. REMOVE NUT, LOCK WASHER, AND FLAT WASHER ATTACHING CAPACITOR TO MOUNTING BRACKET. REMOVE NUT, LOCK WASHER, AND FLAT WASHER ATTACHING CAPACITOR TO MOUNTING BRACKET.

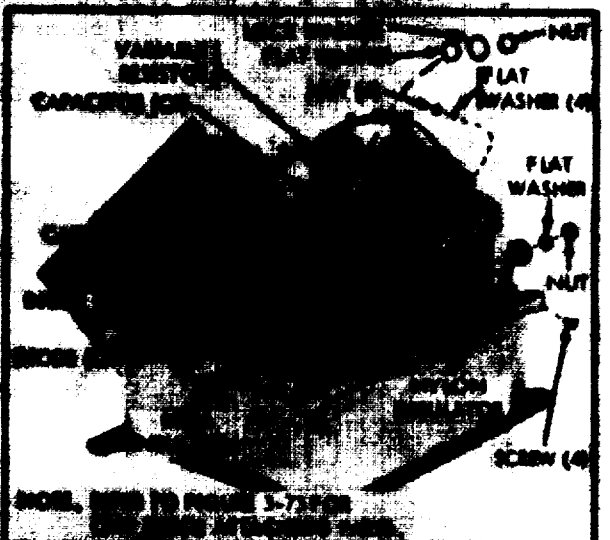

19. REMOVE THE NUT, LOCK WASHER, AND FLAT WASHER ATTACHING CAPACITOR TO MOUNTING BRACKET. REMOVE NUT, LOCK WASHER, AND FLAT WASHER ATTACHING CAPACITOR TO MOUNTING BRACKET. REMOVE NUT, LOCK WASHER, AND FLAT WASHER ATTACHING CAPACITOR TO MOUNTING BRACKET.

TA 014827

Figure 3-76. Disassembly/assembly - voltage regulator (2 of 2).

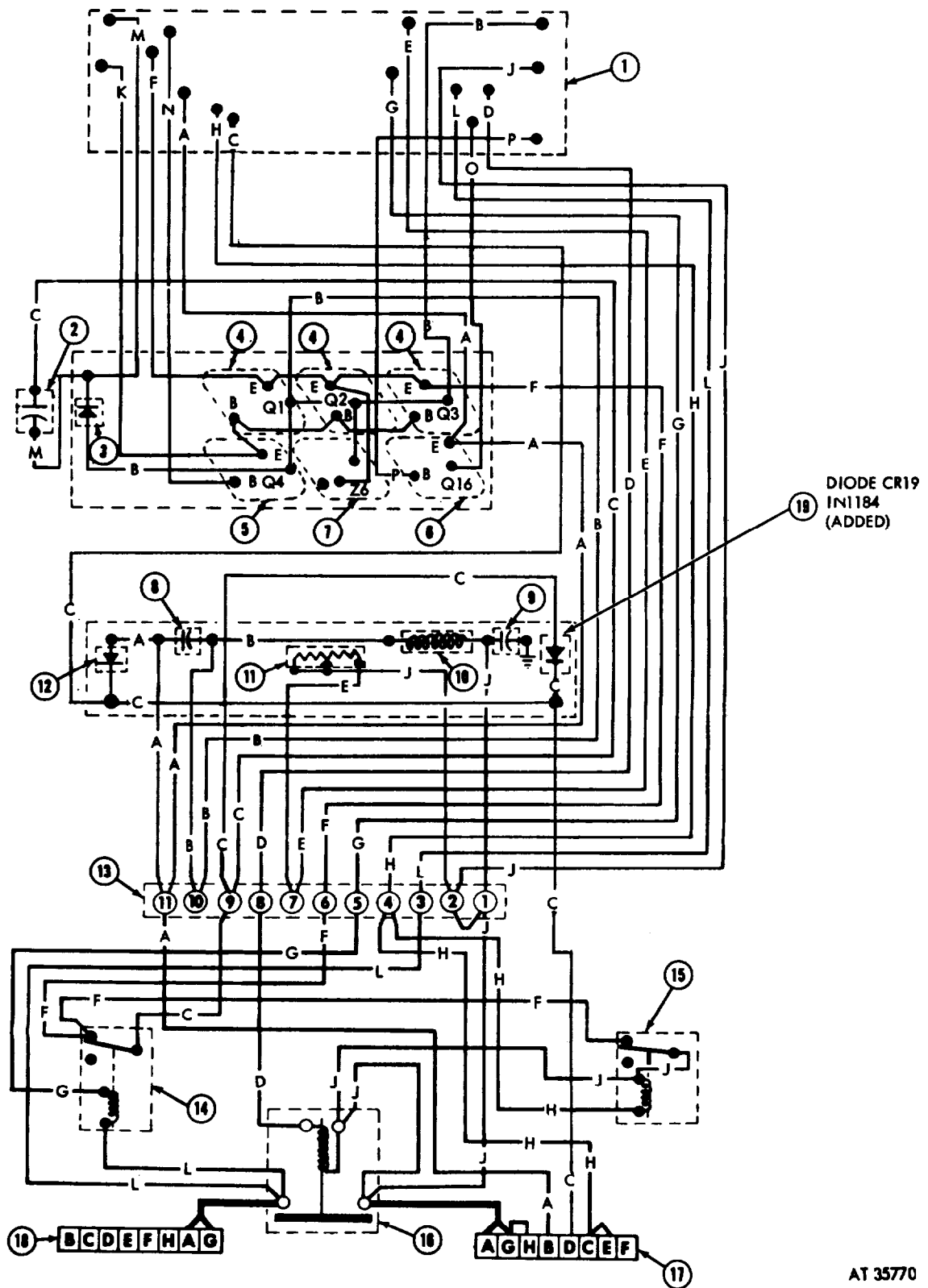

Figure 3-77. Generator regulator wiring diagram.

AT 35770

Table 3-8. Voltage Regulator Component and Wire Color Code (see figs. 3-77, 3-80)

Reference no.	Component
1	Circuit Board
2	Capacitor (C6)
3	Diode (CR2)
4	Output Power Transistor (Q1, Q2, Q3)
5	Driver Transistor (Q4)
6	Main Contactor Power Transistor (Q16)
7	Zener Diode (Z6)
8	Capacitor (C7)
9	Capacitor (C8)
10	Choke Coil
11	Voltage Adjustment Rheostat
12	Diode (CR1)
13	Terminal Strip
14	Failsafe Relay (K3)
15	Field Buildup Relay (K2)
16	Main Contactor (K1)
17	Generator Receptacle
18	Battery Receptacle
19	Diode (CR19)

Matched set

Reference Letter	Wire color
A	Black
B	Yellow
C	Blue
D	Orange
E	Purple
F	White
G	Brown
H	Gray
J	Red
K	Green
L	Red/White
M	Yellow/White
N	Green/White
O	Orange/White
P	Blue/White

e. Testing Regulator.

(1) General. Prior to conducting any bench testing, regulator should be visually inspected by removing upper half of regulator case and inspecting all wiring, bolted and soldered connections, for breaks, looseness, and poor connections. Manually check to determine if relay contacts are fused. Inspect components for signs of overheating.

**NOTE**

Printed circuit board normally has dark or brown areas near resistors. Replace any failed component prior to testing regulator.

(2) Voltage Regulator Performance Specifications. Refer to table 3-9.

(3) Bench Test Precautions (table 3-10).

(a) Only a known good 28-volt, 300-ampere DC generator (Ord. No. 8717421 or equivalent) can be used to test this regulator. Before connecting regulator make certain that generator is rotating in proper direction and that field is proper polarity. If generator polarity is in doubt, momentarily connect a 12-volt bat-

tery across generator field; battery positive to generator shunt field terminal, and battery negative to generator ground terminal.

(b) Refer to figure 3-74 and make certain that regulator is connected to generator and test stand correctly. Note that this regulator requires a ground wire (12 GA) from pin B of generator receptacle to generator ground terminal. The regulator case is not circuit ground but grounded for radio noise suppression only. Do not operate regulator with battery disconnected unless it is established that regulator is not faulty since battery is necessary for proper failsafe circuit operation.

(c) Read test procedures carefully and follow them exactly or damage to regulator and/or test stand may result. When taking voltmeter readings with regulator operating, be careful not to short adjacent terminals.

(d) Never start test stand with regulator connected, unless stand is adjusted to rotate generator at lowest possible speed. All tests are to be conducted by observing generator voltage rise while generator speed is slowly increased. If regulator is suspected to be faulty, generator speed should never be over 1,000 rpm initially or it may be impossible to observe operation of relays. Certain component failures in regulator will allow high generator voltage at medium generator speed. Never raise generator speed allowing voltage to exceed 35 volts, except for very short periods to 40 volts or unit will be damaged further. Once it is established that regulator is operating properly, generator speed may be raised to 8000 rpm.

(4) Testing Solid State Components.

(a) The solid state components used in this voltage regulator are of five types: transistors, diodes, zener diodes, capacitors, and resistors. Simple tests may be performed on these units which will disclose majority of failures.

(b) The unite must be removed from circuitry before checking (figs. 3-75 and 3-76). The transistors, diodes, and zener diodes are insulated from regulator chassis by mica washers. During removal, care must be taken not to damage washers. If they are cracked or frayed, they must be replaced. Do not apply excess heat when unsoldering wires since components can be damaged.

(c) Figure 3-78 shows the various tests. Use an ohmmeter set on RX 1 scale. No specific readings are given; only "high" and "low." High readings will generally be over 200 ohms and low readings below 10 ohms. Note that these tests are go and no-go only. If readings obtained are doubtful, or operation of the completed unit is not satisfactory, replace components to determine whether they are faulty.

(d) The transistors illustrated are the NPN type used in the regulator. Ohmmeter polarity marks are

shown but are not necessary since the test leads are reversed during each transistor test giving opposite readings.

Table 3-9. Voltage Regulator Performance Specifications

Item	Specification
1. Main contactor closing voltage.	Main contactor must close when generator voltage exceeds battery voltage by 0 to 1.2 volts. Battery voltage should be 24 volts minimum.
2. Main contactor opening reverse current.	Main contactor must open upon generator shutdown when generator interpole voltage rises to 0.15 to 0.30 volts (measured at regulator terminals). This is equivalent to 30 to 70 amperes reverse current.
3. Voltage adjustment range.	Generator voltage must be adjustable between 26 and 30 volts at generator speeds of 2500 rpm to 8000 rpm and loads of 0 to 300 amperes. At no time should voltage be adjustable to over 31.5 volts.
4. Voltage regulation.	With voltage adjusted to 28.0 volts at 2000 generator rpm, voltage measured at regulator terminals must remain between 27.5 and 28.5 volts from 2000 rpm to 8000 rpm generator speed and 0 to 300 amperes at 2000 rpm to 8000 rpm, voltage must stabilize in 0.1 second.
5. Current limit.	Generator regulator must limit generator output current by decreasing output voltage. Generator interpole voltage measured at regulator must not exceed -1.58 to - 1.92 volts upon application of increasing load current. This is equivalent to a load current not exceeding

Table 3-9. Voltage Regulator Performance Specifications - Continued

Item	Specification
6. Minimum effective resistance.	325 to 450 amperes. Effective resistance of regulator must not exceed 0.5 ohms. This is equivalent to a S-volt drop across pins A and D of regulator generator receptacle with a 10-ampere field current.
7. Main contactor voltage drop.	Voltage drop across main contactor terminals must not exceed 0.175 volts with a 200 ampere load current.
8. Failsafe circuit.	Voltage regulator must "lockout" by opening failsafe relay (K <sub>1</sub> ) and main contactor (K <sub>2</sub> ) under the following conditions: <ol style="list-style-type: none"> <li>1. Open ground connection.</li> <li>2. Simulated assembly malfunction - generator field terminal shorted to generator positive terminal.</li> </ol> When above faults are corrected, regulator shall operate normally after battery is momentarily disconnected with generator shut-down. Voltage regulator main contactor must open under following conditions: <ol style="list-style-type: none"> <li>1. Open shunt field connection.</li> <li>2. Open interpole (series field) connection.</li> </ol> Regulator must operate properly when open wires are reconnected.

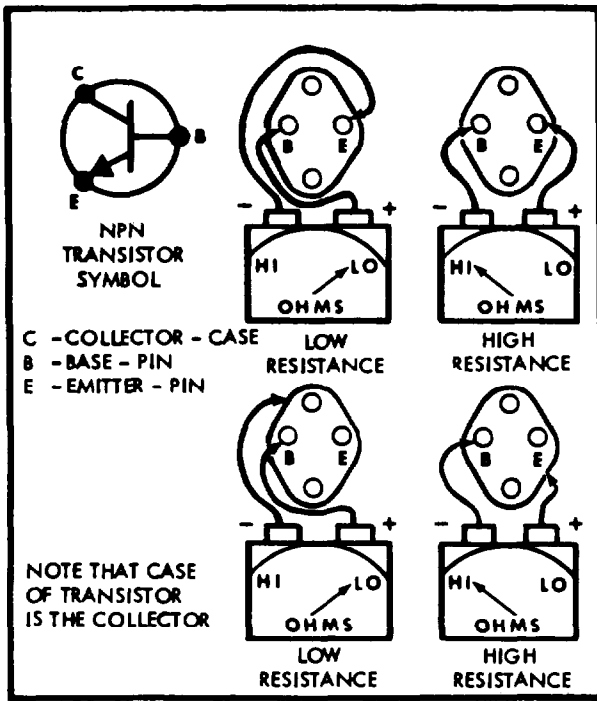

TRANSISTOR TEST

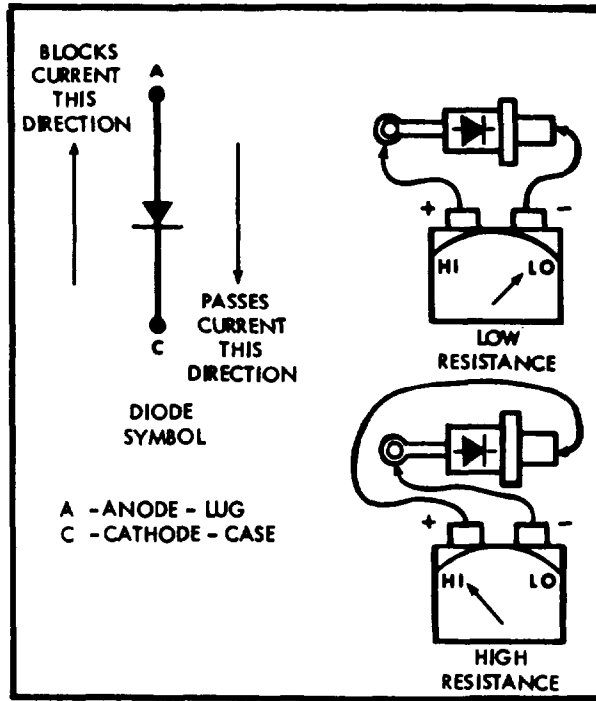

DIODE TEST

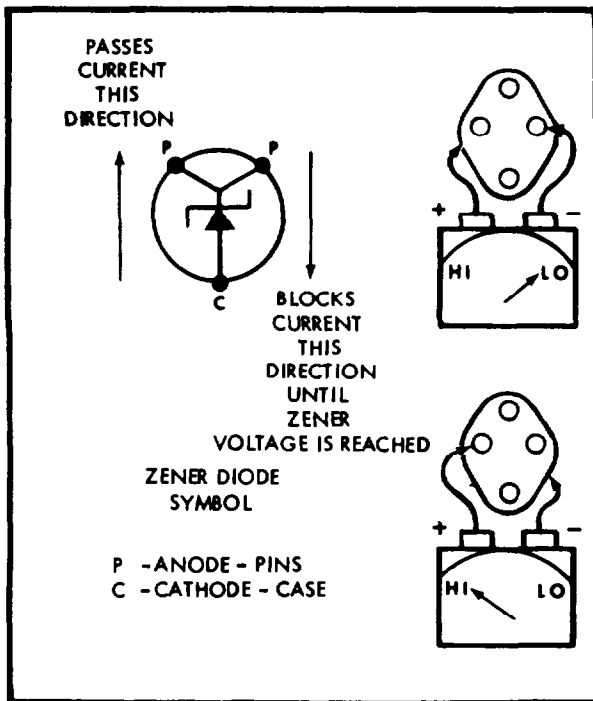

ZENER DIODE TEST

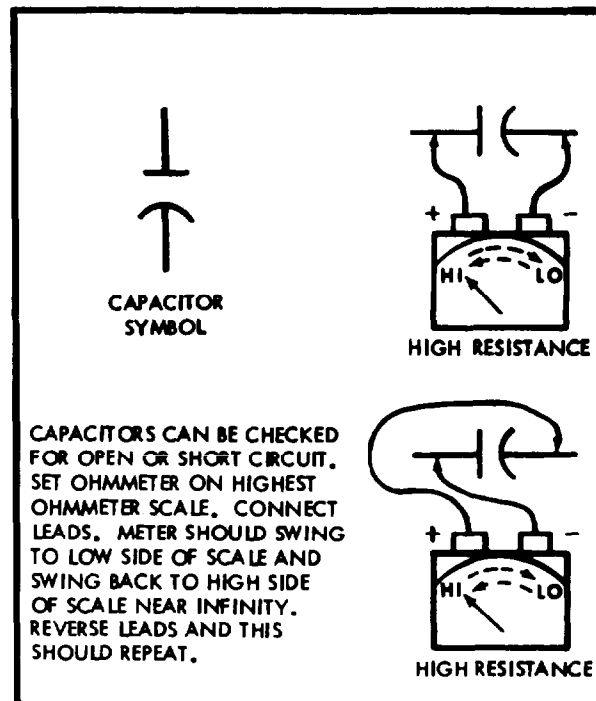

CAPACITOR TEST

ORD E70509A

Figure 3-78. Testing generator regulator transistors, diodes, and capacitors.

Table 3-10. Testing Generator Regulator

Condition	Probable causes	Corrective action
<p>1. Generator voltage does not build up past 1 or 2 volts.</p>	<p>a. Regulator locked out.</p> <p>b. Wiring faulty or CR19 diode open.</p> <p>c. Field buildup relay (K2) faulty.</p> <p>d. Failsafe relay (K3) faulty.</p>	<p>a. Momentarily disconnect positive or negative battery cable to reset failsafe circuit.</p> <p>b. Disconnect harness at regulator (figs. 3-77 and 3-80). Check resistance between generator receptacle pins A and D. Reverse instrument probes (resistance should be high in one direction and low in other). If resistance is low in both directions, CR19 diode is shorted and must be replaced. If resistance is high in both directions, trace defect to either CR19 diode or faulty wiring and replace diode or remedy faulty wiring.</p> <p>c. With regulator disconnected, apply voltage between pins A and C of generator receptacle, pin A positive. Relay should open between 10 and 14 volts. Coil resistance is 450 to 500 ohms. Replace relay if faulty.</p> <p>d. With regulator disconnected, apply voltage between pin A of battery receptacle and terminal 5 of terminal strip, pin A positive. Relay should open between 10 and 14 volts. Coil resistance is 450 to 500 ohms. Replace relay if faulty.</p>
<p>2. Generator voltage does not build up past 12 to 16 volts. Field buildup (K2) cycles.</p>	<p>a. Output power transistors Q1, Q2, Q3 or driver transistors Q4 open.</p> <p>b. Circuit board faulty.</p> <p>c. CR2 diode shorted or C6 capacitor faulty.</p>	<p>a. With generator operating at 1000 rpm and regulator connected, check voltage from green/white wire (driver transistor base to terminal 6 on circuit board). If voltage is 1/2 to 2 volts, transistors are faulty and must be replaced.</p> <p>b. If above voltage is less than 1/2 volt, circuit board is faulty and must be replaced.</p> <p>c. If above components pass check, replace CR2 diode and C6 capacitor. C6 capacitor should be 5 microfarads plus/minus 20%.</p>
<p>3. Voltage regulator locks out when generator voltage reaches 10-16 volts.</p>	<p>a. Wiring faulty.</p> <p>b. Circuit board faulty.</p>	<p>a. With regulator disconnected, refer to wiring diagram (figs. 3-77 and 3-80). Check for continuity between pin B of generator receptacle and black wire on printed circuit board. Resistance should be zero ohms. Replace faulty wiring.</p> <p>b. If wiring is good and regulator still locks out at 10-16 volts, printed circuit board is faulty and must be replaced.</p>
<p>4. Regulator locks out when generator voltage reaches 24 to 28 volts.</p>	<p>a. Field buildup relay K2 faulty.</p> <p>b. Output transistors Q1, Q2, Q3, zener diode Z6, or drive transistor Q4 is shorted.</p>	<p>a. Refer to item 1c.</p> <p>b. Adjust generator speed for 20 volts output (approx. 1000 rpm). Check voltage across terminals 10 and 6 of terminal strip, 10 positive. If voltage is between 0 and 1/2 volt, an output transistor or zener diode is shorted. If voltage is between 1/2 and 1 1/2 volts, driver transistor is shorted. To verify that transistors are shorted, check resistance between terminals 10 and 6 of terminal strip with regulator disconnected and field buildup relay (K2) held open. Check resistance in both directions by reversing instrument probes. If resistance is low in both directions, one or more components are</p>

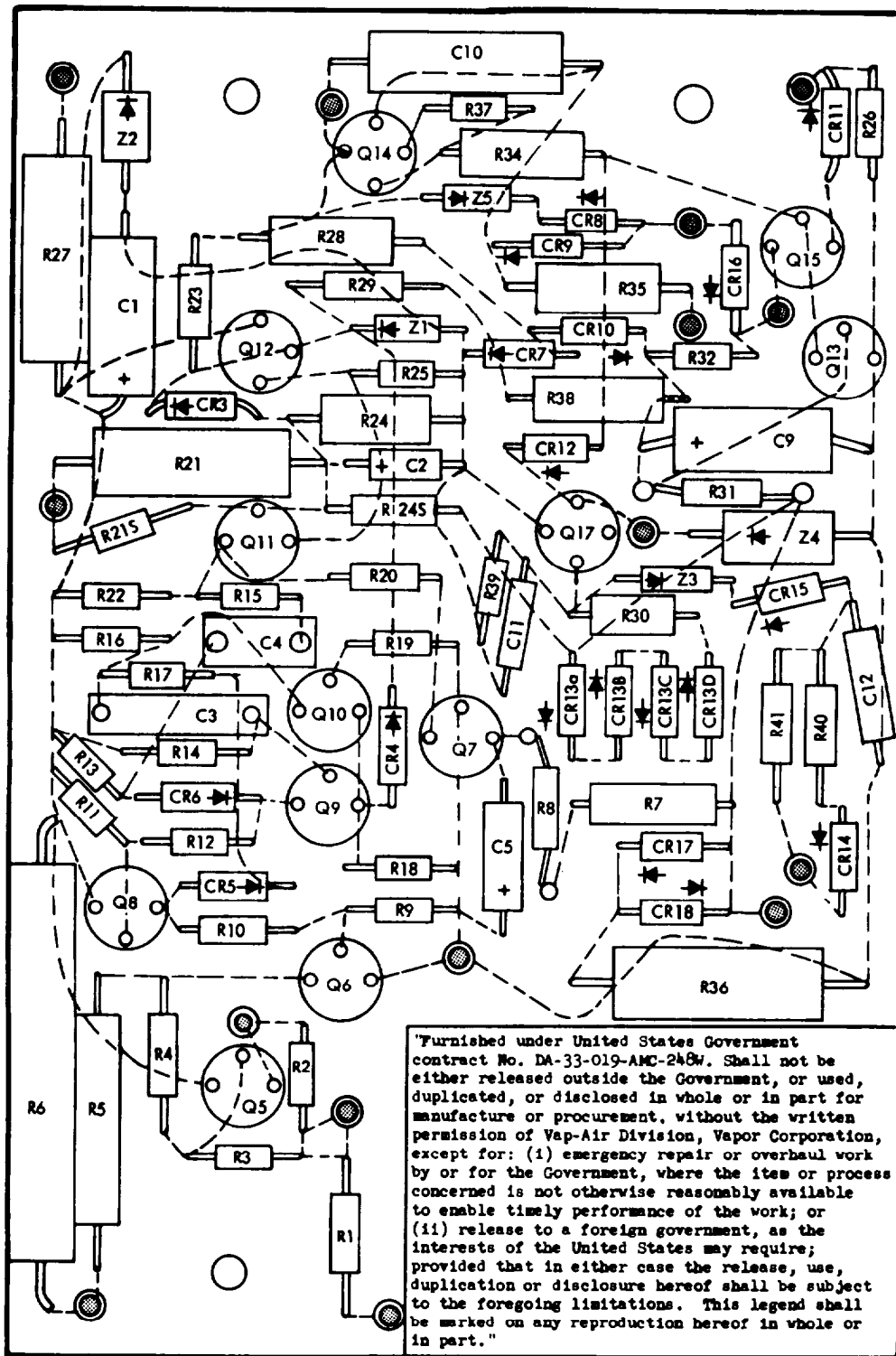

Table 3-10. Testing Generator Regulator - Continued

Condition	Probable causes	Corrective action
5. Generator voltage regulates at 30 to 31 volts and is not adjustable.	<ul style="list-style-type: none"> <li>c. Circuit board faulty.</li> <li>d. Capacitor (C6) shorted.</li> </ul> <p>Voltage adjustment rheostat is faulty.</p>	<p>shorted. If one or more transistors are faulty, all must be replaced. Zener diode must be checked separately to determine if it must be replaced (fig. 3-77).</p> <ul style="list-style-type: none"> <li>c. If voltage measured across terminals 10 and 6 of terminal strip is 1 1/2 to 8 volts, circuit board is faulty and must be replaced.</li> <li>d. Check capacitor (C6) (fig. 3-77). Replace if faulty.</li> </ul> <p>With regulator disconnected, check resistance between terminals 2 and 7 on terminal strip. Resistance should vary between near 0 to 100 ohms as rheostat is rotated. Replace if rheostat is found faulty or readings are erratic.</p>
6. Generator voltage regulates at approx. 35 volts. Failure relay (KS) cycles.	<ul style="list-style-type: none"> <li>a. Voltage adjustment rheostat is faulty.</li> <li>b. Circuit board faulty.</li> </ul>	<ul style="list-style-type: none"> <li>a. Refer to item 5.</li> <li>b. If rheostat checks out satisfactorily, circuit board is faulty and must be replaced.</li> </ul>
7. Generator voltage goes above 35 volts and no relays cycle, regulator does not lockout.	<ul style="list-style-type: none"> <li>a. Battery disconnected.</li> <li>b. Poor connections.</li> <li>c. Failsafe relay (K3) faulty.</li> <li>d. Circuit board faulty.</li> </ul>	<ul style="list-style-type: none"> <li>a. Connect battery in circuit.</li> <li>b. Refer to wiring diagrams and check continuity of all circuits (fig. 3-77, 3-80).</li> <li>c. Refer to item 1d.</li> <li>d. If above components check satisfactory, circuit board is faulty and must be replaced.</li> </ul>
8. Generator Voltage fluctuates greatly.	<ul style="list-style-type: none"> <li>a. Voltage adjustment rheostat faulty.</li> <li>b. Poor connections.</li> <li>c. Output power transistors (Q1, Q2, Q3) faulty.</li> </ul>	<ul style="list-style-type: none"> <li>a. Refer to item 5.</li> <li>b. Refer to wiring diagram and check continuity of all circuits (figs 3-77, 3-80).</li> <li>c. Replace driver and power transistors if above components check out satisfactorily.</li> </ul>
9. Main contactor(K1)does not close when generator voltage exceeds battery voltage by 0 to 1.2 volts; generator voltage regulates at 28 volts.	<ul style="list-style-type: none"> <li>a. Contactor (K1) faulty.</li> <li>b. Contactor power transistor (Q16) open.</li> <li>c. Circuit board faulty.</li> </ul>	<ul style="list-style-type: none"> <li>a. With regulator disconnected, apply voltage between generator receptacle, pin A and terminal 8 on terminal strip, pin A positive. Contactor should close between 8 and 12 volts. Coil resistance should be approx. 70 ohms. Replace contactor if faulty.</li> <li>b. With regulator connected and operating at 28 volts, check voltage from terminal 8 to 11 on terminal strip, terminal 8 positive. If contactor power transistor is good this voltage should be 1 to 3 volts. Transistor is faulty if this voltage is 25-27 volts and the voltage from the blue/white wire (contactor transistor base) to terminal 11 is 0.7 volts.</li> <li>c. Circuit board is faulty if the voltage from the blue/white wire (contactor transistor base) to terminal 11 is zero and the contactor and contactor transistor check out satisfactorily.</li> </ul>
10. Contactor (K1) closes before generator voltage surpasses battery voltage.	<ul style="list-style-type: none"> <li>a. Contactor power transistor (Q16) shorted.</li> </ul>	<ul style="list-style-type: none"> <li>a. With regulator disconnected, check resistance between the orange/white wire (transistor collector) to terminal 11 on terminal strip. Reverse instrument probes. If resistance is low in both directions, transistor is shorted and must be replaced.</li> </ul>

Table 3-10. Testing Generator Regulator Continued

Condition	Probable causes	Corrective action
11. Contactor (K1) does not open with proper reverse current.	<ul style="list-style-type: none"> <li>b. Circuit board faulty.</li> <li>a. Contactor faulty.</li> </ul>	<ul style="list-style-type: none"> <li>b. If contactor transistor is satisfactory, circuit board is faulty and must be replaced</li> <li>a. See item 9a. Then refer to the following: With regulator operating with approx. 100 amperes reverse current (generator motoring), check voltage from terminal 1 to terminal 8, terminal 1 positive. If voltage is 0 to 2 volts, contactor is faulty and must be replaced.</li> </ul>
12. Contactor (K1) chatters during operation.	<ul style="list-style-type: none"> <li>b. Circuit board faulty.</li> <li>a Battery disconnected</li> <li>b. Wiring faulty.</li> <li>c. Circuit board faulty.</li> </ul>	<ul style="list-style-type: none"> <li>b. If voltage is 20 to 24 volts, circuit board is faulty and must be replaced.</li> <li>a Connect battery.</li> <li>b. With regulator disconnected, check resistance between pins B and C of generator receptacle. Wiring is faulty if reading is zero or infinity ohms.</li> <li>c. If above components check out satisfactorily, circuit board is faulty and must be replaced.</li> </ul>
13. Current limit setting too high or low.	Circuit board faulty.	Replace circuit board.
14. Regulator generates excessive radio noise during operation.	Capacitors C7 or C8 faulty.	Check capacitors and replace if faulty. C7 should be 10 microfarads plus/minus 20%. C8 should be 1 microfarads plus/minus 20%.



ORD E70558

Figure 3-79. Generator regulator circuit board diagram.

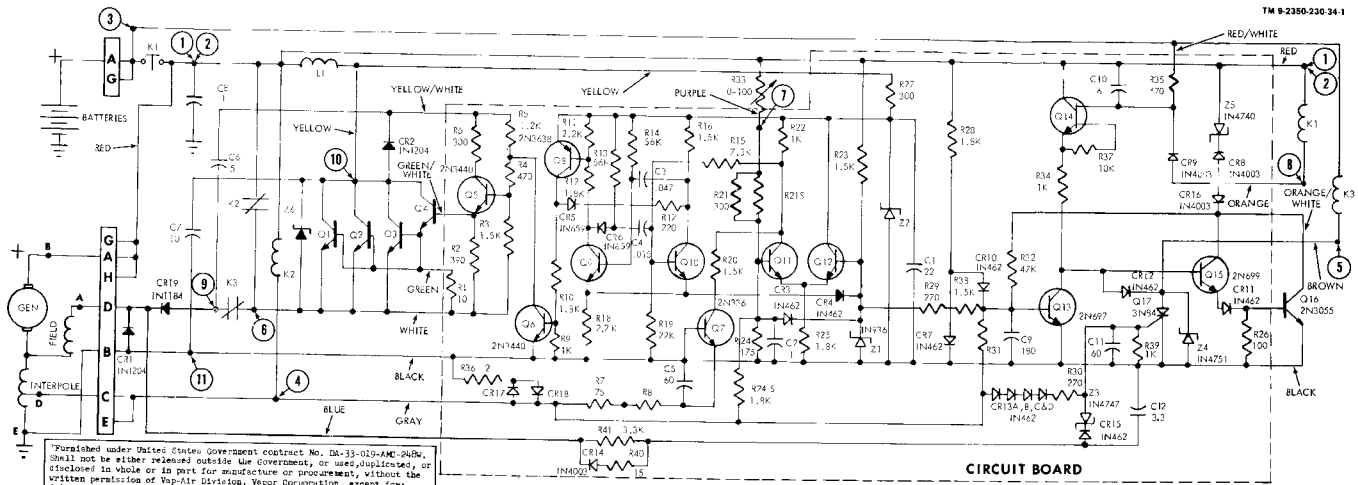

"Furnished under United States Government contract No. DA-33-019-AMC-2484. Shall not be either released outside the Government, or used, duplicated, or disclosed in whole or in part for manufacture or procurement, without the written permission of Vep-Air Division, Vepor Corporation, except for: (i) emergency repair or overhaul work by or for the government, where the item or process concerned is not otherwise reasonably available; (ii) timely performance of the work; or (iii) release to a foreign government, as the interests of the United States may require; provided that in either case the release, use, duplication or disclosure hereof shall be subject to the foregoing limitations. This legend shall be marked on any reproduction hereof in whole or in part."

Figure 2-88 Generator regulator system - schematic diagram.

NOTE. ○ DENOTES TERMINAL STRIP NUMBER.

**Section VI. REPAIR OF TRACKS AND SUSPENSION COMPONENTS**

**3-35. Scope**

This chapter illustrates and describes repair procedures for components of the suspension system listed in table 3-11.

*Table 3-11. Suspension System Components*

Component	Figure reference	
	Disassembly/assembly	Repair data
Road wheel arm upper spindle housing	3-81	
Idler wheel hub housing	3-82	
Track hydraulic adjuster	3-83	3-83
Road wheel arm assy (Positions 1, 4, 5) -		3-84

*Table 3-11. Suspension System Components - Continued*

Component	Figure Reference	
	Disassembly/assembly	Repair data
Road wheel arm assy (Positions 2,3)		3-85
Track adjuster idler assy		3-86
Track drive sprocket assy		3-87
Shock absorber (Bearings)	3-88	

**3-36. Detailed References**

a. For removal and installation procedures for suspension components, refer to TM 9-2350-230-20-1.

b. For repair of track, refer to TM 9-2350-230-20-1.

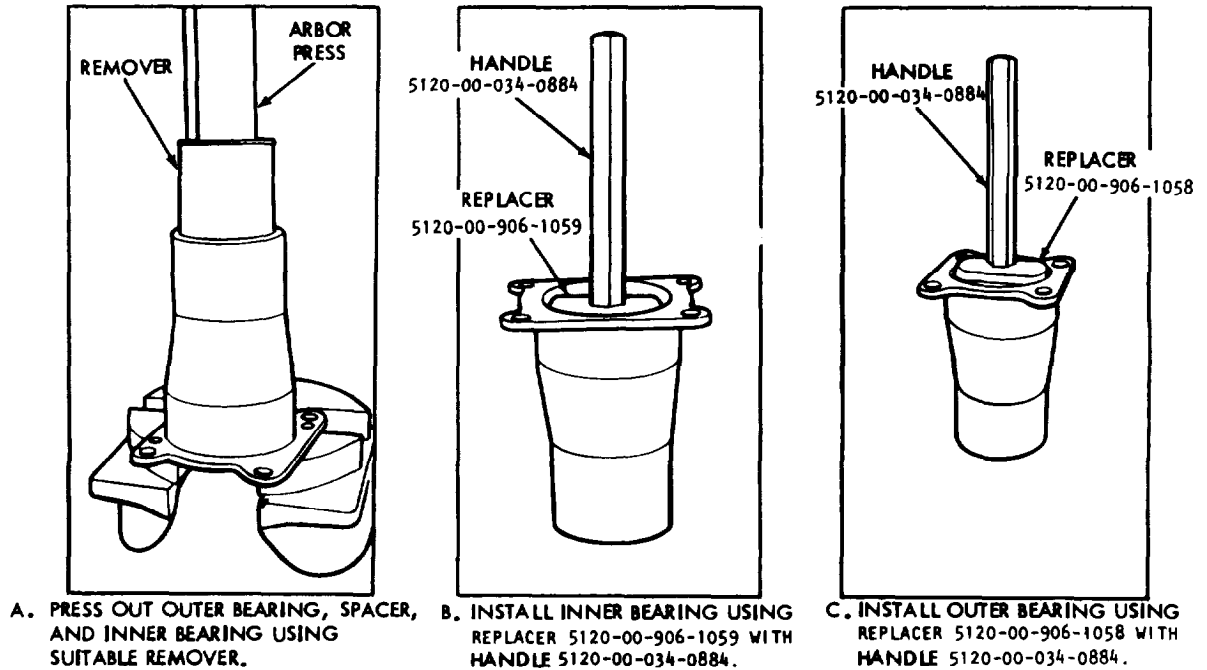
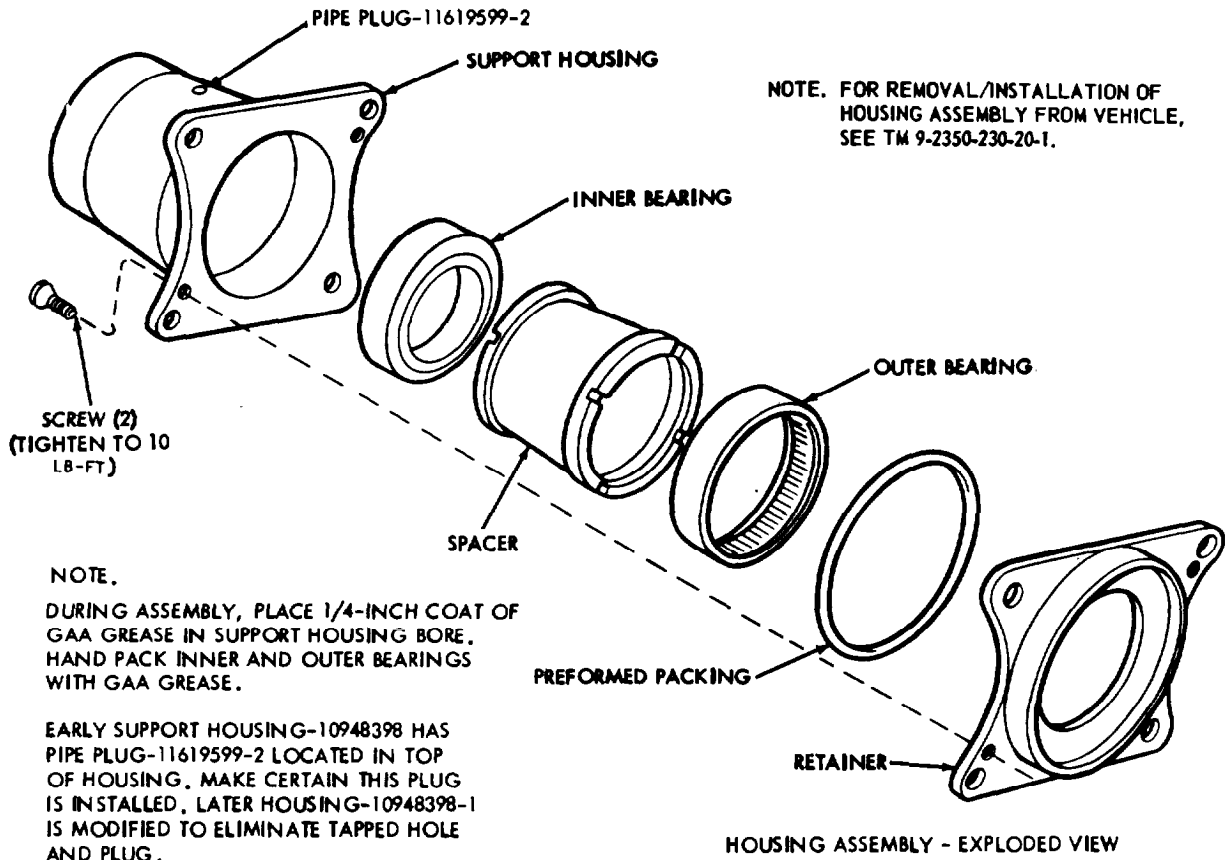
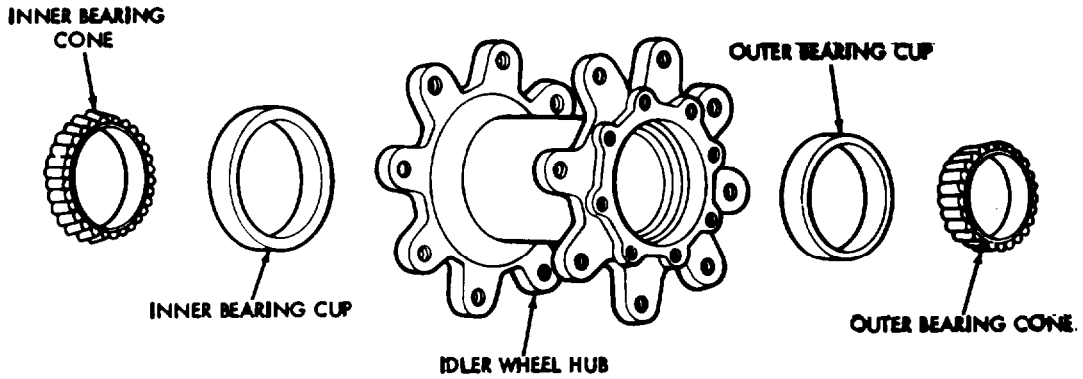
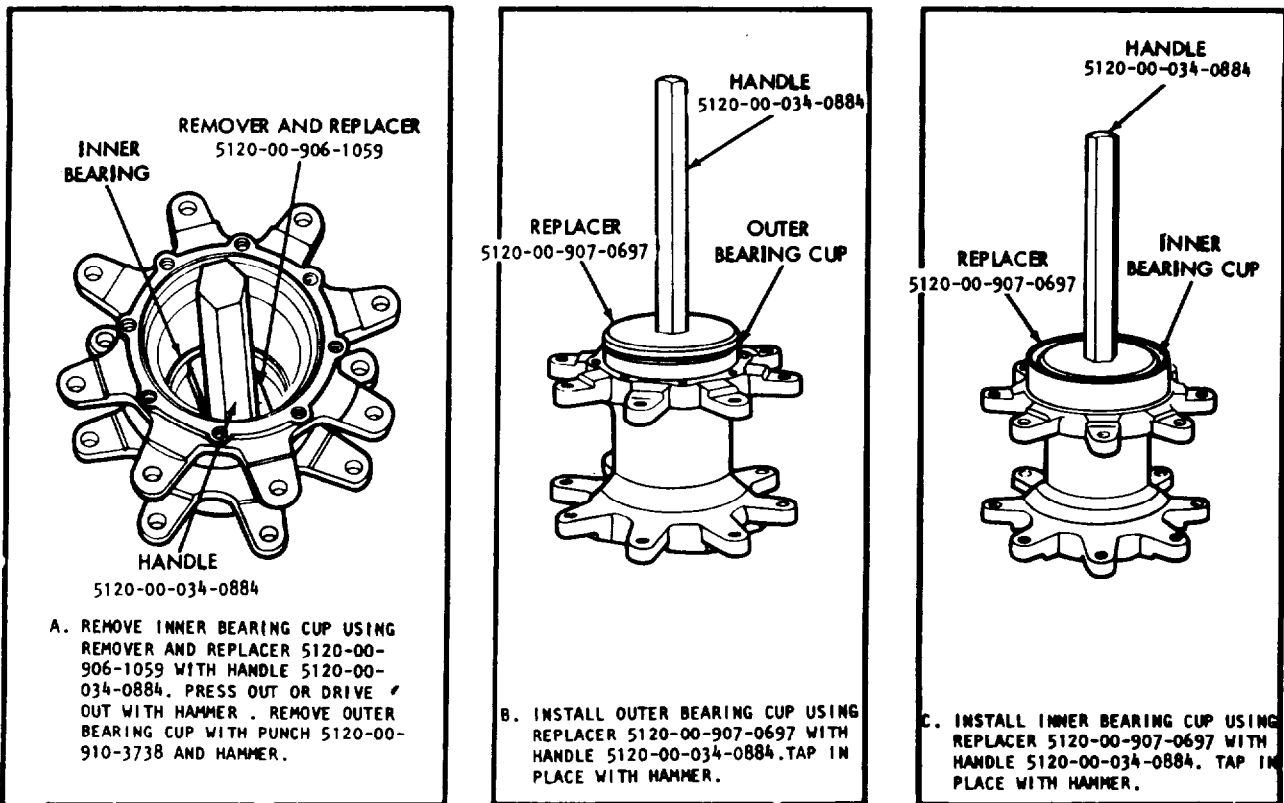

Figure 3-81. Disassembly/assembly - roadwheel arm support housing - positions 1, 4, and 5.



NOTE. DURING ASSEMBLY, APPLY 1/4-INCH COAT OF GAA GREASE IN IDLER WHEEL HUB BORE. HAND PACK INNER AND OUTER BEARINGS WITH 1/4-INCH COAT OF GAA GREASE.

IDLER WHEEL HUB ASSEMBLY - EXPLODED VIEW.



TA 014796

Figure 3-82. Disassembly/assembly - idler wheel hub.

DISASSEMBLY NOTE: REMOVE FITTING (4) OR PLUG (5) AND PULL PISTON FROM CYLINDER. IF NECESSARY, USE LUBRICATION GUN AND INJECT GREASE TO FORCE PISTON FROM CYLINDER.

ASSEMBLY NOTE: STAKE BEARINGS IN 3 PLACES ON BOTH SIDES. GREASE CYLINDER INSIDE DIAMETER AND PISTON OUTSIDE DIAMETER WITH GAA AND SLIDE COMPONENTS TOGETHER. TIGHTEN PLUG AND FITTINGS (ITEMS 3.1, 4 AND 5) TO 18 LB-FT. AND INJECT GAA GREASE INTO FITTING 3.1 USING LUBRICATION GUN.

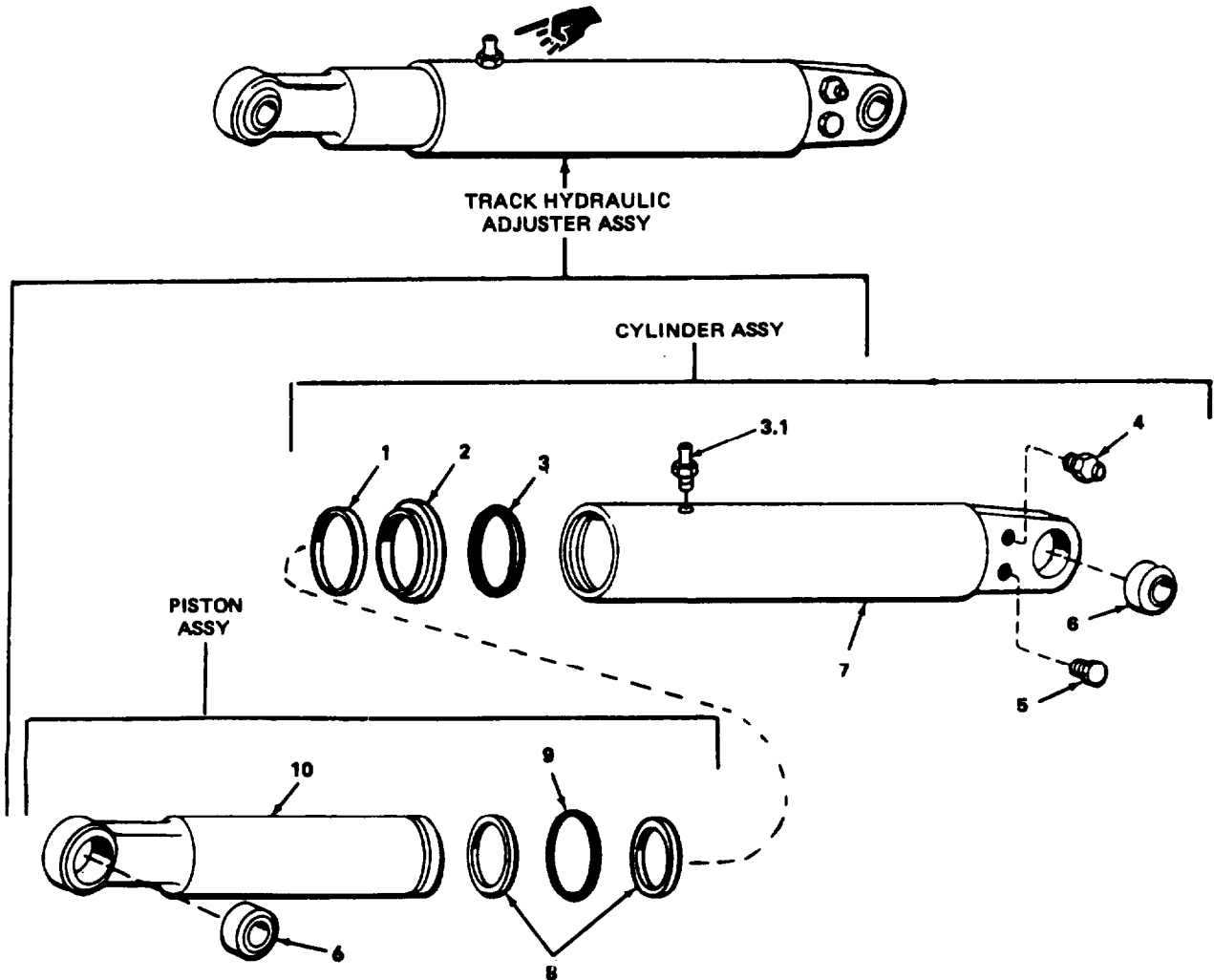

TA178479

Figure 3-83. Disassembly/assembly - track hydraulic adjuster and repair data.



Table 3-12. Disassembly/Assembly - Track Hydraulic Adjuster and Repair Data - see fig 3-83)

Reference no.	Inspection data and points of measurement	Size and fit of new parts	Field repair limit
1	Retaining Ring - 10875429 Replace if damaged or defective.		
2	Scraper - MS28776-21 Replace if damaged or defective.		
3	Preformed Packing - MS28775-136 Replace.		
4	Fitting - MS15003-1 Replace if damaged or defective.		
5	Plug-444613 Replace if threads are stripped or damaged.		
6	Bearing - AN942-10 OD ID Replace if radial wear exceeds .010.	1.5620 - 1.5625 0.6245 - 0.6250	*
7	Cylinder - 10948740 Diameter of bore for end bearing Fit of bearing in bore	1.5605 - 1.5620 0.0000 - 0.0020T	*
8	Retainer - 11593720 Replace if defective.		
9	Preformed Packing- MS28775-326 Replace.		
10	Piston - 10948748 Diameter of bore for bearing Fit of bearing to bore Note. Items 1,2,3,8, and 9 are supplied in parts kit - 5702928. (NSN 2530-00-919-6456)	1.5620 - 1.5605 0.0000 - 0.0020T	

Note. See paragraph 2-12 on repair limits marked \*\*, T, or L.

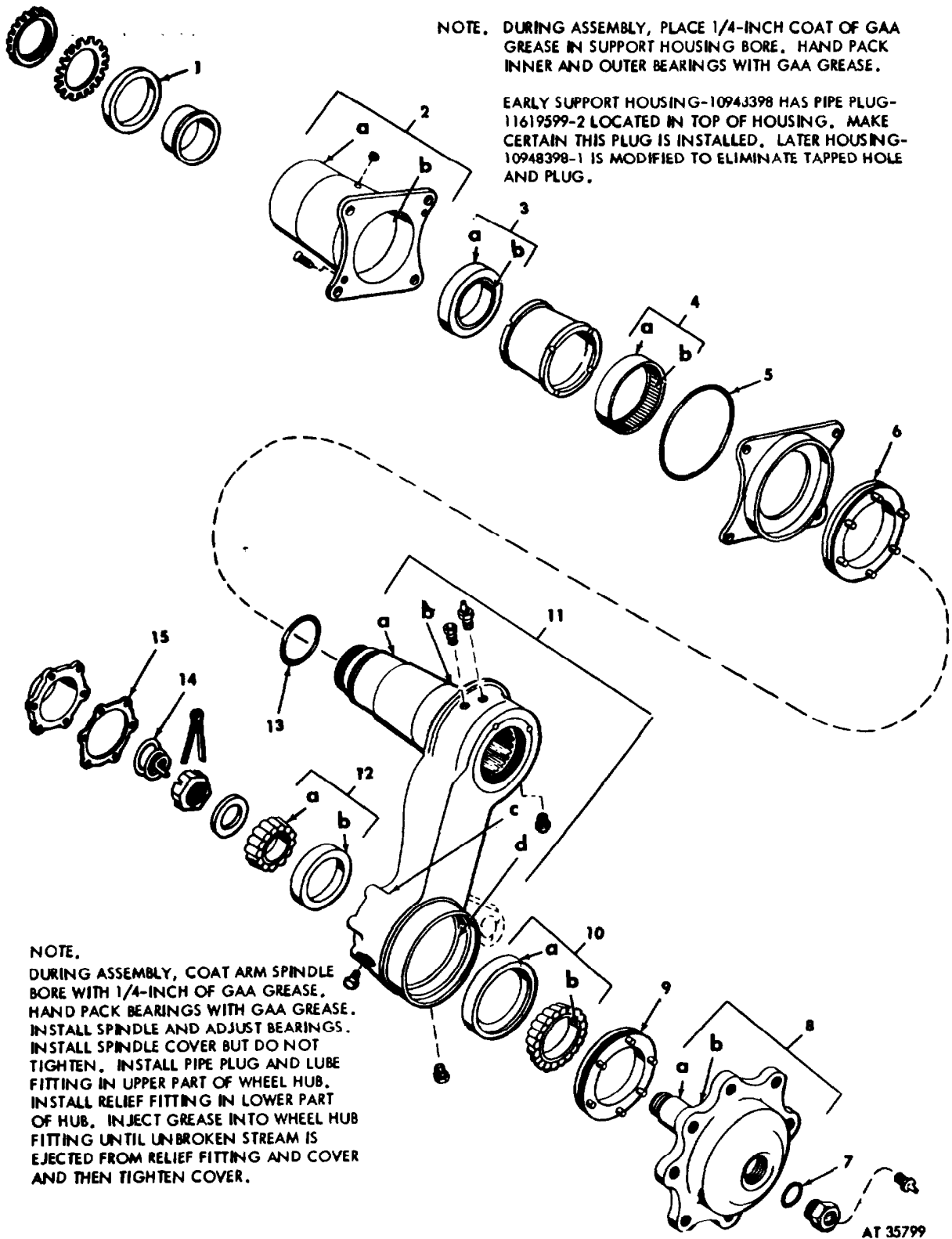

Figure 3-84. Roadwheel arm assembly - positions 1, 4, and 5 - repair data

Table 3-13. Roadwheel Arm Assembly - Positions 1, 4, and 5 - Repair Data - (see fig 3-84)

Reference no.	Inspection data and points of measurement	Size and fit of new parts	Field repair limit
1	Seal - 10946878 Replace		
2	Housing - 10948398 and 10943398-1		
a	OD of Inner Bearing Bore	3.9988 - 3.9998	4.000
3a-2a	Fit of Inner Bearing to Housing	0.0012T to 0.0006L	0.0008L
b	OD of Outer Bearing Bore	4.6238 - 4.6248	4.6250
4a-2b	Fit of Outer Searing to Housing	0.0012T to 0.006L	0.0008L
3	Housing Inner Bearing - 10946881		
b	ID	3.1244 - 3.125	3.1255
a	OD	3.9992 - 4.000	3.9990
4	Housing Outer Searing - 10946880		
b	ID	4.0490 - 4.0504	4.0509
a	OD	4.6242 - 4.6250	4.6238
5	Preformed Packing - MS29513-253 Replace		
6	Seal - 10946849 Replace		
7	Preformed Packing - MS29513-129 Replace		
8	Spindle - 10954793		
	OD of Inner Bearing Journal	1.3750 - 1.3755	1.3746
12a-8a	Pit of Inner Bearing on Spindle Journal	0.0005T to 0.0005L	0.0008L
b	OD of Outer Bearing Journal	2.4988 - 2.4993	2.4984
10b-8b	Pit of Outer Bearing on Spindle Journal	0.0007L to 0.0017L	0.0019L
9	Seal - 10946850 Replace		
10	Spindle Outer Bearing - MS19081-105		
b	ID	2.5000 - 2.5005	2.5099
a	OD	4.4375 - 4.4385	4.4371
11	Arm Assy - 19948755-1 and 10948755-2		
a	OD of Housing Inner Bearing Journal	3.1298 - 3.1248	**
3b-11a	At of Inner Bearing on Journal	0.0004T to 0.0012L	0.0016L
b	OD of Housing Outer Bearing Journal	4.0473 - 4.0480	**
4b-11b	Fit of Outer Bearing on Journal	0.0024L to 0.0031L	0.0035L
c	ID of Spindle Inner Bearing Bore	2.8735 - 2.8745	**
12b-11c	Pit of Inner Bearing in Bore	0.0025T to 0.0005T	0.0003T
d	ID of Spindle Outer Bearing Bore	4.4355 - 4.4365	**
10a-11d	Fit of Outer Bearing in Bore	0.003T to 0.001T	0.0005T
12	Spindle Inner Bearing - MS19081-40		
a	ID	1.3750 - 1.3755	1.3755
b	OD	2.8750 - 2.8760	2.8748
13	Preformed Packing - MS29513-145 Replace		
14	spring - 7379067 Spring is radio suppression component; replace if defective		
15	Gasket - 10948704 Replace		

Note. See paragraph 2-12 on repair limits marked \*, \*\*, T, or L.

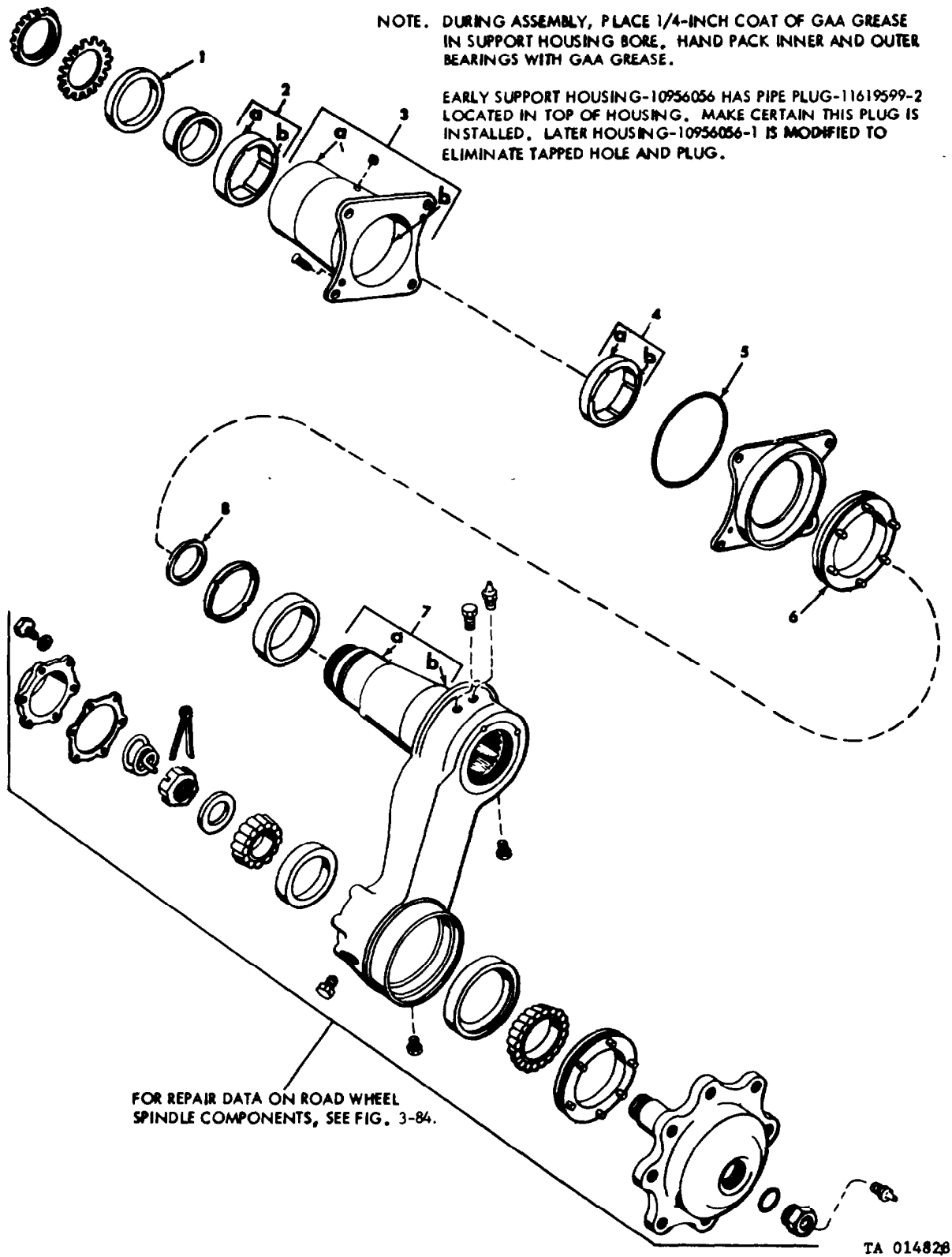
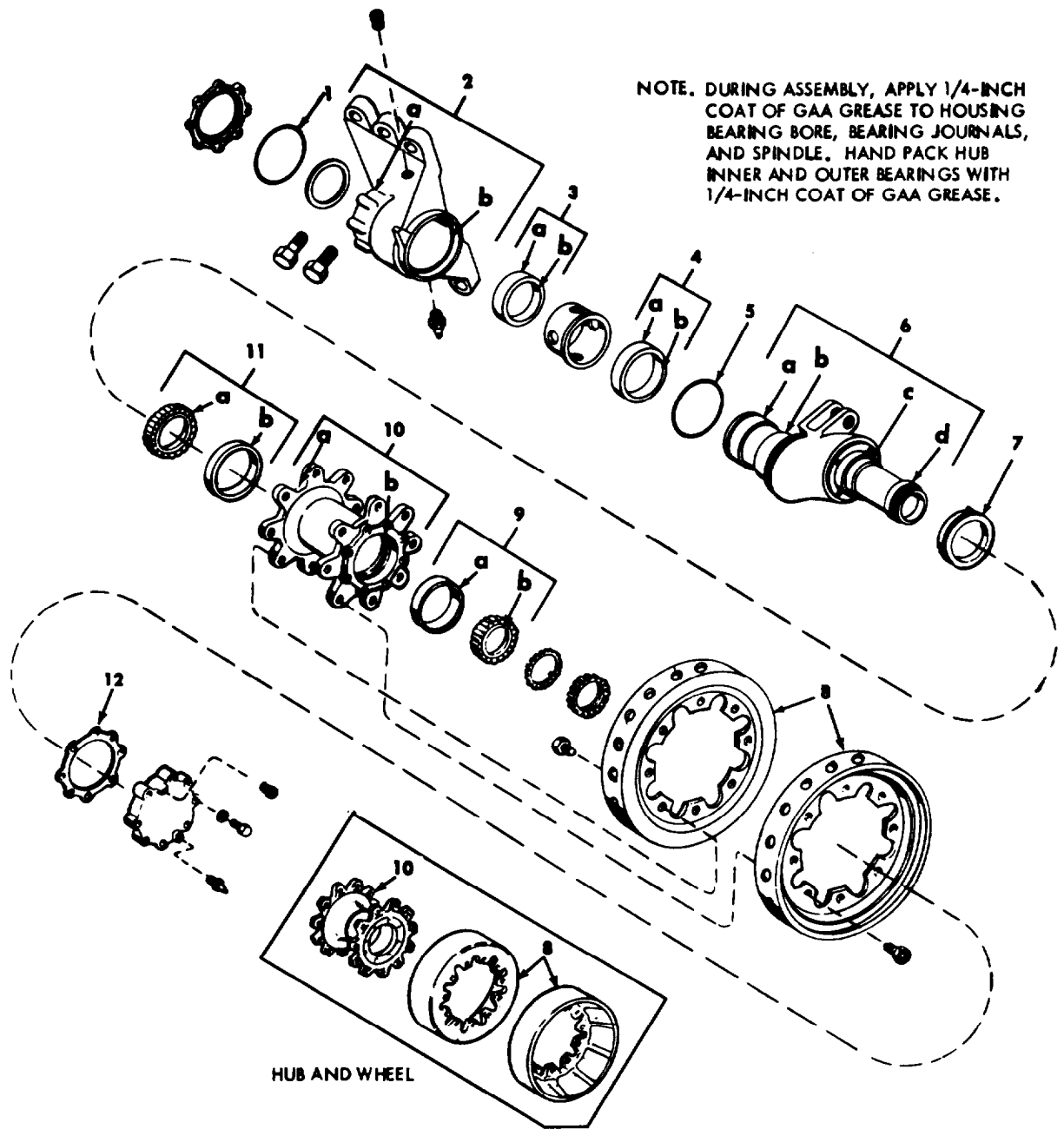

Figure 3-85. Roadwheel arm assembly - positions 2 and 3 - repair data.

Table 3-14. Roadwheel Arm Assembly - Positions 2 and 3 - Repair Data (see fig 3-86)

Reference no.	Inspection data and points of measurement	Size and fit of new parts	Field repair limit
1	Seal - 10946878 Replace		
2	Housing Inner Bearing - 10948682		
a	OD	3.624 - 3.629	3.6238
b	ID	3.124 - 3.133	3.1334
3	Support Housing - 10956056		
a	Diameter of Inner Bearing Bore	3.621 - 3.622	3.6225
2a-3a	Fit of Inner Bearing to Bore	0.008T to 0.002T	0.0005T
b	Diameter of Outer Bearing Bore	3.996 - 3.997	3.999
4a-3b	Fit of Outer Bearing to Bore	0.008T to 0.002T	0.0005T
4	Housing Outer Bearing - 10956057		
a	OD	3.999 - 4.004	3.998
b	ID	3.507 - 3.516	3.517
5	Reformed Packing - MS29513-253 Replace		
6	Seal- 10946849 Replace		
7	Arm Assy - 10954286		
a	Diameter of Inner Bearing Journal	3.116 - 3.118	3.1157
2b-7a	Fit of Inner Bearing to Journal	0.015L to 0.004L	0.017L
b	Diameter of Outer Bearing Journal	3.499 - 3.501	3.498
4b-7b	Fit of Outer Bearing to Journal	0.017L to 0.006L	0.017L
8	Preformed Packing - MS29513-145 Replace		

Note. See paragraph 2-12 on repair limits marked \*,\*\*, T, or L.



AT 35801

Figure 3-86. Track hydraulic adjuster idler arm assembly - repair data.

Table 3-15. Track Adjuster Idler Arm Assembly -Repair Data (see fig 3-86)

Reference no.	Inspection data and points of measurement	Size and fit of new parts	Field repair limit
1	Preformed Packing - MS28775-244 Replace		
2	Housing - 10954636 Replace if damaged or defective		
a	Diameter of Inner Bearing Bore	4.3755 - 4.3765	**
b	Diameter of Outer Bearing Bore	4.6255 - 4.6275	**
3a-2a	Fit of Inner Bearing to Housing	.0055L to .0165L	0.020L
4a-2b	Fit of Outer Bearing to Housing	.005L to .0175L	0.020L
3	Housing Inner Bearing - 10958708		
a	OD	4.360 - 4.370	4.355
b	ID	3.495 - 3.509	3.510
4	Housing Outer Bearing - 10948706		
a	OD	4.610 - 4.620	4.608
b	ID	3.745 - 3.759	3.760
5	preformed Packing - 11593924 Replace		
6	Shaft-10954635		
a	OD of Housing Inner Bearing Journal	3.4994 - 3.5004	
3b-6a	Fit of Bearing to Journal	0.0054T to 0.0096L	0.010L
b	OD of Housing Outer Bearing Journal	3.7494 - 3.7504	
4b-6b	Fit of Bearing to Journal	0.0054T to 0.0096L	0.010L
c	OD of Hub Inner Bearing Journal	3.7488 - 3.7498	
11a-6c	Fit of Bearing to Journal	0.0002L to 0.0022L	0.0035L
d	OD of Hub Outer Bearing Journal	3.4988 - 3.4998	
9b-6d	Fit of Bearing to Journal	0.0002L to 0.0022L	0.0035L
7	Seal - 10946849 Replace		
8	Wheel - 10956256 Replace if cracked, chipped, bent or worn		
9	Hub Outer Bearing - 10946888		
a	OD	4.876 - 4.876	*
b	ID	3.500 - 3.501	*
10	Hub - 11605110		
a	Diameter of Inner Bearing Bore	5.118 - 5.120	*
b	Diameter of Outer Bearing Bore	4.868 - 4.870	*
11	Hub Inner Bearing - 7748793		
a	ID	3.760 - 3.751	*
b	OD	5.125 - 5.126	*
12	Gasket - 10948709 Replace		

Note. See paragraph 2-12 on repair limits marked \*,\*\*, T, or L.

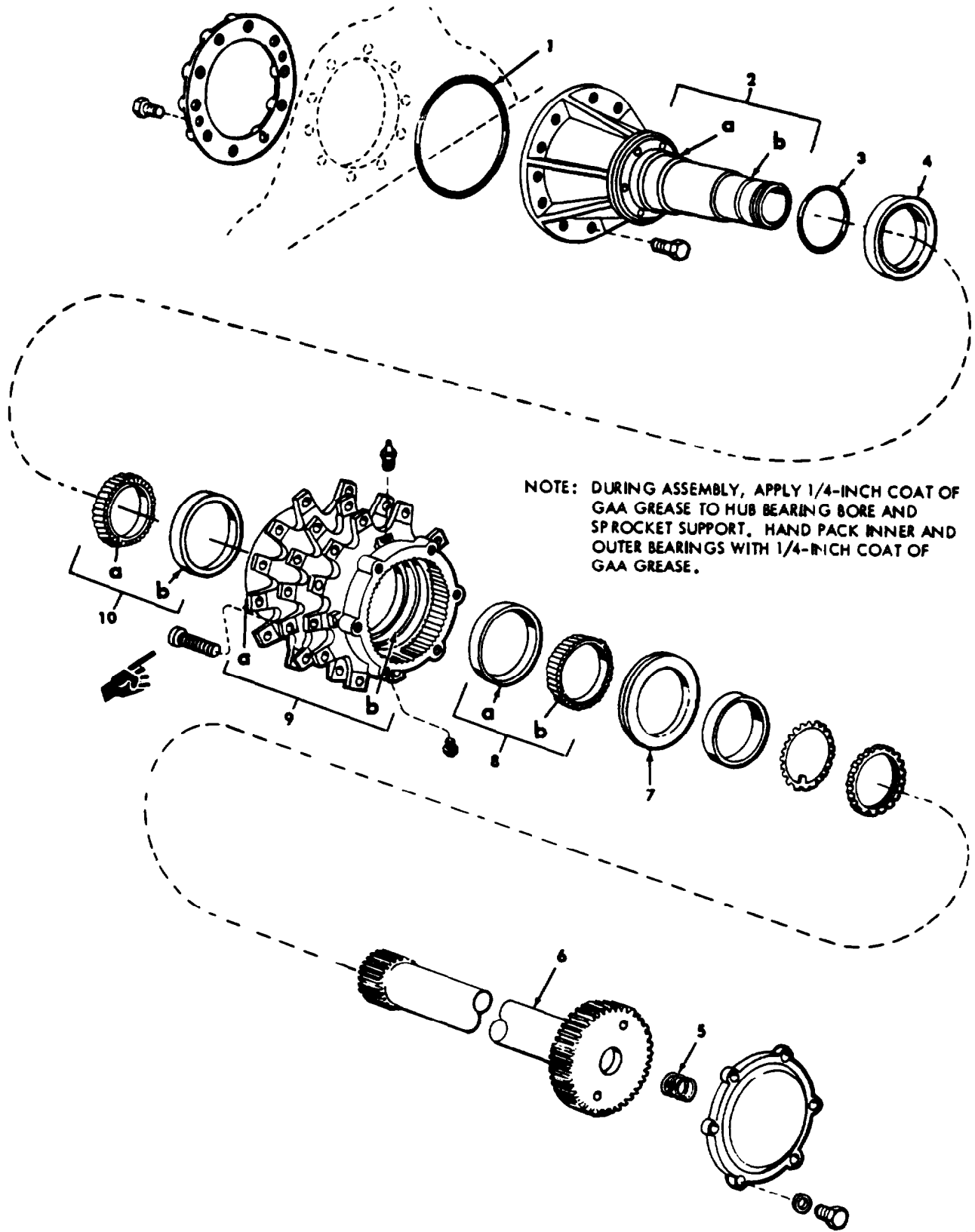

TA178480

Figure 3-87. Track drive sprocket hub and axle shaft - repair data.



Table 3-16. Track Drive Sprocket and Axle Shaft - Repair Data - (see fig 3-87)

Reference no.	Inspection data and points of measurement	Size and fit of new parts	Field repair limit
1	Preformed Packing- MS9021-258 Replace		
2	Sprocket Drive Support - 10948410		
a	OD of Inner Bearing Journal	4.2488 - 4.2498	4.248
	Fit of Inner Bearing on Journal	0.0002L - .0017L	.0020L
b	OD of Outer Bearing Journal	3.9988 - 3.9998	3.998
	Fit of Outer Bearing on Journal	0.0002L - .0022L	.0028L
3	Seal - MS-28775-240 Replace		
4	Seal - 7748649 Replace		
5	Spring - 10948393 Replace if defective		
	Free length	2.000	
	Assembled length	1.000	
6	Axle Shaft - 10948849 If splines are damaged, or shaft cracked, replace		
7	Seal - 10946857 Replace		
8	Outer Bearing - 10946894		
a	OD	5.376 - 5.376	5.3745
b	ID	4.000 - 4.001	4.0015
9	Sprocket Drive Hub - 10948412		
a	ID of Inner Bearing Bore	5.747 - 5.749	5.7495
	Fit of Inner Bearing in Bore	.004T to .001T	.0003T
b	ID of Outer Bearing Bore	5.372 - 5.374	5.3745
	Fit of Outer Bearing in Bore	.004T to .001T	.0003T
10	Inner Bearing - 712058		
a	ID	4.2500 - 4.2505	4.2509
	OD	5.750 - 5.751	5.7495

Note. See paragraph 2-12 on repair limits marked \*\*, T, or L.

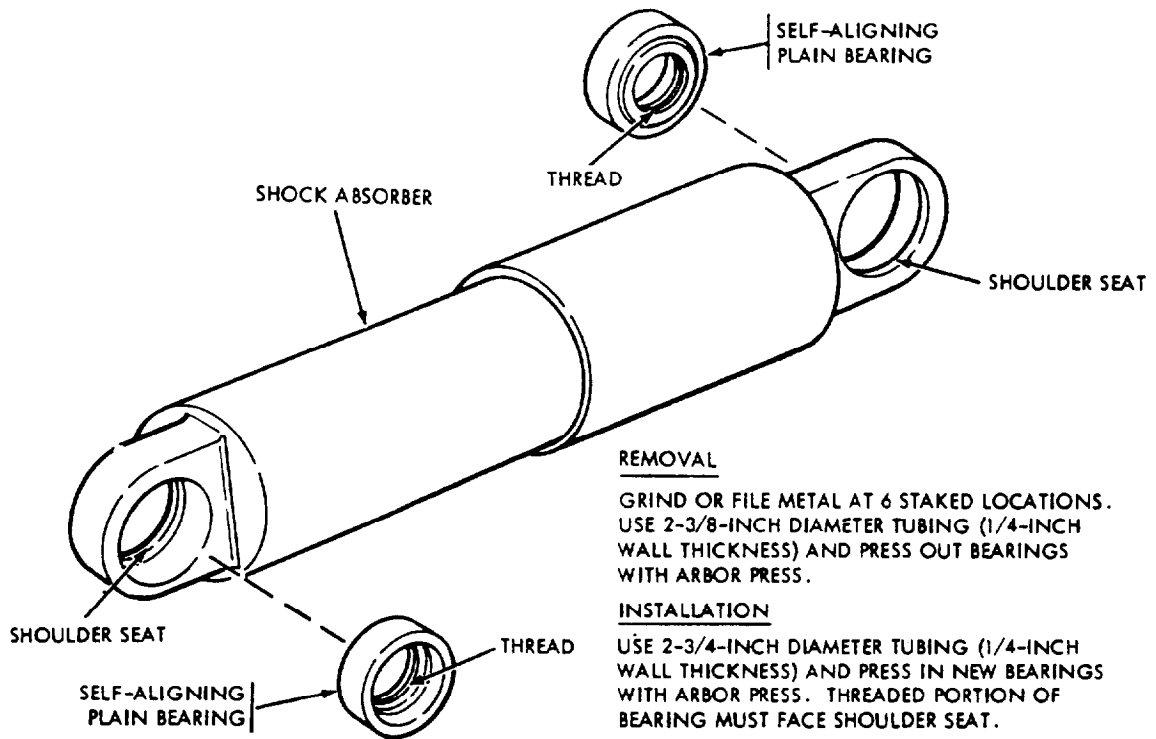

Figure 3-88. Removal/installation of shock absorber bearings.

**Section VII. REPAIR OF HULL COMPONENTS**

**3-37. General**

a. *Scope.* This section illustrates and describes repair of hull components listed in table 3-17.

b. *Detailed References.* Refer to TM 9-2350-230-20-1 for removal, installation, and maintenance of hull components allocated to organizational maintenance.

Table 3-17. Hull Components

Component	Figure reference
Driver's hood and rotatable hatch. . . . .	3-89
Rotation system surfboard . . . . .	3-90, 3-92 through 3-95
Flotation system barrier . . . . .	3-91, 3-96, 3-97

Table 3-17. Hull Components-Continued

Component	Figure reference
Flotation skin. . . . .	3-98, 3-99
Parking brake lock . . . . .	3-100
Mine protective kit - 11652870 . . . . .	3-101,3-102

**3-38. Driver's Hood and Rotatable Hatch**

a. *Removal and Installation* Refer to figure 2-6.

b. *Disassembly, Assembly, and Repair Data* Refer to figure 3-89.

**3-39. Surfboard and Barrier**

a. *Maintenance.* Refer to figure 3-93.

b. *Removal, Installation and Adjustment.* Refer to TM 9-2350-230-20-1.

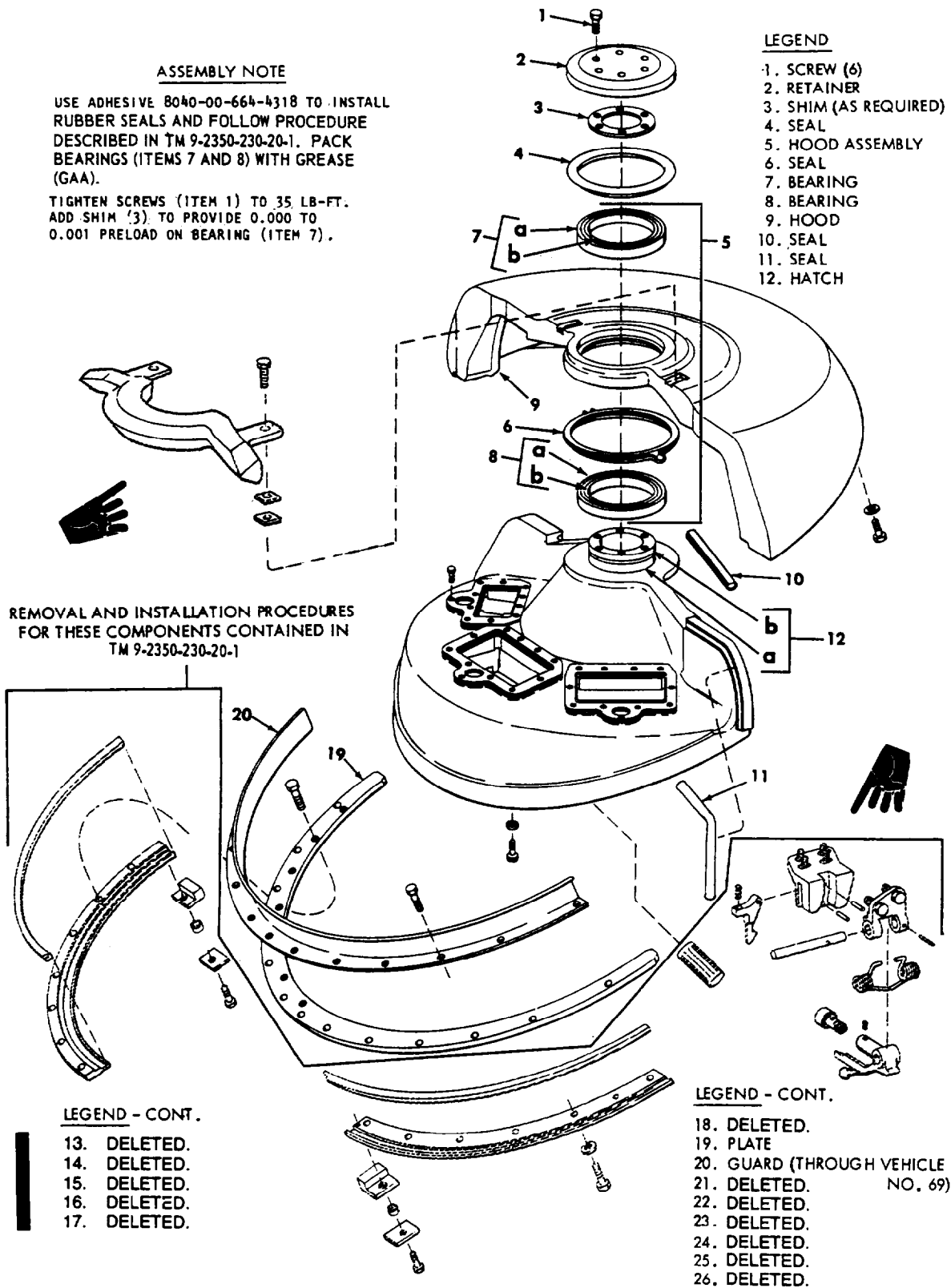

Figure 3-89. Disassembly/assembly-driver's hood and rotatable hatch and repair data.

Table 3-18 Disassembly/Assembly - Driver's Hood and Rotatable Hatch and Repair Data - (see fig 3-89)

Reference no.	Inspection data and points of measurement	Size and fit of new parts	Field repair limit
4	Seal - 5330-00-945-7143 Replace		
6	Seal - 5330-00-945-7140 Replace		
7 & 8	Bearing- 3110-00-912-9515		
a	OD	6.5313 - 6.5323	
b	ID	5.0000 - 5.0010	
7 & 8a-9	Fit of Bearing in Hood	0.0083T - 0.0063%	0.0040T
9	Hood - 10953949 Dia. of bearing bore	6.5235 - 6.5250	
10	Seal - 2590-00-945-7138 Replace		
11	Seal - 5330-00-945-7303 Replace		
12	Hatch - 2510-00-470-4354		
a	OD Journal for Inner Bearing	5.0005 - 5.0015	4.9995
b	OD Journal for Outer Bearing	4.9995 - 5.0005	4.9990
8b-12a	Fit of Bearing on Journal	0.0015T - 0.0005L	0.001L
7b-12b	Fit of Bearing on Journal	0.0005T - 0.0015L	0.0025L
19	Plate - 10954297 (Used through vehicle No. 5) - 11594218 (Used on vehicles No. 6 through 69) - 11605463 (Used starting with vehicle No. 70) - 11652732 and 11652734 (Used starting with vehicle No. 1129)		

Note. See paragraph 2-12 on repair limits marked \*, \*\*, T, or L.

- 1 Screw — 5305-00-959-2698
- 2 Retainer — 2510-00-472-4254
- 3 Window — 9330-00-930-4077
- 4 Screw — 5305-00-269-3240
- 5 Washer — 5310-00-877-5972
- 6 Screw — 5305-00-914-6131
- 7 Hinge — 10955284
- 8 Right Bracket — 2510-00-474-6234
- Left Bracket — 2510-00-474-6904
- 9 Nut — 5310-00-849-7025
- 10 Washer — 5310-00-877-5973
- 11 Nut — 5310-00-868-8062
- 12 Lower Surfboard — 2510-00-453-5359
- 13 Eyebolt — 5306-00-271-4776
- 14 Upper Surfboard — 2540-00-133-9815

- 14.1 Screw — 5305-00-959-2703
- 14.2 Plate — 5340-00-472-4252
- 15 Bracket — 5340-00-472-4324
- 16 Deleted.
- 17 Seal — 5330-00-476-9309
- 18 Deleted.
- 19 Deleted.
- 20 Deleted.
- 21 Gasket — 5330-00-944-3813
- 22 Retainer — 2510-00-472-4274
- 23 Deleted.
- 24 Deleted.

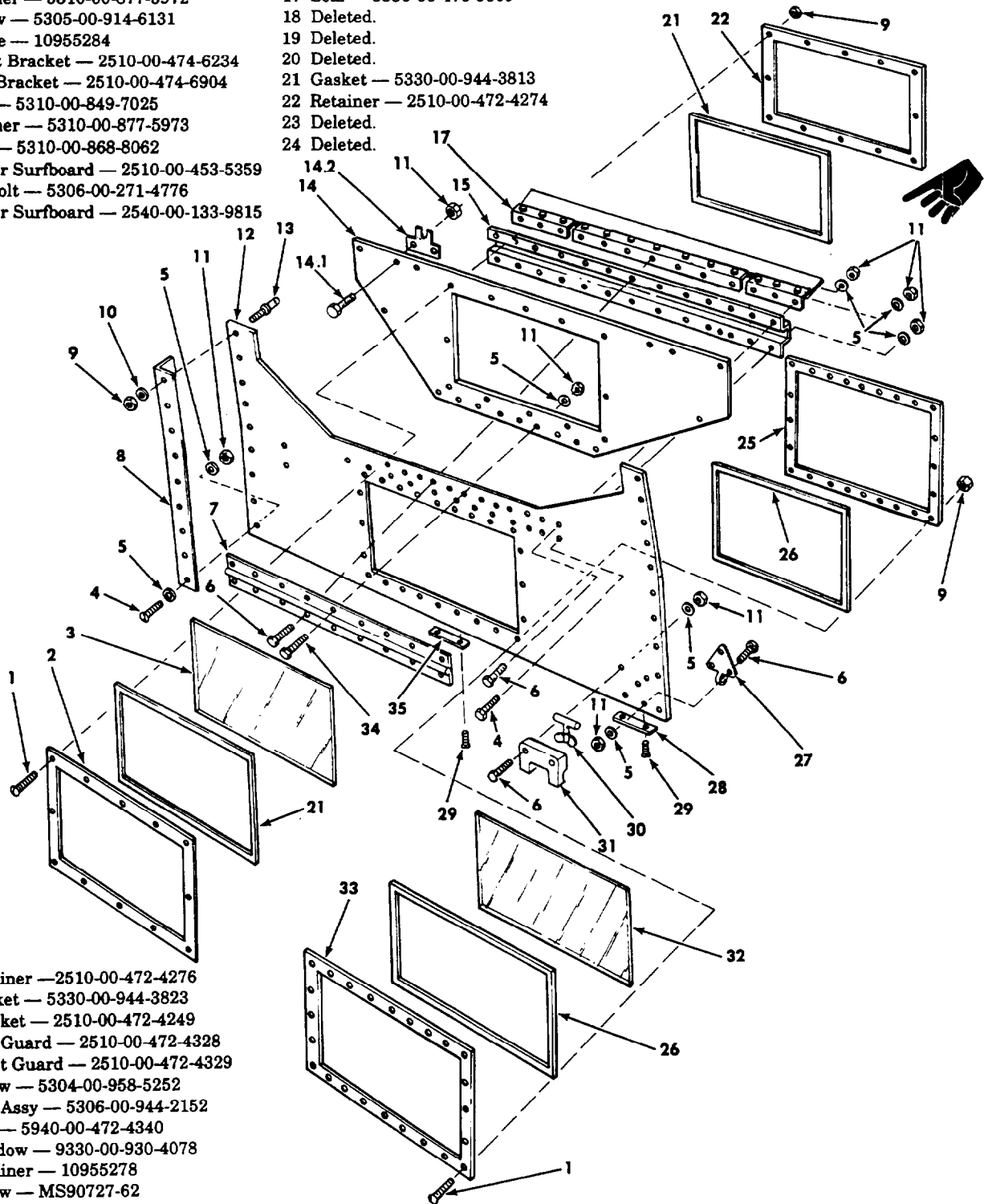

- 25 Retainer — 2510-00-472-4276
- 26 Gasket — 5330-00-944-3823
- 27 Bracket — 2510-00-472-4249
- 28 Left Guard — 2510-00-472-4328
- Right Guard — 2510-00-472-4329
- 29 Screw — 5304-00-958-5252
- 30 Bolt Assy — 5306-00-944-2152
- 31 Lug — 5940-00-472-4340
- 32 Window — 9330-00-930-4078
- 33 Retainer — 10955278
- 34 Screw — MS90727-62
- 35 Guard — 10956067

Figure 3-93. Surfboard disassembly/assembly.

Table 3-19. Repair of Flotation Barrier

Step	Procedure
	<b>NOTE</b>
	<i>If ambient temperature is above 25°F., ripped or punctured barriers may be repaired with polychloroprene coated nylon cloth and neoprene rubber adhesive contained in repair Kit -5702943.</i>
1	Cut patch at least 3 inches longer than tear or larger than hole in all directions.
2	Buff damaged area and one side of patch material to expose fresh rubber using wire brush, buffer, emery cloth or other suitable material. Buff area 1 inch larger in diameter than patch.
3	Remove buffing residue and clean buffed areas with trichlorethylene solvent.
4	Allow solvent to dry.
5	Brush on thin coat of cement to both the repair area and patch. (Make sure cemented area of item to be repaired is larger than pat.&.)
6	Let cement dry 15 to 30 minutes depending on the ambient temperature with the cooler temperatures requiring the most time.
	<b>CAUTION</b>
	<i>Do not dip application brush into loxite can. Rubber dust picked up by the brush in application will contaminate cement in the can for future use. If all contents of can are not required for a repair, pour estimated amount of cement required into another container, securely seal can, and work out of open container. Discard any exposed cement after repair has been completed</i>
7	Apply a second coat of cement to both articles allowing approximately the same drying time.
8	Apply a third coat of cement to both articles and let dry from 3 to 5 minutes or until tacky.
9	Carefully place patching material over area to be patched and with roller, or other suitable item, (such as cement can); roll from center of patch to outside edges in order that all entrapped air bubbles and wrinkles may be rolled out.
	<b>NOTE</b>
	<i>Use board or flat object larger than patch area to back up patch during application</i>
10	Allow repair to cure without flexing for at least 24 hours.

**3-40. Repair of Flotation Skin**

*a. Description*

(1) Thin aluminum plates ( $\frac{1}{16}$  to  $\frac{3}{16}$ -inch thick (figs. 3-98 and 3-99)) welded to framework mounted on the hull form a reservoir on each side of vehicle for plastic foam, a material used to maintain buoyancy of vehicle while it is operating in deep water.

(2) Side plates (fig. 3-99) are secured to framework by special button-type MIG spot welds.

*b. Removal of Damaged Plates.* Use metal-cutting type circular power saw, hammer, chisel, or similar tools to cut damaged area from vehicle so that replacement plate is always mounted between framework uprights as indicated below:

(1) If damaged area is located between framework uprights A and B, (fig. 3-99), cut and remove entire portion of side plate between A and B (AB).

(2) If damaged area is located between framework uprights B and D (fig. 3-99), remove entire portion of side plate between uprights B and D (BD).

*c. Repair of Damaged Framework*

(1) Remove plastic foam as necessary to obtain access to damaged area.

(2) Straighten or remove damaged portions of framework, if necessary, fabricate components from available sheet or angle aluminum.

(3) Weld replacement components in position (para 2-10).

*d. Replacement of Plastic Foam* Use MIL-P-43110 (MR) Type I or Type II, Class 1 Density (2.0 ± 0.2 lbs. cu. ft.) thermal plastic foam. Type I consists of molded planks and boards and Type II consists of two liquids which when mixed cause formation of foam in place.

(1) *Use of type I (molded planks and boards).*

Remove damaged foam and trim replacement foam to closely fit cavity. Use care not to crush foam during fitting and installation.

(2) *Use of type II (liquid) (resin and hardener).*

(a) Place vehicle so opening for filling void with foam is as close to horizontal as possible; if this is impossible to do, devise a dam to retain foam in specified area and build up until entire void is filled.

(b) Mix resin and hardener liquids in proportions as directed on package in ambient temperature of 60° to 95°F. Stir until solution begins to cream and then immediately pour into repair area. Solution will completely solidify approximately 30 seconds after creaming starts (2.2 pounds of mixture will fill one cubic foot when solidified).

**WARNING**

If mixture splashes into eyes, immediately flush with water to stop chemical action.

(c) Use saw or similar tool to trim excess foam from vehicle.

*e. Replacement of Damaged Skin*

(1) Attaching replacement skin to the framework can be accomplished by using one of the following procedures:

(a) *MIG spot weld (button-type).* If equipment is available, this procedure will match production installation. All surfaces must be thoroughly cleaned of dust, grease, paint, and preservatives by use of chemicals and/or stainless steel wire brush. Apply adhesive 8040-00-582-4596 to back side of plate and mount in position before welding. Welding plates by this method is best performed if work surface is on or near a horizontal plane. Vertical application of this method is extremely difficult and not recommended.

(b) *Drill and rivet.* After replacement plate has been cut to fit damaged area, drill holes for blind rivets, apply adhesive (see above) to plate, mount plate and secure with blind rivets as follows:

Rivet Number	Plate Thicknesses
MS24662-79	0.256 to .296
MS24662-81	0.296 to .328
MS24662-85	0.359 to .390

(c) *Plug or slot weld.* After plate has been cut to fit, drill holes or slots around edge of plate, clean affected areas with chemicals and/or stainless steel

wire brush, apply adhesive (see above) and weld through holes to flotation frame.

(2) *Split Corners or Defective Edges.* Remove any torn or distorted pieces of metal and tack weld angle aluminum or formed sheet aluminum to existing plates.

f. *Painting.*

(1) Grind off excess weld spatters.

(2) Apply prime paint per Spec., TT-P-666 and O.D. exterior enamel per Spec., TT-E-529.

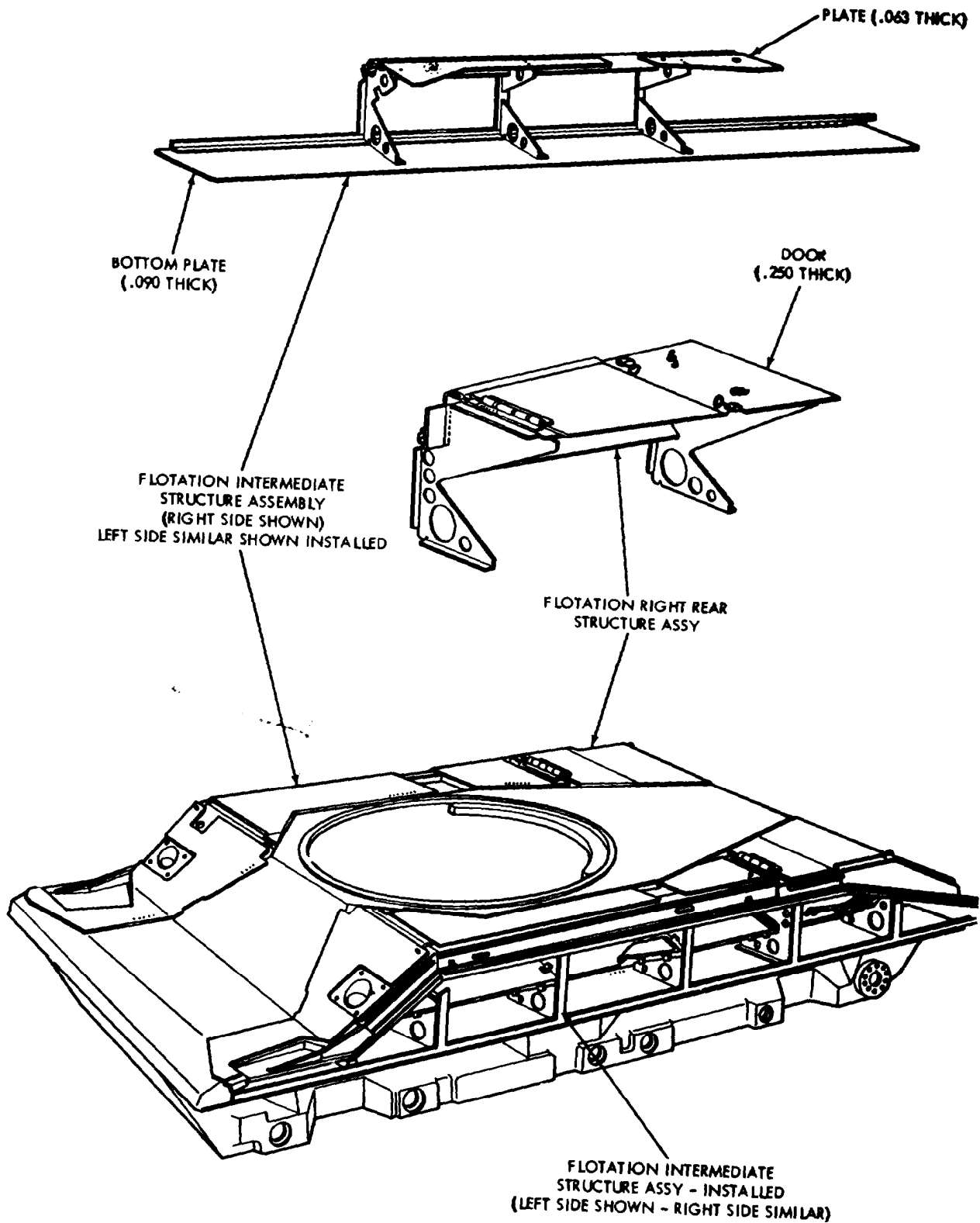

ORD E70510

Figure 3-98. Repair of flotation skin (1 of 2).



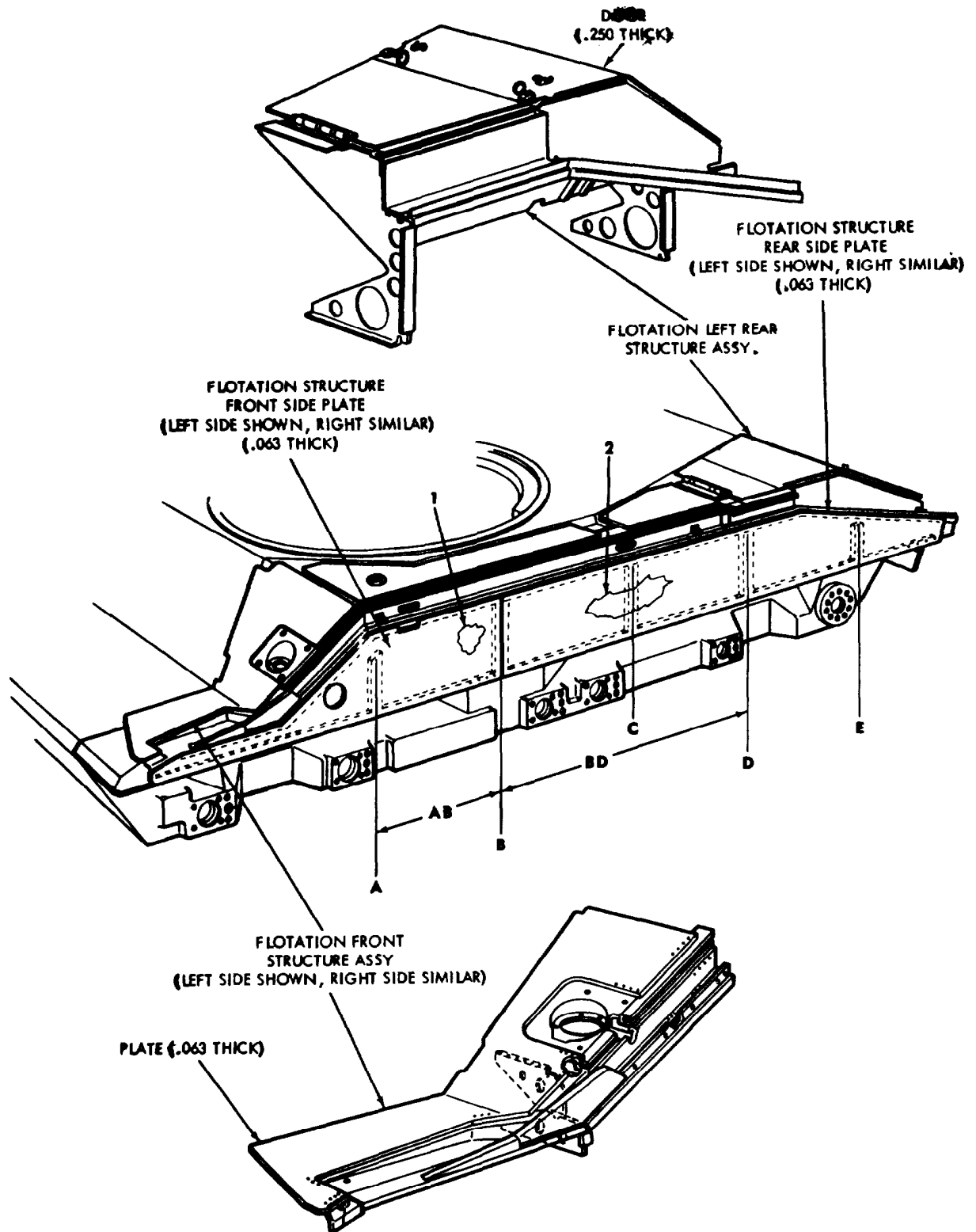

ORD E70511

Figure 3-99. Repair of flotation skin (2 of 2).

**3-41. Parking Brake Lock**

a. Removal and Installation. Refer to TM 9-2350-230-20-1.

b. Disassembly and Assembly. Refer to figure 3-100.

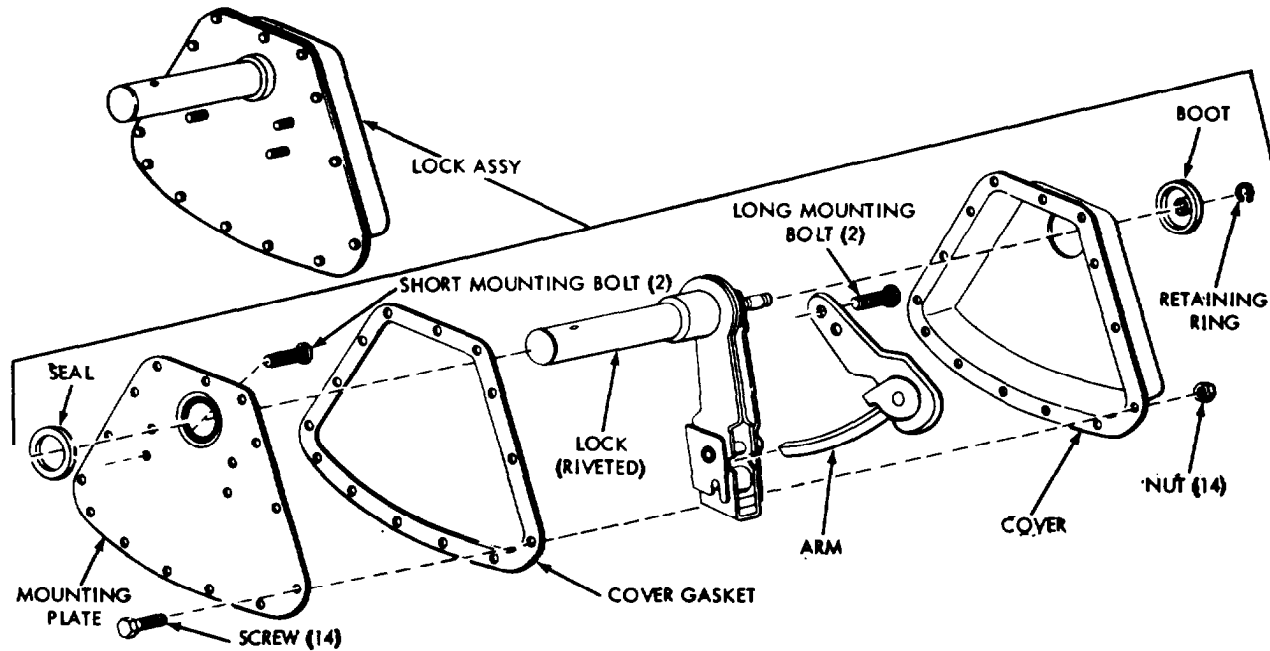

ORD E70521

Figure 3-100. Disassembly/assembly of parking brake lock.

**3-42. Mine Protective Kit - 11652870**

a. Removal and Installation of Hull Bottom Protective Plate. Refer to figure 3-101.

b. Removal and Installation of Hull Side Protective Plates. Refer to figure 3-102.

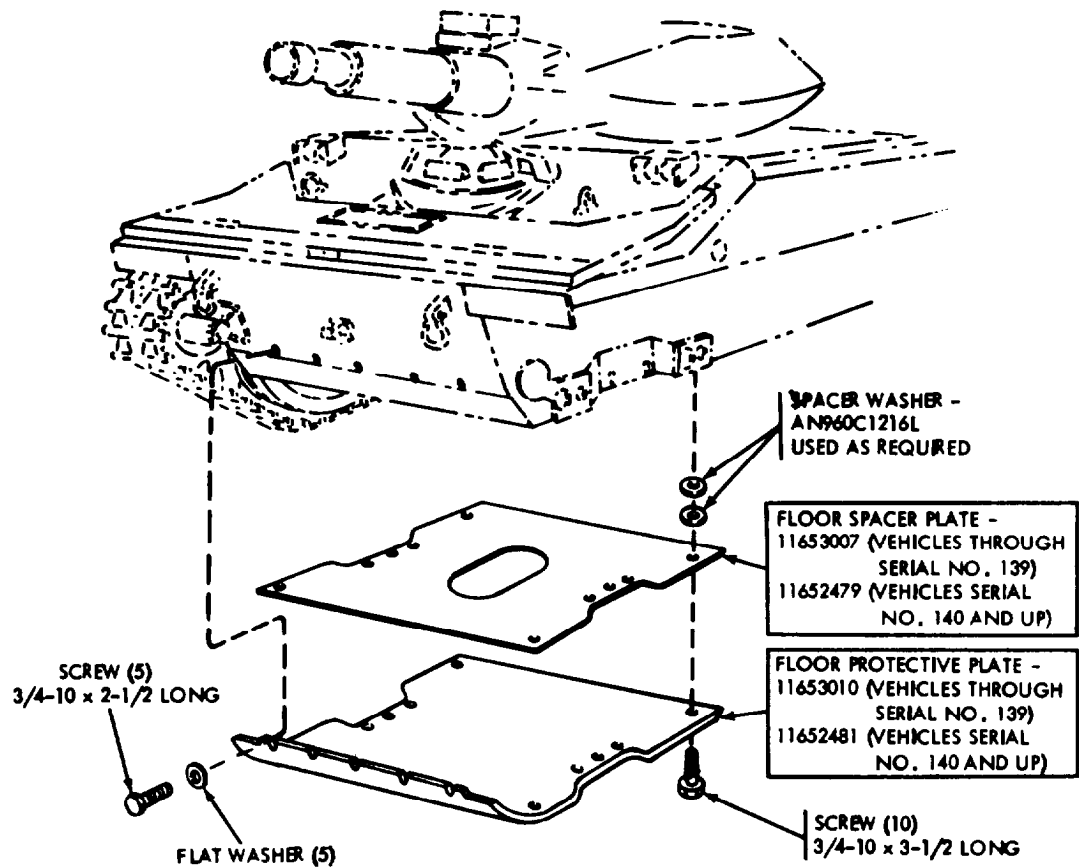

INSTALLATION

1. REMOVE 15 SCREWS MS90728-183 AND 15 WASHERS 10910174-8 WHICH PLUG HOLES IN VEHICLE HULL. STORE FOR REUSE WHEN MINE KIT FLOOR PLATES ARE REMOVED.
2. PLACE FLOOR PROTECTIVE PLATE AND FLOOR SPACER PLATE ON 3 JACKS (2 IN FRONT, 1 IN REAR) WITH TOP OF SPACER PLATE APPROXIMATELY 10-INCHES ABOVE GROUND.

WARNING: PROTECTIVE PLATE WEIGHS 1,250 POUNDS AND SPACER PLATE WEIGHS 174 POUNDS. USE ADEQUATE LIFTING DEVICES AND USE CAUTION WHILE POSITIONING PLATES AND VEHICLE.

3. DRIVE VEHICLE OVER PLATES, ALIGNING CUTOUTS IN PLATES WITH VEHICLE SHOCK ABSORBERS.
4. USE JACKS AND RAISE PLATES UNTIL PLATES CONTACT HULL. CHECK AND REALIGN HOLES AS NECESSARY.
5. INSTALL 10 SCREWS (3-1/2-INCHES LONG) ON BOTTOM AND 5 SCREWS (2-1/2-INCHES LONG) ON FRONT OF HULL.
6. MEASURE GAPS (IF ANY) BETWEEN SPACER PLATE AND VEHICLE HULL AT 10 SCREW LOCATIONS. LOOSEN ALL SCREWS. REMOVE ONE SCREW AT A TIME AND SLIDE REQUIRED SPACER WASHERS (1/32-INCH THICK) INTO GAP.
7. TIGHTEN ALL SCREWS TO 250-310 LB -FT.

NOTE. DRIVER'S ESCAPE HATCH COVER CANNOT BE REMOVED WHEN MINE KIT FLOOR PLATES ARE INSTALLED.

REMOVAL

REVERSE INSTALLATION STEPS. INSTALL 15 PLUG SCREWS AND WASHERS.

**TA 014829**

Figure 3-101. Remove/installation of mine protective kit - 11652870 hull bottom protective plate.

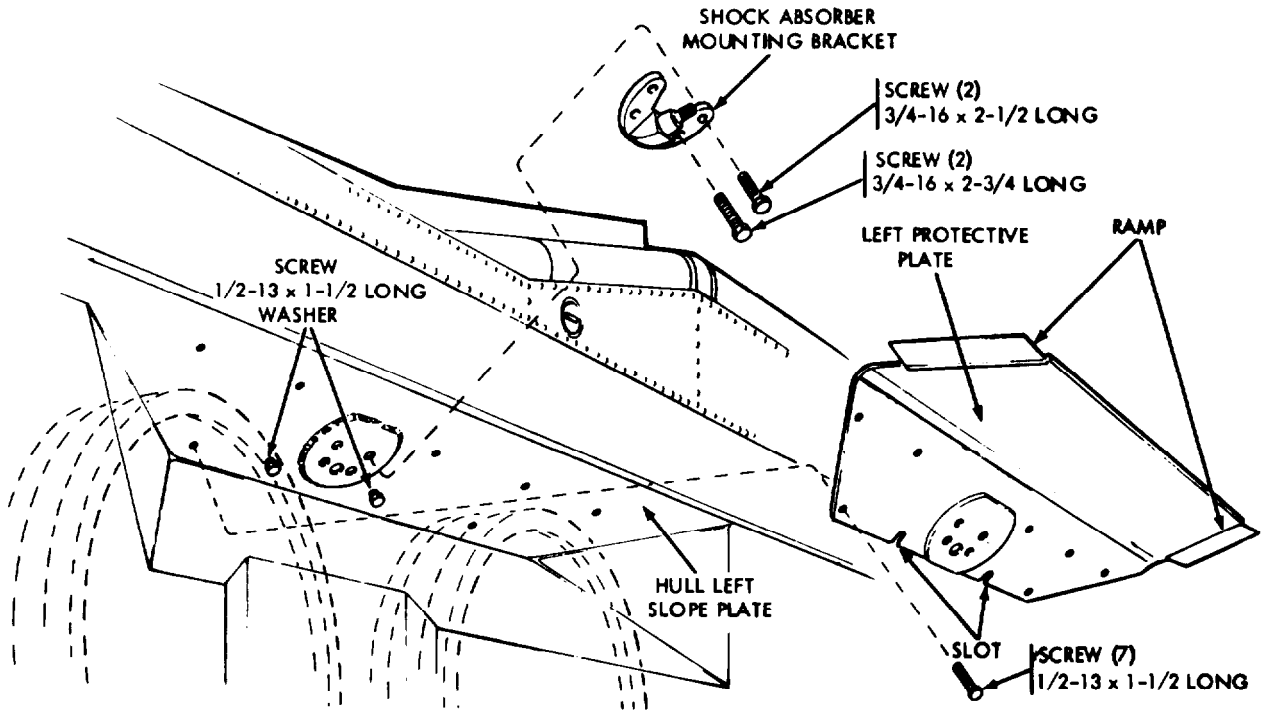

INSTALLATION

1. DISCONNECT TRACKS WEAR IDLER WHEELS (TM 9-2350-230-20-1) AND ROLL VEHICLE BACKWARD UNTIL TOPS OF FIRST THREE ROAD WHEELS ARE FREE OF TRACK.
  2. REMOVE LEFT AND RIGHT FRONT SHOCK ABSORBERS FROM MOUNTING BRACKETS AND THEN REMOVE MOUNTING BRACKETS FROM HULL (TM 9-2350-230-20-1)
  3. REMOVE 19 SCREWS - MS90728-107 AND WASHERS - 10941915-5 FROM HULL LEFT AND RIGHT SLOPE PLATES (9 LEFT SIDE AND 10 RIGHT SIDE). STORE SCREWS AND 15 WASHERS FOR REUSE WHEN MINE KIT SIDE PROTECTIVE PLATES ARE REMOVED.
  4. PARTIALLY INSTALL 4 SCREWS - MS90728-113 (2 LEFT, 2 RIGHT) ADJACENT TO AND BELOW SHOCK ABSORBER BRACKET MOUNTING AREA. SCREWS SHOULD PROTRUDE APPROXIMATELY 1-INCH.
  5. INSTALL LEFT AND RIGHT PROTECTIVE PLATES WITH PLATE SLOTS LOCATED OVER PROTRUDING SCREWS. USE 2 JACKS TO SUPPORT EACH PLATE AND TURN 4 SCREWS (STEP 4) TO POSITION SCREW HEADS APPROXIMATELY 1/16-INCH FROM PLATES. INTEGRAL RAMPS ON PROTECTIVE PLATES MUST CONTACT SPONSON BOTTOM PLATE.
- WARNING: EACH PLATE WEIGHS APPROXIMATELY 250 POUNDS. USE CAUTION WHEN HANDLING PLATES.
- CAUTION: SPONSON BOTTOM PLATE MAY BE DAMAGED IF PROTECTIVE PLATES ARE FORCED INTO POSITION. BEND RAMPS AS NECESSARY TO CONTACT SPONSON BOTTOM PLATE WITHOUT UNDUE PRESSURE.
6. INSTALL SHOCK ABSORBER MOUNTING BRACKETS USING 4 SCREWS - MS90727-189 (2-1/2 LONG) AND 4 SCREWS - MS90727-190 (2-3/4 LONG). USE SEALANT TYPE II MIL-S-45180 ON SCREWS AND BRACKET TAPERED SHANK. DO NOT TIGHTEN SCREWS.
  7. APPLY SEALANT TYPE II MIL-S-45180 TO THREADS AND LOOSELY INSTALL 15 SCREWS - MS90728-113 7 LEFT, 8 RIGHT).
  8. PRY UPWARD AGAINST PROTECTIVE PLATES AND TIGHTEN 15 SCREWS TO 80-90 LB-FT.
  9. REMOVE 4 SCREWS AT PLATE SLOTS (STEPS 4 AND 5), APPLY SEALANT AND REINSTALL SCREWS USING 4 WASHERS - 10941915-5 REMOVED IN STEP 3. TIGHTEN SCREWS TO 80-90 LB-FT.
  10. TIGHTEN SHOCK ABSORBER SCREWS (STEP 6) TO 290-350 LB-FT.
  11. INSTALL SHOCK ABSORBERS AND CONNECT AND ADJUST TRACK (TM 9-2350-230-20-1)

REMOVAL

REVERSE INSTALLATION STEPS. INSTALL 19 PLUG SCREWS AND WASHERS.

**TA 014801**

Figure 3-102. Removal/installation of mine protective kit - 11652870 hull left and right side protective plates (left shown).

c. Hull Floor Preparation Instructions for Installation of Mine Protective Kit

- (1) Grind welds under floor, where armor will contact,, to a flush condition. The weld on front edge of floor need not be ground- Prime and paint as required.
- (2) Place floor armor plate level on four jacks; place aluminum spacer plate on top of armor and align bolt holes. Adjust to approximately 10 inches above ground.
- (3) Drive vehicle over plates, aligning shock absorber cutouts in plates with vehicle shock absorbers (fig. 3-103).
- (4) Raise plates until they contact hull floor. Center side to side and make sure the front edge of plate is tight against the vehicle front slope plate. Install safety blocking under plates.
- (5) Center punch hull floor and front slope plate at 15 hole locations. Use transfer punches if available (fig. 3-103).
- (6) Lower plates. Back vehicle clear.
- (7) Drill 1/4-inch pilot holes at 15 locations. Do not

allow drill tip to penetrate deeper than 1 1/4 inches at five locations across the front of the hull and 2 1/4 inches at 10 locations under hull floor.

(8) Drill the 15 holes with a 21/32-inch diameter drill being careful not to allow deeper penetration than in paragraph (7), above.

(9) Tap five locations on front of slope plate 1 1/4 inches deep, and 10 locations on hull floor 21/8 inches deep using a 3/4-10 UNC-2B tap.

(10) Drive vehicle over plates and raise plates into position.

(11) Install and tighten 10 screws MS90728-193 on under-side and five screws MS90728-189, with washers 10941915-8, across front (fig. 3-103).

(12) Measure and record gaps, if any, between plates and hull floor. Loosen all bolts. Remove one bolt at a time and slide approximate number of washers. AN 960-C1216L (1/32-inch thick) into gap and replace screw (fig. 3-103).

(13) Tighten all screws to 250-310 lb-ft torque.

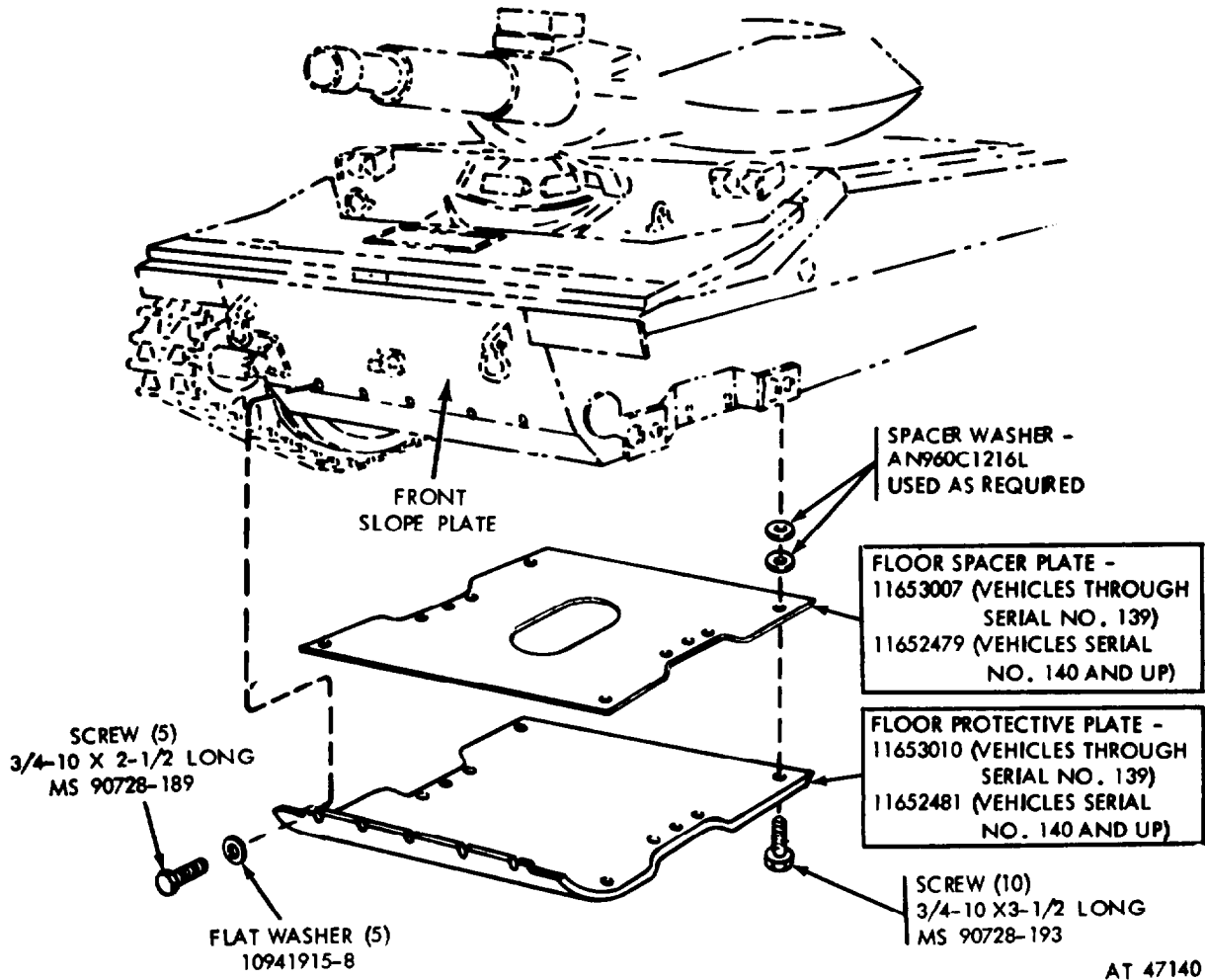

Figure 3-103. Preparing hull floor for armor plate

d. Hull Sides Reparation Instructions for Installation of Mine Armor Kit

(1) Disconnect tracks near idler wheels (TM 9-2350-230-20-1). Roll vehicle backward until tops of front three roadwheels are clear of tracks.

(2) Remove shock absorbers from upper bracket only.

(3) Remove eight screws, and two shock-absorber upper brackets (right and left). Retain brackets.

(4) Prepare hull at armor plate contact area by grinding excess welds flush to permit armor plate installation. Prime and paint affected areas (fig. 3-104).

**NOTE**

Some vehicles below Serial No. 550 may have flotation chambers welded to hull immediately fore and aft of shock-absorber upper bracket mounting surface (fig. 3-105). If so equipped, remove plates from hull with chisel and hammer or power chipping hammer. Remove flotation foam and grind affected areas smooth. Prime paint as required.

(5) Raise armor plate (11652808 left, 11652897, right) into position over existing shock-absorber mounting bracket holes. Use mechanical handling equipment if available. Each plate weighs approximately 250 pounds (fig. 3-104).

(6) Install retained shock-absorber bracket with two new upper screws MS90727-189 and two new

lower screws MS90727-190. Apply a small amount of sealant (Type II MIL-S45180) on screw threads and bracket pilot boss. Do not fully tighten screws at this time (fig. 3-104).

(7) With armor plate against hull, pry plate upward as much as possible and tighten four screws to 290-350 lb-ft torque.

**NOTE**

Bend sheet metal ramps at front and rear armor plate as necessary to provide intimate, but not damaging, contact with the underside of flotation structure (sponson). This must be accomplished as screws are tightened (fig. 3-104).

(8) Transfer punch remaining hole locations through armor plate.

(9) Drill (through) 1/4-inch diameter holes at all locations.

(10) Final drill 27/64-inch diameter (through) at all holes. Tap (through) 1/2-13 UNC-CB, at all locations.

(11) Install screws MS90728-113 (10 right, 9 left), applying small amount of sealant (type II, MIL-S-45180) to threads. Tighten to 80-90 lb-ft torque (fig. 3-104).

(12) Install shock absorbers. Tighten castellated nuts to 120 lb-ft torque. Lock with new cotter pin.

(13) Connect and adjust tracks.

(14) Prime and paint any bare metal.

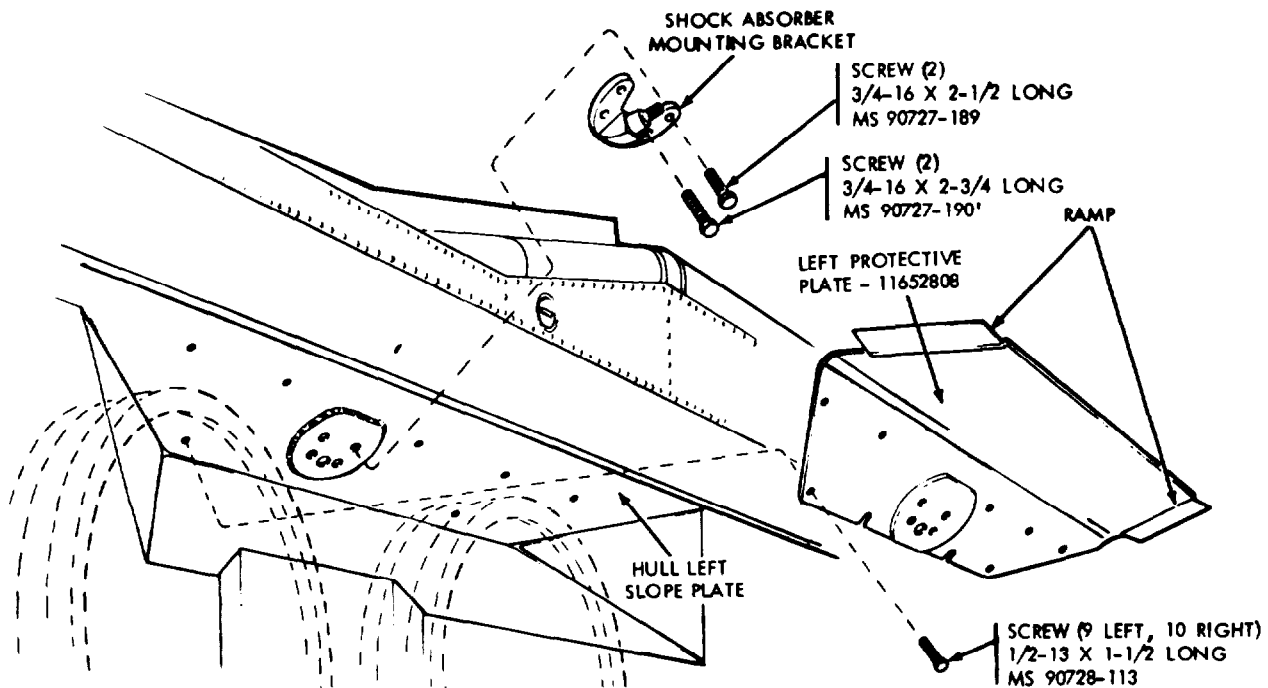

AT 47141

Figure 3-104. Preparing hull sides for armor plate.

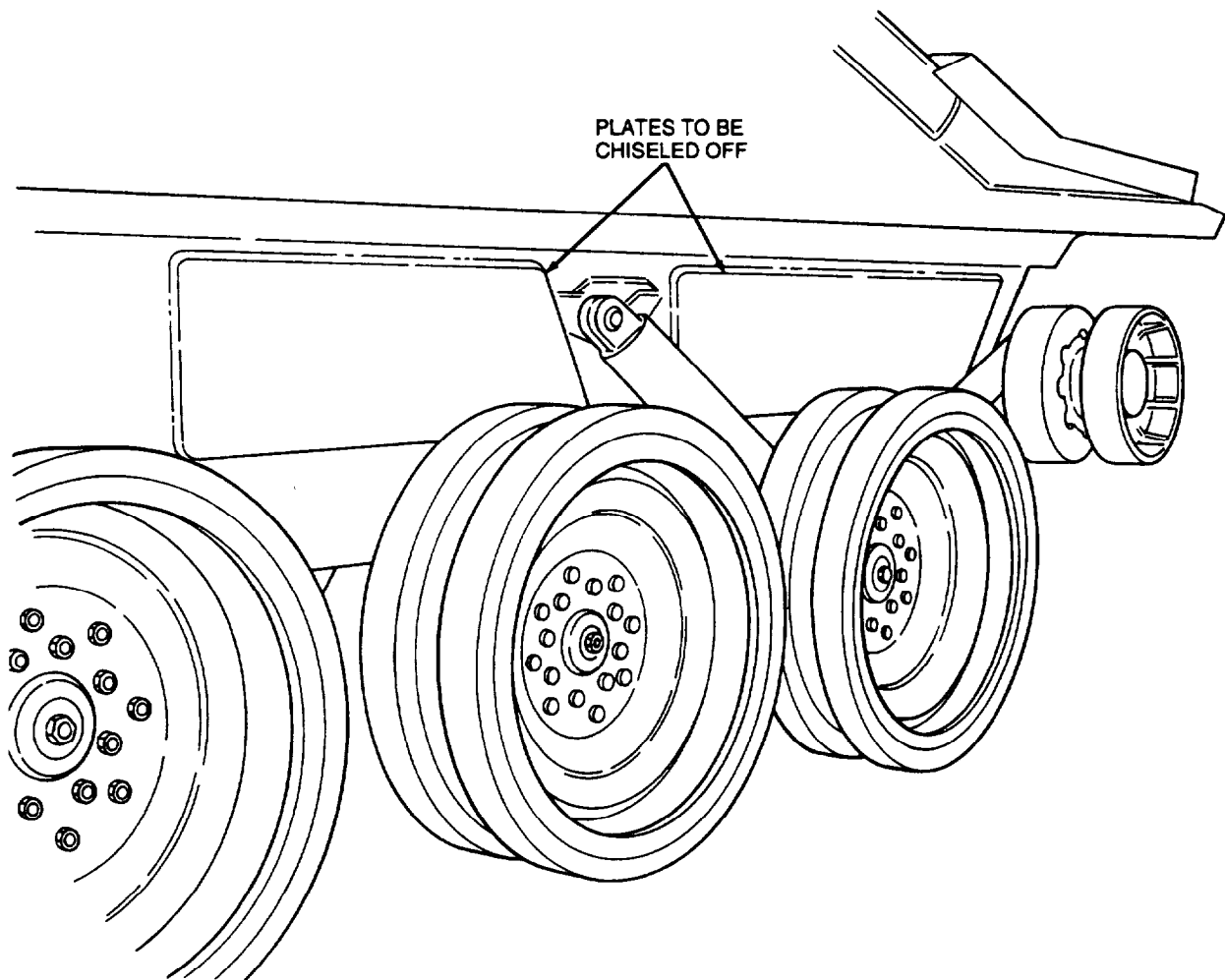

Figure 3-105. Flotation chambers.

## Section VIII. REPAIR OF HULL ACCESSORIES

### 3-43. General

*a. Scope.* This section illustrates and describes repair procedures for the hull accessories.

*b. Detailed References.* For removal and installation of hull accessories, refer to TM 9-2350-230-20-1. Refer to figure 3-63 for personnel heater wiring harness.

### 3-44. Hull Accessories (Bilge Pump, Personnel Heaters, Fire Extinguishers (Recharging))

*a. Bilge Pump.* Refer to figures 3-106 through 3-108

for disassembly, assembly, and repair data.

*b. Personnel Heater (11618978).* Refer to figures 3-109 through 3-118 for disassembly and assembly. Refer to figure 3-119 through 3-121 for repair data.

*c. Personnel Heater MIL-H-46792-2-1.* Refer to figures 3-126 through 3-132 for disassembly and assembly. Refer to table 3-24 for repair data.

*d. Fire Extinguishers (Recharging).*  
See *i* below.

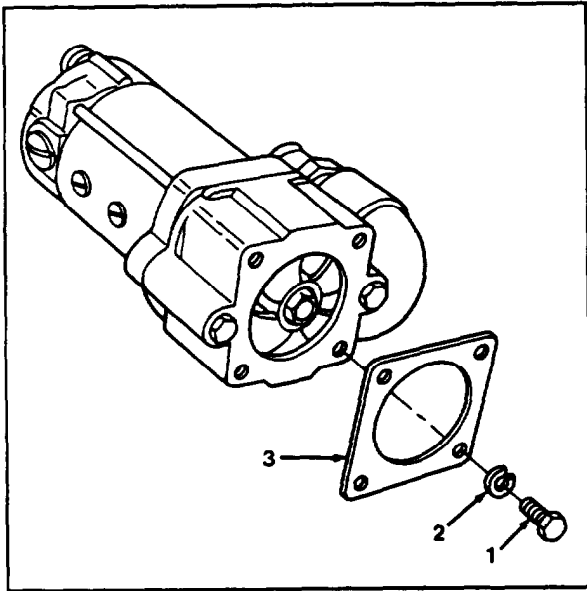

**DISASSEMBLY**

REMOVE COMPONENTS IN NUMERICAL SEQUENCE TO DISASSEMBLE BILGE PUMP.

- 1. MOUNTING SCREW (4)
- 2. LOCK WASHER (4)
- 3. MOUNTING GASKET

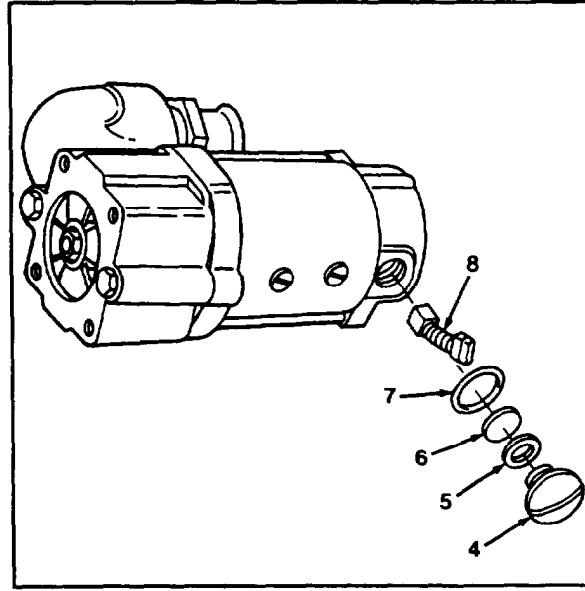

- 4. BRUSH CAP (2)
- 5. BOWED WASHER (2)
- 6. BRUSH CAP INSULATOR (2)
- 7. PREFORMED PACKING (2)
- 8. ROTOR BRUSH (2)

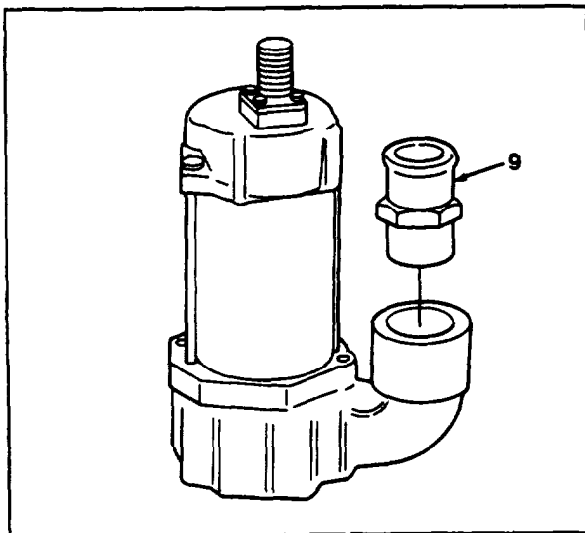

- 9. OUTLET TUBE ADAPTER

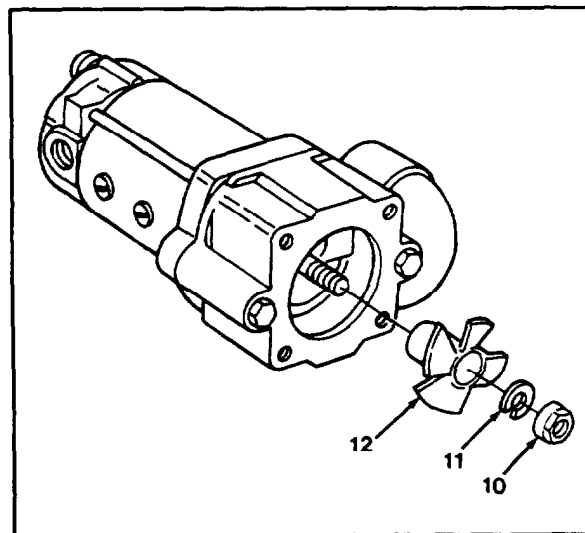

- 10. IMPELLER NUT (HOLD IMPELLER WITH WOOD BLOCK TO REMOVE/INSTALL NUT)
- 11. IMPELLER LOCK WASHER
- 12. IMPELLER (PRY OFF IF NECESSARY/TAP ON WITH MALLET)

ORD E 70443

Figure 3-106. Disassembly/assembly - bilge pump and repair data (1 of 3).





Figure 3-107. Disassembly/assembly - bilge pump and repair data (2 of 3).

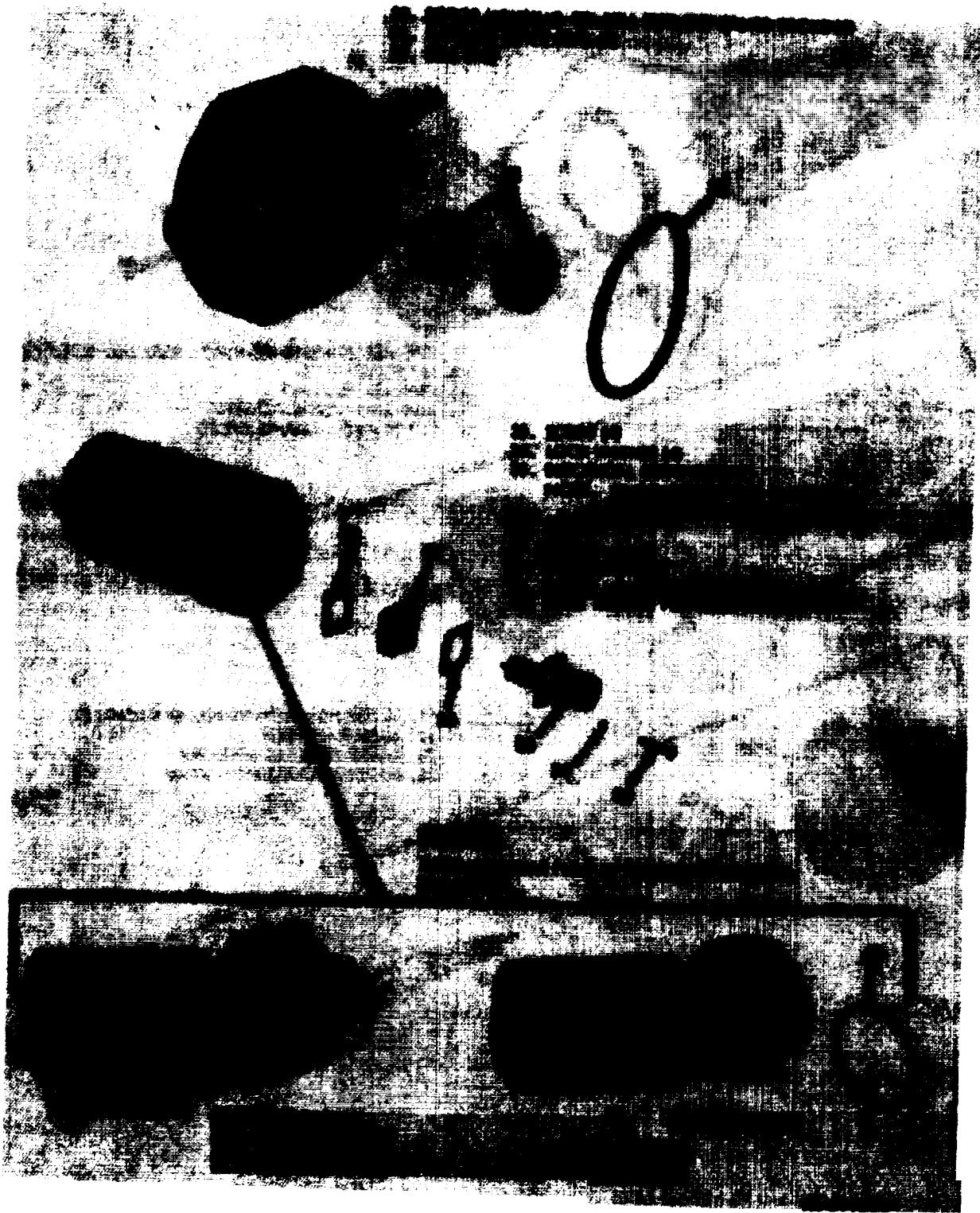

Figure 3-108. Disassembly/assembly - bilge pump and repair data (3 of 3).

Tab& 3-20. Bilge Pump Repair Data (see figs. 3-106 through 3-108)

Reference no.	Inspection data and points of measurement	Size and fit of new parts	Field repair limit
3	Gasket-10865526		
5	Replace Bowed Washer - 10866219		
6	Replace Brush Cap Insulator - 108865844		
8	Replace Rotor Bush - 10863496		
16	Replace if cracked, chipped or worn more than 1/2 of length. Gasket-10865525		
26	Replace Bearing - 700061(700028 - Effective with vehicle Serial No. 740)		
	OD	1.3775 to 1.3780	
	ID	0.5903 to 0.5906	
	Fit of bearing to rotor journal	0.0005T to 0.0001L	•
28	Bearing- 700021 (700157 - Effective with vehicle Serial No. 740)		
	OD	0.8657 to 0.8661	
	ID	0.3147 to 0.3150	
	Fit of bearing to rotor journal	0.0004T to 0.0002L	•
39	Rotor Assembly- 10863495		
	Test; turn down commutator		
	Bearing Journal (large bearing)	0.5905 to 0.5908	
	Bearing Journal (small bearing)	0.3148 to 0.3151	
30 & 40	Preformed Packing - 96906-29513-228		
31	Replace Impeller Shaft Seal - 10865529		
36 & 38	Replace Gasket-7358501		
	Replace		

Note. See paragraph 2-12 on repair limits marked \*, \*\*, T, or L

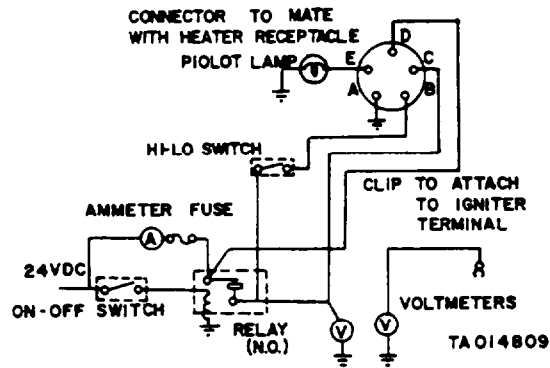

Figure 3-131. Interconnection test set-up.

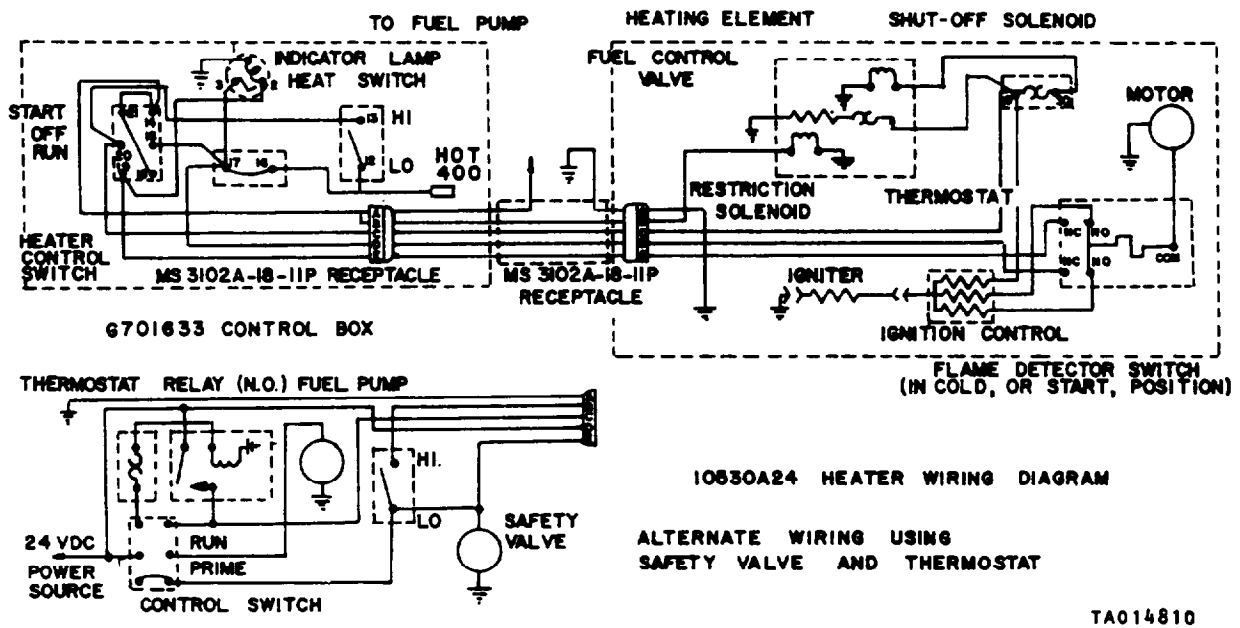

Figure 3-132. DC power and ignition control system.

*i. Recharging Engine Compartment and Crew Compartment Fire Extinguisher Cylinders.*

Return to Depot Maintenance for recharging engine compartment and crew compartment fire extinguishers.

*j. Deleted.*

*k. Disassembly/Assembly of Crew Compartment  
Fire Extinguisher and Valve Assembly 4210-  
00-502-5501. Refer to figure 3-138.*

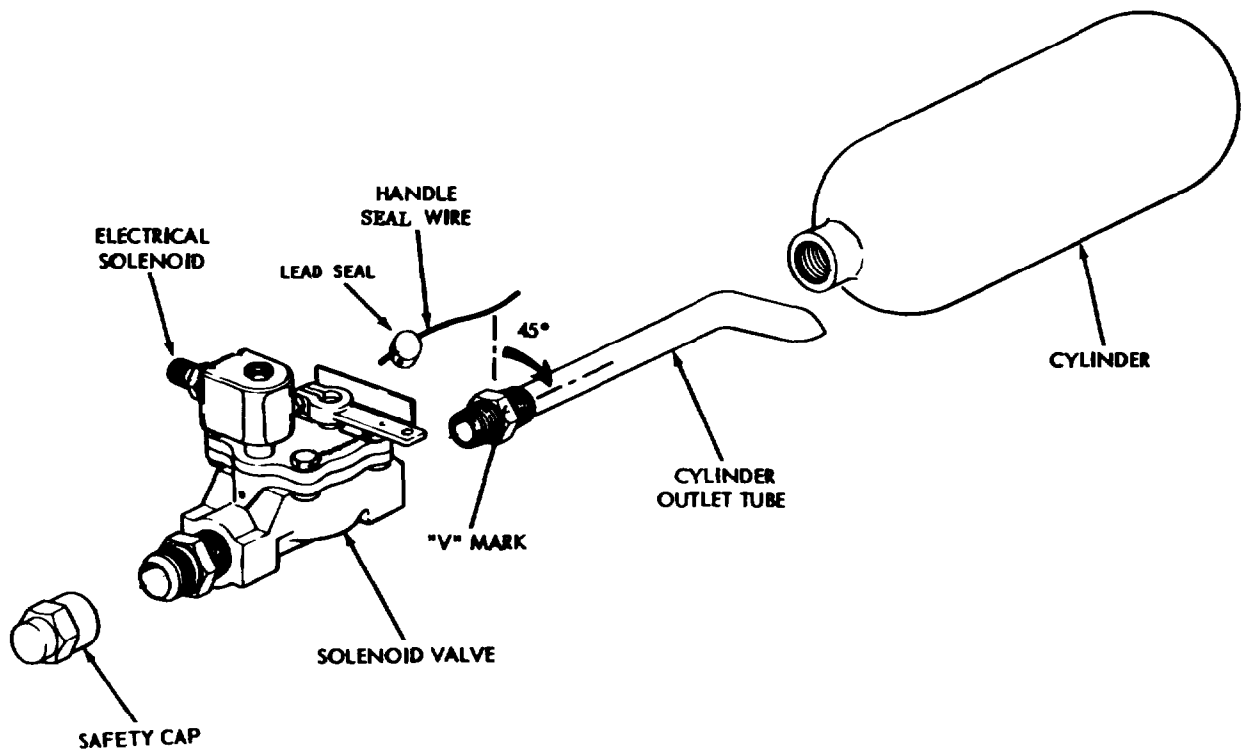

#### ASSEMBLY NOTES

1. CLEAN, FLUSH, AND DRY CYLINDER BEFORE ASSEMBLY.
2. USE PIPE THREAD SEALANT ON CYLINDER, OUTLET TUBE, AND SOLENOID VALVE THREADS.
3. ASSEMBLE TUBE AND VALVE WITH "V" MARK IN POSITION 45° FROM CENTERLINE. THIS ARRANGEMENT WILL POINT THE END OF THE TUBE DOWNWARD IN THE HORIZONALLY INSTALLED FIRE EXTINGUISHER ASSEMBLY, AND PERMIT DISCHARGE OF ALL THE AGENT.

NOTE: THE CORRECT POSITION MUST BE MADE WHEN ASSEMBLING THE FIRE EXTINGUISHER ASSEMBLY PRIOR TO CHARGING IT WITH THE AGENT; IT CANNOT BE SUCCESSFULLY ADJUSTED AFTER; OR LEAKAGE MAY RESULT.

4. DO NOT INSTALL HANDLE SEAL WIRE OR SAFETY CAP UNTIL CYLINDER AND VALVE ASSEMBLY IS CHARGED. TAG ASSEMBLY DISCHARGED AND REMOVE TAG AFTER CHARGING.

CATION: DO NOT LIFT CYLINDER AND VALVE-BY ELECTRICAL SOLENOID OR ACTUATING SHAFT WILL BE DISTORTED AND VALVE WILL NOT OPERATE.

**TA 014812**

Figure 3-138. Disassembly/assembly of crew compartment fire extinguisher system cylinder and valve - 11665102.

**Section IX. WINTERIZATION KIT**

**3-45. General**

*a. Scope.*

(1) Installation of early winterization kit 10955778 (fig. 3-139) is illustrated and described in paragraph 3-46.

(2) Installation of later winterization kit 11678893 (includes repositioning of crew compartment personnel heater) is illustrated and described in paragraph 3-48.

*b. References.*

(1) Checkout and operating instructions are covered in paragraph 3-460 and TM 9-2350-230-20-1.

(2) Repair procedures for coolant heater are presented in paragraph 3-47.

(3) General maintenance procedures are covered in TM 9-2350-230-20-1.

**3-46. Installation of Winterization Kit**

*a. Preliminary Steps.*

(1) Remove engine grilles and battery access door (TM 9-2350-230-20-1).

(2) Remove battery hold-down brackets, batteries, and lead assemblies (TM 9-2350-230-20-1).

(3) *Check vehicle serial number.* Vehicles through serial number 139 do not incorporate mounting blocks for winterization kit coolant heater. To install winterization kits on these vehicles, it will be necessary to fabricate two mounting blocks; weld these blocks on engine compartment center bulkhead above center fuel tank (fig. 3-140); and remove unnecessary block from the turret ring right support post.

(4) Power plant must be removed to gain access for welding mount blocks. When welding is not required, it is possible to install winterization kit without removing power plant. However, kit installation can be accomplished more easily if power plant is removed. Refer to TM 9-2350-230-20-1 for power plant removal and installation instructions.

(5) When power plant is left installed, remove coolant fan upper right shroud, upper shroud seal retainer, and seal with screws and washers from power plant. Turret bearing access cover may also be removed to facilitate kit installation.

(6) Drain engine coolant (TM 9-2350-230-20-1).

(7) Early production vehicles do not have fuel tank fittings arranged to allow installation of winterization kit fuel hose. Refer to figure 3-144 and determine if fuel shutoff valve 8678328 is in vertical position. If valve is in horizontal position drain fuel tanks, remove valve and elbow, and reinstall shutoff valve in vertical position (also refer to *f* below).

**NOTE**

During installation of coolant hoses, fittings, and components, apply sealing compound 8030-00-999-3895 to all male pipe threads being careful to avoid contamination of internal system.

*b. Assembly and Installation of Coolant Heater Mounting Brackets and Exhaust Pipe Brackets (figs 3-139 and 3-141).*

(1) Attach left cradle bracket (60) to heater left bracket (58) using two screws (59) and four snubbing washers (54). Snubbing washers are to be assembled on both sides of shock mounts.

(2) Attach exhaust pipe bracket (53) to heater left bracket (58), securing with two washers (52) and two nuts (51).

(3) Install assembled left cradle bracket, heater left bracket, and exhaust pipe bracket on engine compartment bulkhead using two screws (2) and two washers (47).

(4) Install exhaust pipe roof bracket (5) to underside of engine compartment roof plate using two screws (4) and two washers (3).

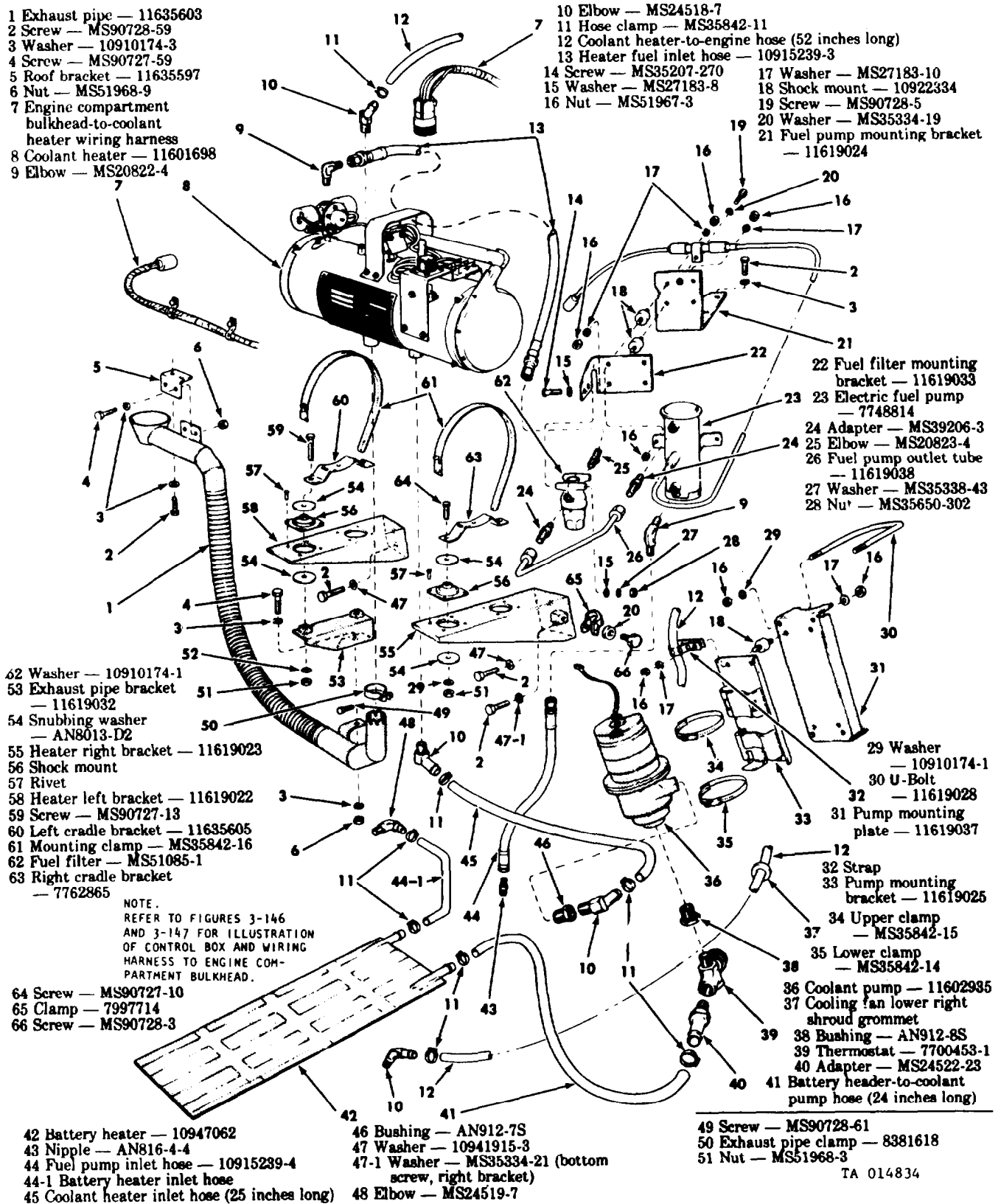

Figure 3-139. Winterization kit - exploded view.



(5) Install one end of exhaust pipe (1) on roof bracket (5) using two screws (4), two washers (3), and two nuts (6). Install other end of exhaust pipe loosely on assembled heater left bracket group (step 3) using screw (4), two washers (3), and nut (6).

(6) Assemble screw (49) in clamp (50) and slip assembly over end of exhaust pipe.

(7) Attach right cradle bracket (63) to heater right bracket (55) using two screws (64), two washers (29), two nuts (51), and four snubbing washers (54). Snubbing washers are to be assembled on both sides of shock mounts.

(8) Install heater right bracket (55) on engine compartment bulkhead using two screws (2), washer (47), and washer (47-1).

*c. Assembly and Installation of Fuel Filter, Fuel Pump, and Mounting Brackets figs. 3-139 and 3-142).*

(1) Install adapter (24) in inlet port and elbow (25) in outlet port of fuel filter (62).

(2) Install fuel filter on mounting bracket (22) using two screws (14), two washers (27), four washers (15), and two nuts (28).

(3) Install coolant heater fuel inlet hose (13) on fuel filter outlet port elbow ((1) above).

(4) Install elbow (9) in inlet (lower) port and adapter (24) in outlet (upper) port of electric fuel pump (23).

(5) Install four shock mounts (18) on fuel pump mounting bracket (21) using four washers (17) and four nuts (16).

(6) Install assembled fuel filter and mounting bracket ((2) above) on shock mounts and fuel pump on upper two shock mount studs extending through fuel filter mounting bracket. Secure assembly using two washers (17) (on lower studs) and four nuts (16).

(7) Install fuel pump outlet tube (26) on adapters in fuel pump and fuel filter and tighten fittings.

(8) Install assembled pump and filter assembly ((1) through (7)) on tapping blocks on center fuel tank (fig. 3-140) using three washers (3) and three screws (2).

*d. Assembly and Installation of Coolant Pump and Mounting Bracket (figs. 3-139 and 3-143)*

(1) Install bushing (46) and elbow (10) in outlet port of coolant pump (36).

(2) Install bushing (38), thermostat (39), and adapter (40) in inlet port of coolant pump (36).

(3) Install four shock mounts (18) on pump mounting plate (31) using four washers (17) and four nuts (16).

(4) Install pump mounting bracket (33) on mounting plate (31) and shock mounts (18). Assemble approximate 6-inch length of strap (32) (sufficient to retain 1 inch OD coolant hose) on upper shock mount stud. Secure bracket to plate with four washers (17) and four nuts (16).

(5) Install coolant pump (36) on assembled mounting bracket and mounting plate and secure with upper clamp (34) and lower clamp (35).

(6) Install assembled coolant pump and mounting, bracket and plate on turret ring right support post, with thermostat to support post with two U-bolts (30), four washers (29), and four nuts (16).

*e. Assembly and Installation of Coolant Heater (figs. 3-139 and 3-144).*

(1) Install elbow (9) in top of heater fuel control valve.

(2) Install two elbows (10); one in inlet port (bottom) and one in outlet port (top) of coolant heater (8). Flame detector switch guard must be removed to install elbow in top outlet port.

(3) Place clamp (11) over one end of 5/8-inch ID x 25 inches coolant inlet hose, install hose on heater bottom elbow and tighten clamp securely.

(4) Position heater two mounting clamps (61) through openings in heater cradle brackets. Place coolant heater (8) on mounting brackets, routing attached coolant inlet hose under heater right mounting bracket and in front of fuel pump, towards coolant pump outlet fitting. Position heater to align exhaust outlet with exhaust pipe (1) (installed in b above) and insert outlet into pipe. Secure heater mounting clamps but do not completely tighten.

(5) Tighten screw (4) to secure exhaust pipe (1) to bracket (5) (installed in b above).

(6) Securely tighten two clamps (61) to retainer heater in mounting brackets.

(7) Position and tighten screw in exhaust pipe clamp (50) (b(6) above), to secure exhaust pipe to heater.

(8) Pass free end of fuel hose (13) (see c(3) above) under flame detector switch guard and then connect hose to elbow on coolant heater fuel control valve and tighten fittings on heater and fuel filter.

*f. Installation of Fuel Hoses (figs. 3-139 and 3-144).*

(1) Remove plug MS49005-4 for fuel shutoff valve 8678328 at bottom of center fuel tank and install nipple (43).

(2) Install one end of fuel pump inlet hose (44) at fuel shutoff valve nipple and other end at inlet elbow of fuel pump (23).

(3) Coolant heater fuel inlet hose (13) connecting coolant heater and fuel filter were previously installed. Refer to c(3) and e(8), above.

(4) Open fuel shutoff valve at bottom of center fuel tank.

*g. Installation of Battery Heater (figs. 3-139 and 3-145).*

(1) Remove blank grommet from battery insulation at front of battery compartment.

(2) Place battery heater (42) through battery access door with flat side up. During replacement of

heater, guide inlet tube through hole in insulation (blank grommet location) and final position heater on battery tray.

(3) Remove four screws and remove cover 2590-00-159-8892 from battery compartment vent tube inlet. Turn cover 180 degrees and reinstall to seal vent tube inlet.

*h. Installation of Coolant Heater Control Box (figs. 3-146 and 3-147).* Attach coolant heater control box 2590-01-125-6154 to bracket on hull upper left plate in driver's compartment, opposite personnel heater control box, using two washers 5310-00-821-6269 and two nuts 5310-00-905-0762.

*i Deleted.*

*j. Deleted.*

*k. Installation of Coolant Hoses (figs. 3-139 and 3-148).*

(1) Place one clamp (11) at each end of  $\frac{5}{8}$ -inch ID x 24 inches long hose. Connect one end of hose to battery heater (42) outlet and other end to coolant pump inlet adapter (40, d(2) above). Tighten clamps.

(2) Place clamp (11) over free end of 25-inch long coolant inlet hose (installed to coolant heater bottom elbow in A, figure 3-144). Route hose in front of fuel pump bracket on top of fuel tank, connect hose to coolant pump elbow and tighten clamp.

(3) Remove plug 4730-00-289-5176 from engine crossover tube at right cylinder bank location and install elbow (48) in its place.

(4) Remove plug MS201919-45 from engine-to-radiator tube and install elbow (43) in its place.

(5) Place one clamp (11) over one end of  $\frac{1}{2}$ -inch ID x 52-inch long coolant hose. Position this end of hose on engine-to-radiator tube elbow (48) and tighten clamp.

(6) Place clamp (11) over one end of  $\frac{5}{8}$ -inch ID x 25-inch long coolant hose. Position this end of hose on engine crossover tube elbow (48) at right cylinder bank location and tighten clamp.

(7) Remove solid grommet 5325-00-919-6467 from cooling fan lower right shroud and replace with grommet 5325-00-174-9341.

#### NOTE

If power plant has been removed during preceding installation steps, install power plant at this point (refer to TM 9-2350-230-20-1) and continue with winterization kit installation.

(8) Place clamp (11) on free end of  $\frac{1}{2}$ -inch 10 x 25-inch long coolant hose (engine crossover tube location), install on battery heater (42) inlet tube and tighten clamp.

(9) Insert free end of 52-inch coolant hose previously connected to engine-to-radiator tube elbow ((5), above) through grommet 5325-00-174-9341 in cooling fan lower right shroud. Route hose upward through strap (32) previously installed on coolant pump bracket (33, d(4) above). Place clamp (11) on free end of hose, connect hose to coolant heater outlet port elbow (48, d(1) above), and tighten clamp.

*l. Installation of Shroud and Batteries (fig. 3-145).*

(1) If power plant was left installed during kit installation, coolant fan upper right shroud, upper shroud seal, and seal retainer were removed for clearance. Reinstall these components (TM 9-2350-230-20-1).

(2) Install batteries, hold-down brackets, and leads (TM 9-2350-230-20-1).

*m. Filling and Bleeding Procedure.*

**NOTE**

After refilling engine and heater coolant system to full level in accordance with vehicle arctic preparation procedures, an air bleed must be performed on kit and engine coolant system to avoid coolant heater malfunction and possible failure. Air bleed should also be performed after reinstallation of coolant heater or coolant lines removed from coolant system.

(1) Before refilling engine and heater coolant system, disconnect  $\frac{5}{8}$ -inch ID x 52-inch long hose from elbow 4730-00-917-6781 at heater 2990-00-997-1532 outlet side (top).

(2) Fill engine and heater coolant system until coolant spills from hose and heater elbow.

(3) With caution, reinstall  $\frac{1}{2}$ -inch ID x 52-inch long hose on elbow 4730-00-917-6781 at heater 11601698 outlet side and secure with clamp. Do not allow air to enter hose or elbow.

(4) Complete filling coolant system to full level as indicated on surge tank.

**NOTE**

The coolant pump can be operated to aid air-bleed procedure by electrically connecting pump to vehicle-installed batteries with a jumper wire.

**CAUTION**

Connect battery positive terminal to lead labeled 565 on coolant pump.

n. Deleted.

o. *Checkout and Operating Instructions.*

(1) *General.* Winterization kit is operated upon engine shutdown in ambient temperatures between -25°F. and -65°F. to maintain elevated engine sump, engine coolant and battery electrolyte temperatures. Time duration winterization kit can be operated as dependent upon battery capacity. Care should be taken not to operate other vehicle electrical equipment while kit is in operation. Winterization kit operation can be initiated in temperatures as low as -65°F. However, 3 to 5 hours of kit operation are requested prior to attempting an engine start of a cold soaked vehicle.

(2) *Use of grille cover.* Before starting coolant heater, unfasten heater exhaust pipe cover and secure in open position. Before starting engine, unfasten three or five straps on exhaust grille cover and roll cover into smallest possible tube form securing straps onto unused spacers on forward end of exhaust grille. Also, unfasten two or four straps on engine intake grille cover, roll cover into smallest possible tube form and secure straps onto spacers installed on bracket 10955641. Grille cover should be removed entirely and stowed during prolonged engine operations or during main weapon firing.

(3) *Operating procedures*

**NOTE**

The coolant heater should be started on low heat. Heater should then be switched to high heat 10 minutes after indicator lamp on control box has illuminated. The heat selector switch should remain in high heat position during prolonged use of winterization kit and coolant thermostat (5930-00-808-2941) will automatically switch heater from high to low heat thereby maintaining proper system temperatures. Heater may be operated with vehicle master switch in "ON" or "OFF" position. It is recommended that "OFF" position be used to minimize battery drain.

**WARNING**

Make certain grenade projectors are out of mounts during operating of winterization kit. Coolant heater exhaust may damage or cause malfunction of projectors.

(a) Depress *indicator light*. Lamp will illuminate if electricity is available.

**NOTE**

If indicator lamp does not illuminate, replace lamp and/or determine cause for lack of electrical continuity.

(b) Place heat selector switch to "LOW" position.

(c) Hold heat control switch in "START" position until indicator lamp illuminates (1 to 3 minutes).

(d) Snap heat control switch to "RUN" position.

**CAUTION**

If indicator lamp does not illuminate within 3 minutes, turn control switch to "OFF" position and wait 5 minutes. Repeat (c) and (d) above, to make a second attempt to start heater. If the heater does not start after a third attempt, turn control switch to "OFF" position and troubleshoot system.

(e) Switch heat selector switch to "HI" position 5 to 10 minutes after indicator lamp has illuminated.

(f) *Stopping heater*. Place heat control switch to center "OFF" position. Indicator lamp will remain illuminated and blower will continue to run for 2 or 3 minutes until combustion chamber has been purged.

**3-47. Repair of Coolant Heater**

a. *Repair of Coolant Heater*. Refer to figure 3-150.

b. *Repair of Coolant Heater Blower*. Refer to figure 3-151.

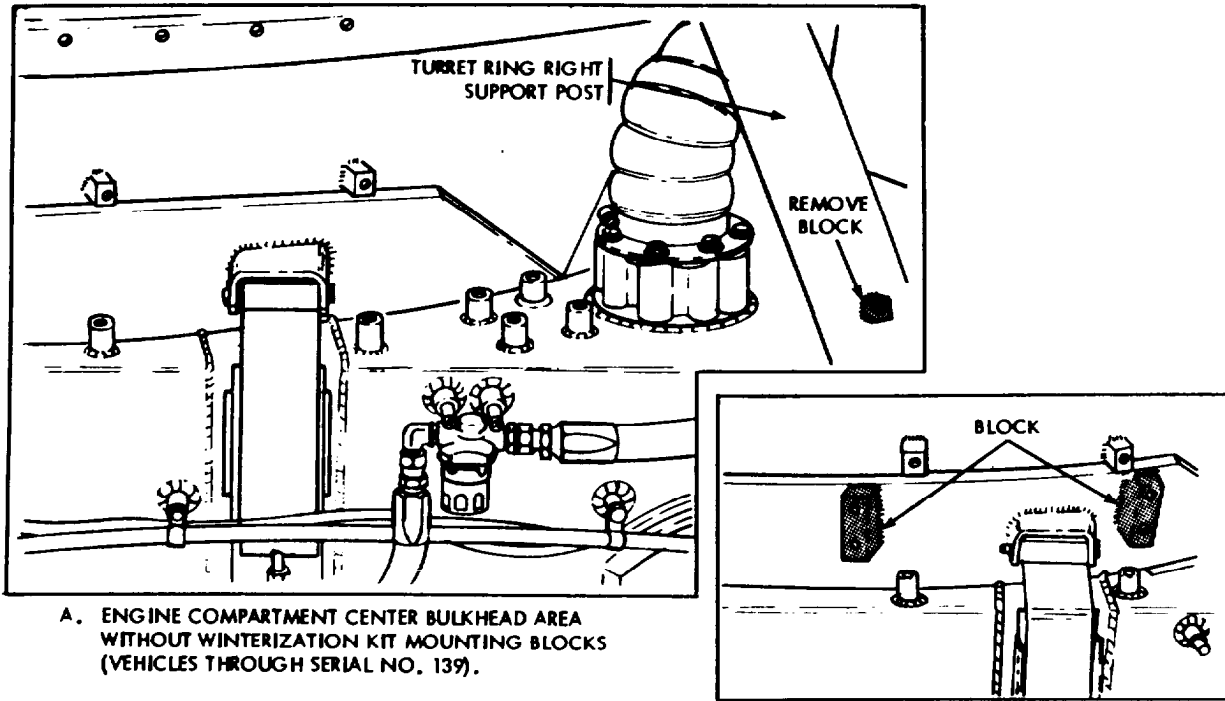

A. ENGINE COMPARTMENT CENTER BULKHEAD AREA WITHOUT WINTERIZATION KIT MOUNTING BLOCKS (VEHICLES THROUGH SERIAL NO. 139).

B. MOUNTING BLOCKS ADDED.

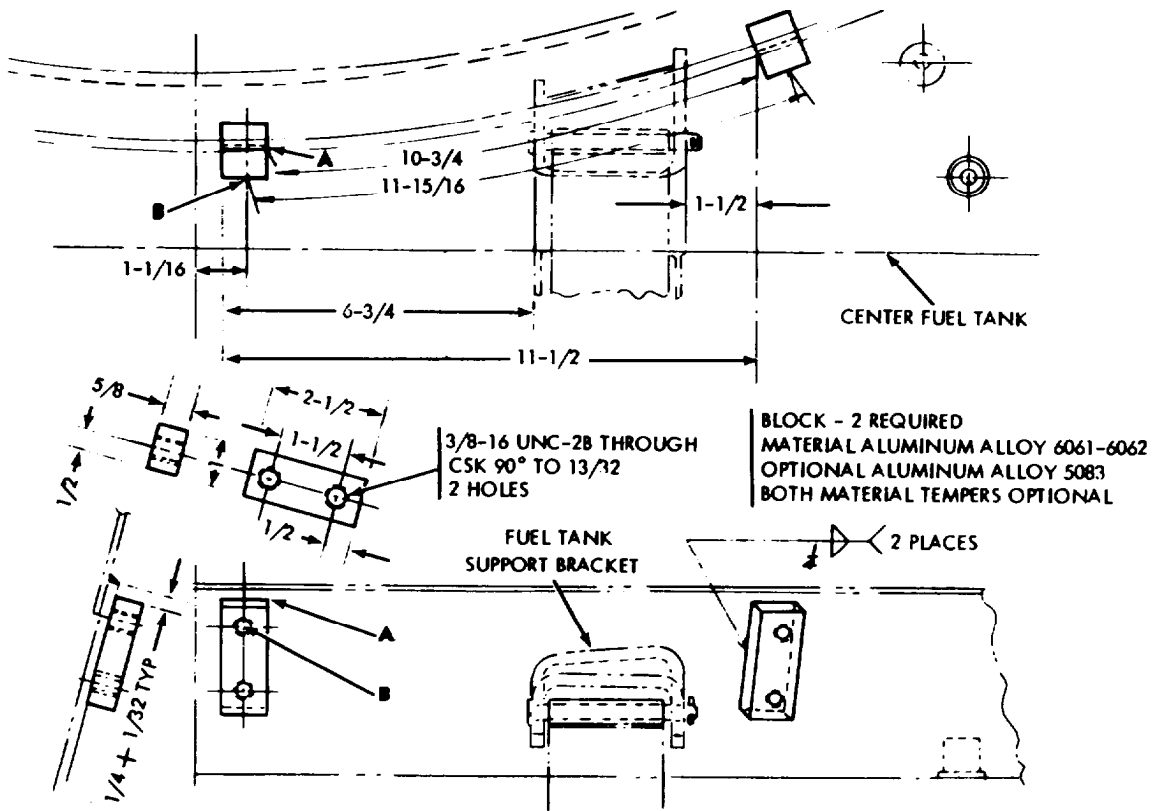

C. LOCATIONAL DETAIL FOR MOUNTING BLOCKS.

ORD E70546

Figure 3-140 Installation, winterization kit (1 of 10).

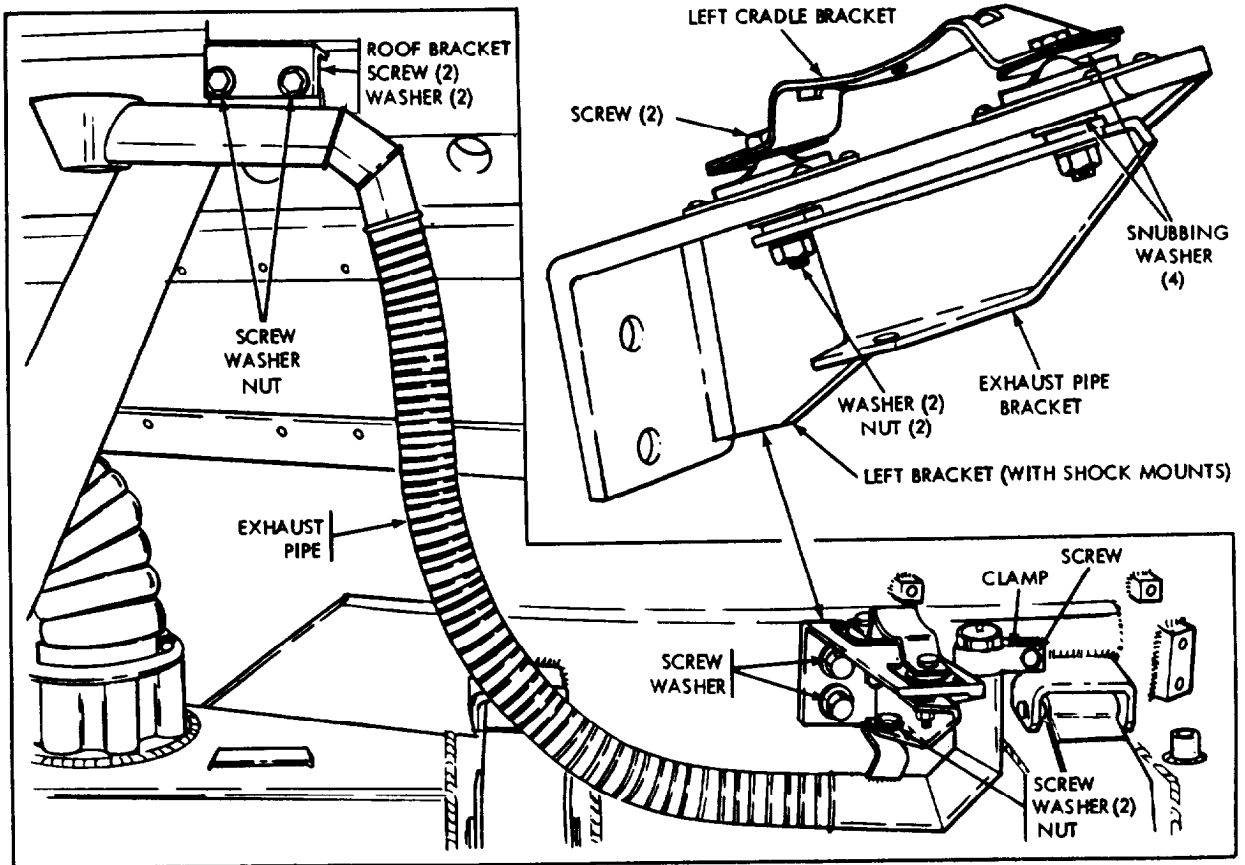

A. ASSEMBLE AND INSTALL COOLANT HEATER LEFT CRADLE BRACKET, LEFT BRACKET, AND EXHAUST PIPE.

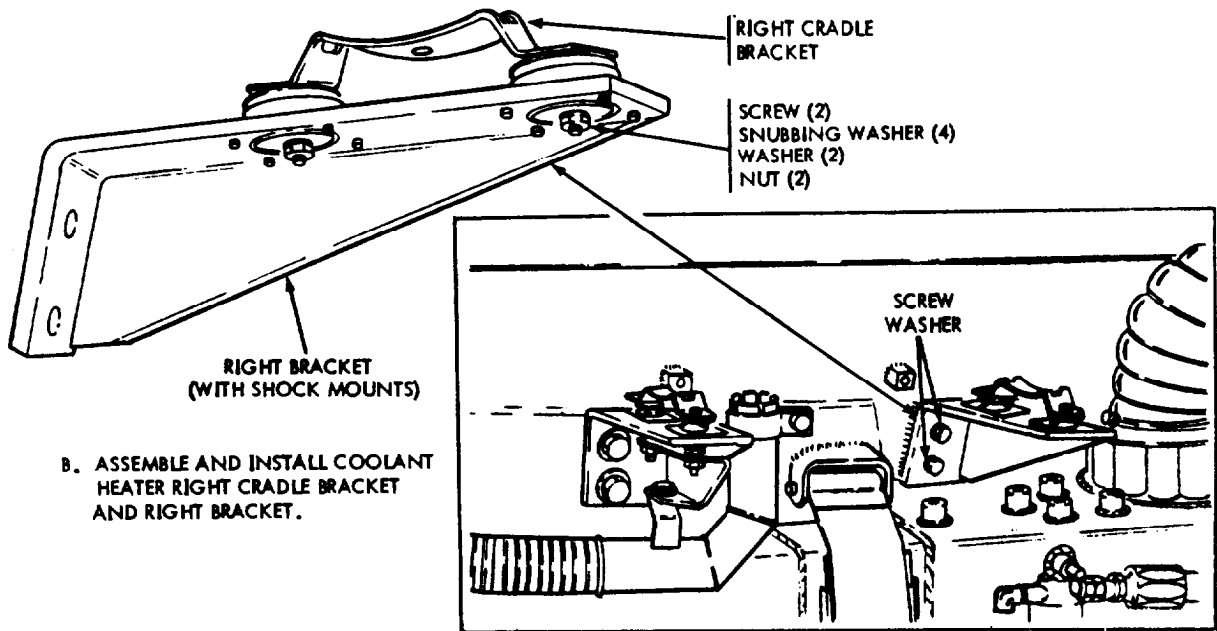

B. ASSEMBLE AND INSTALL COOLANT HEATER RIGHT CRADLE BRACKET AND RIGHT BRACKET.

ORD E70547

Figure 3.141. Installation of winterization hit (2 of 10).

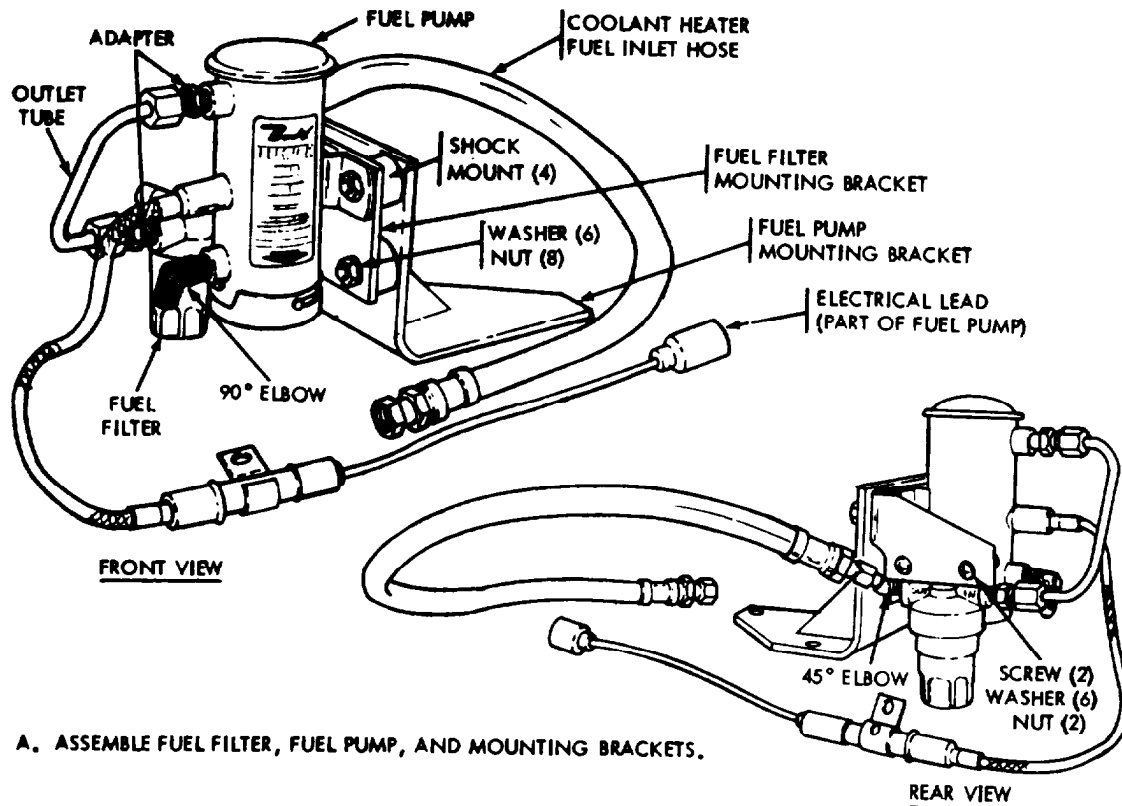

A. ASSEMBLE FUEL FILTER, FUEL PUMP, AND MOUNTING BRACKETS.

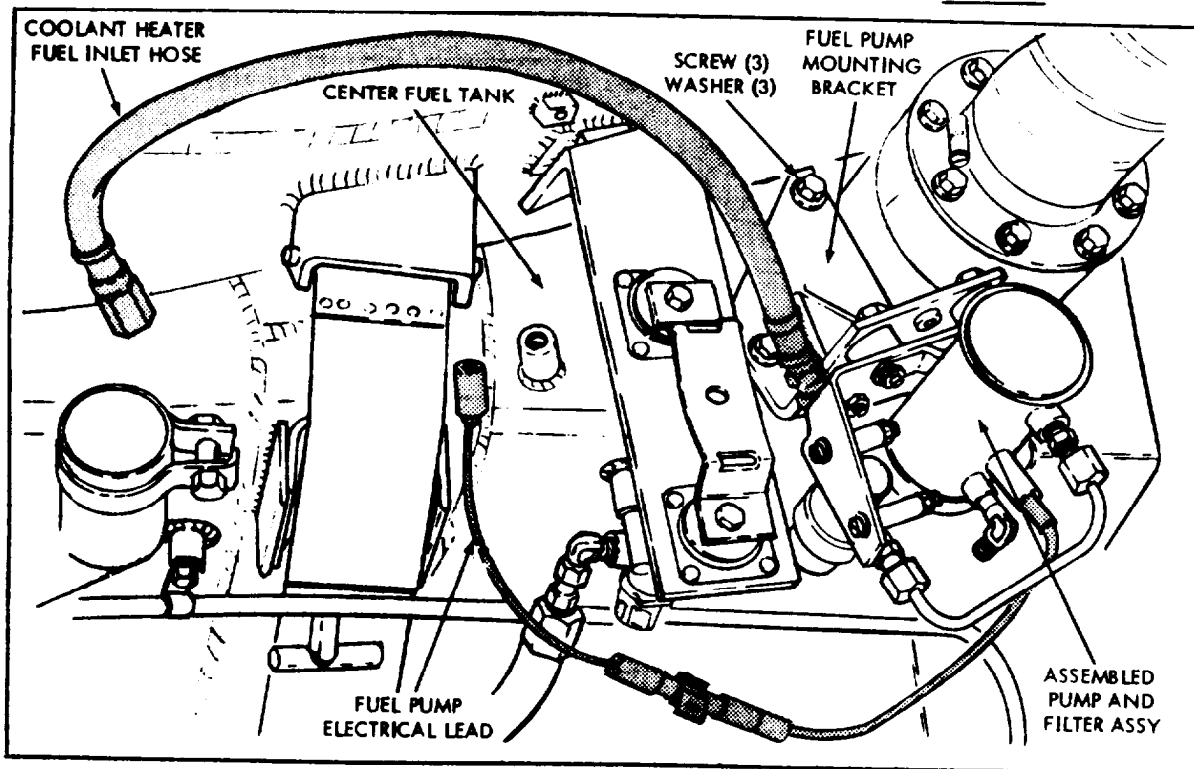

B. INSTALL ASSEMBLED FUEL FILTER, FUEL PUMP, AND MOUNTING BRACKETS.

ORD E70548

Figure 3-142. Installation of winterization kit (3of10).

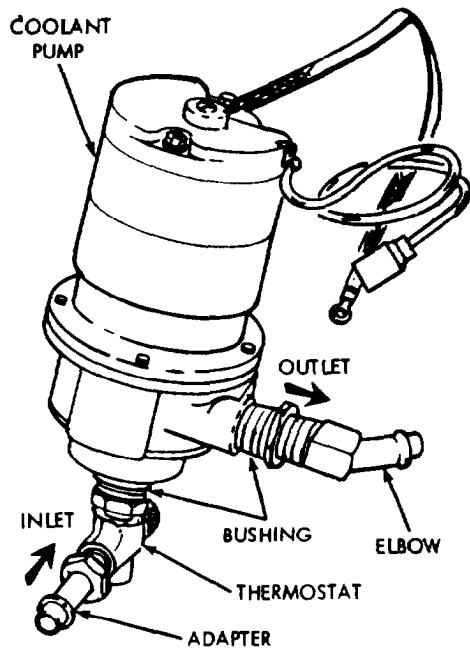

A. ASSEMBLE COOLANT PUMP.

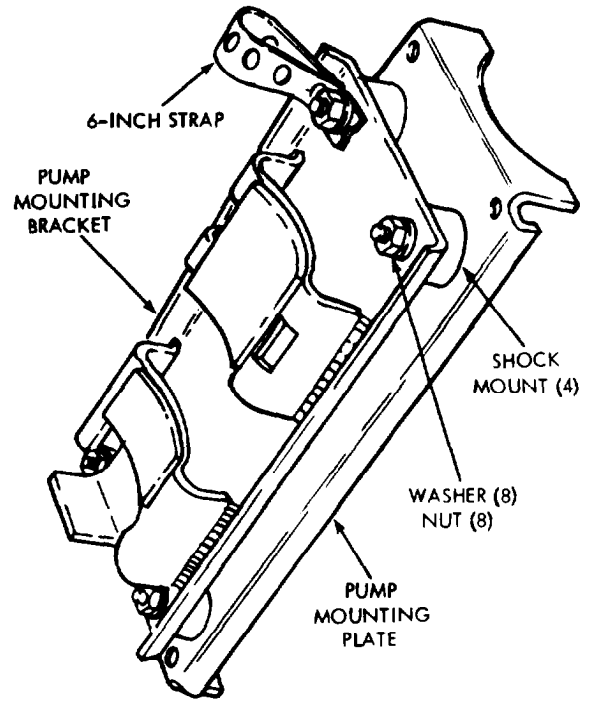

B. ASSEMBLE COOLANT PUMP MOUNTING BRACKET AND MOUNTING PLATE.

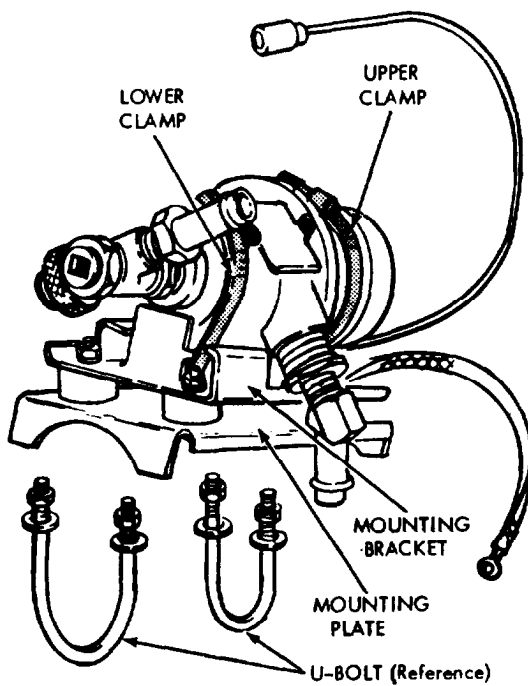

C. INSTALL COOLANT PUMP ON ASSEMBLED MOUNTING BRACKET AND MOUNTING PLATE.

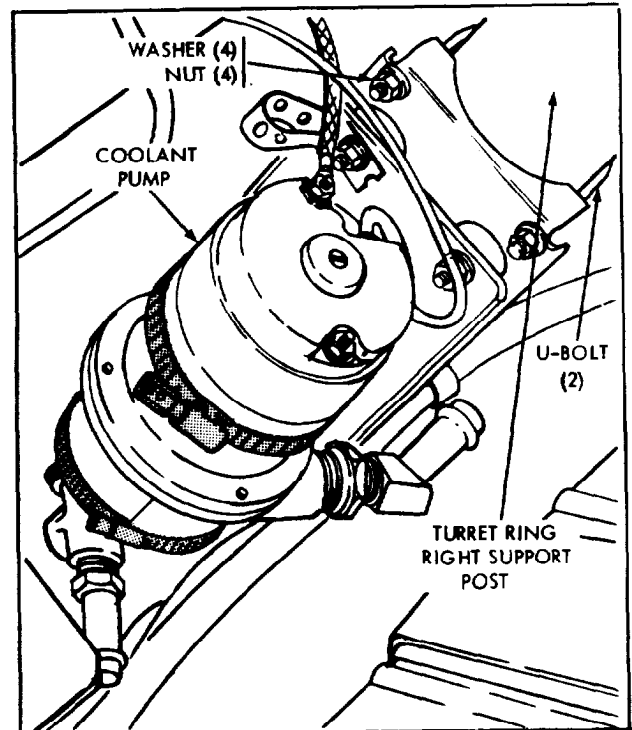

D. INSTALL ASSEMBLED COOLANT PUMP, AND MOUNTING BRACKET AND PLATE, ON TURRET RING RIGHT SUPPORT POST.

ORD E70549

Figure 3-143. Installation of winterization hit (4 of 10).



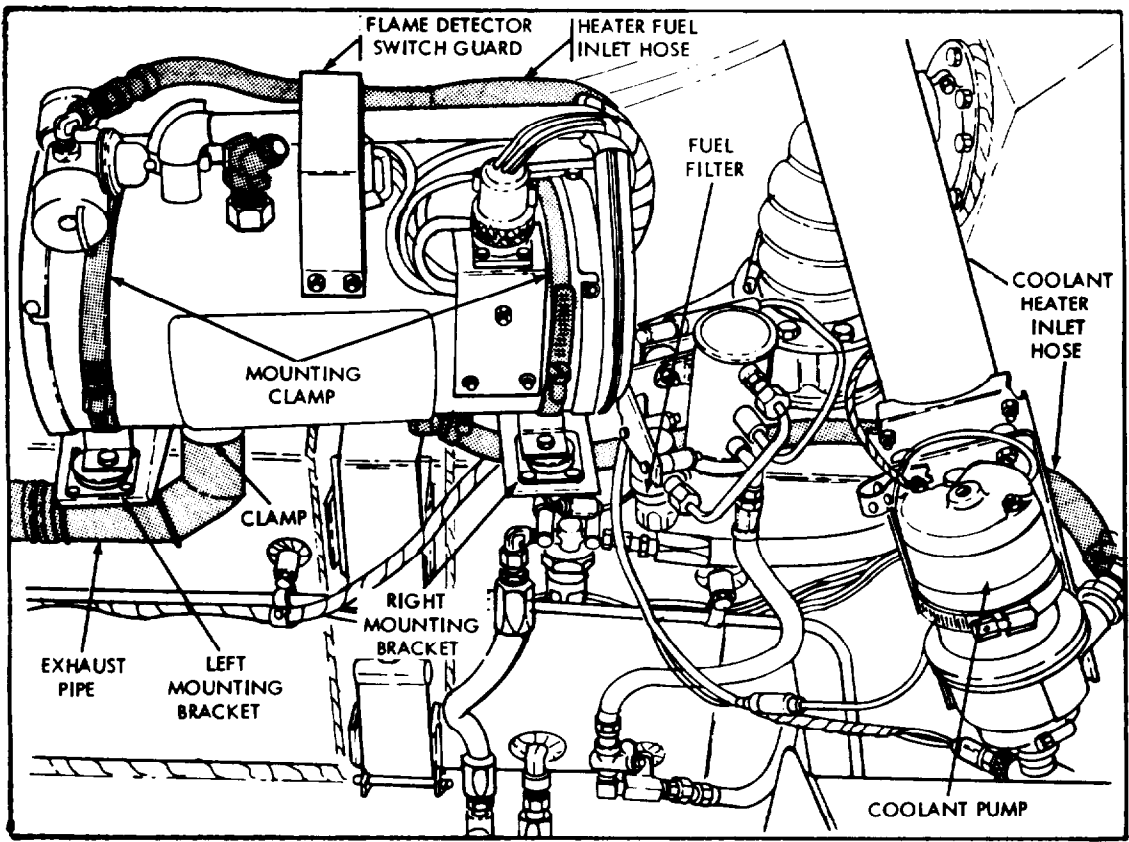
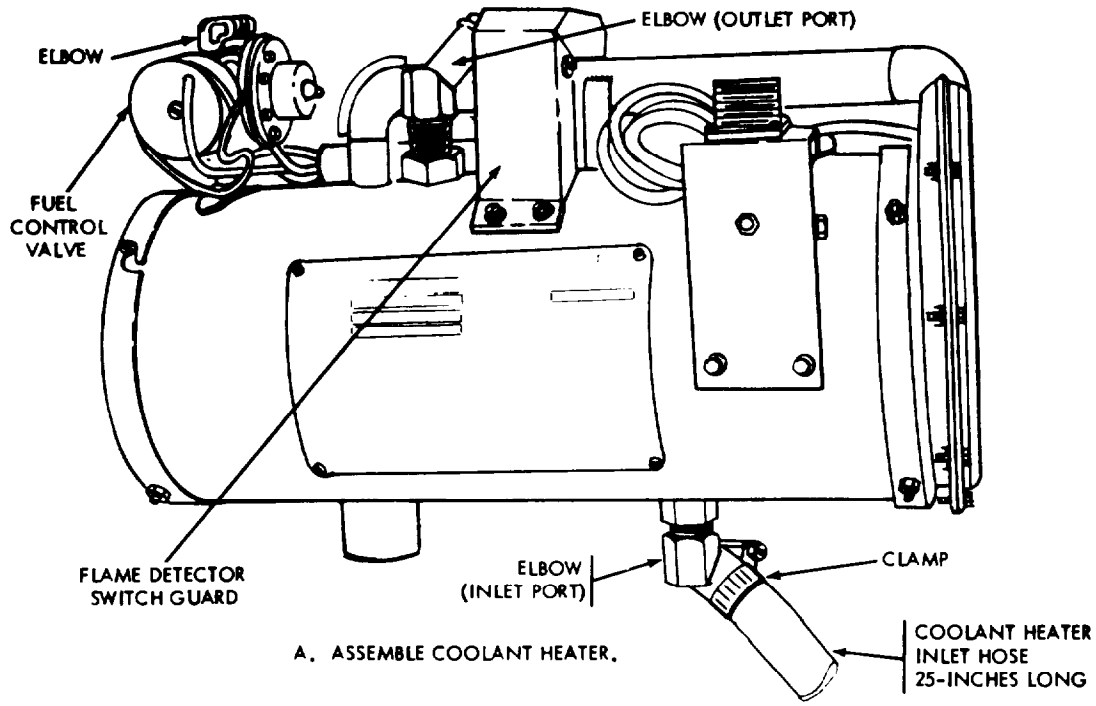

ORD E70550

Figure 3-144. Installation of winterization hit (5 of 10).

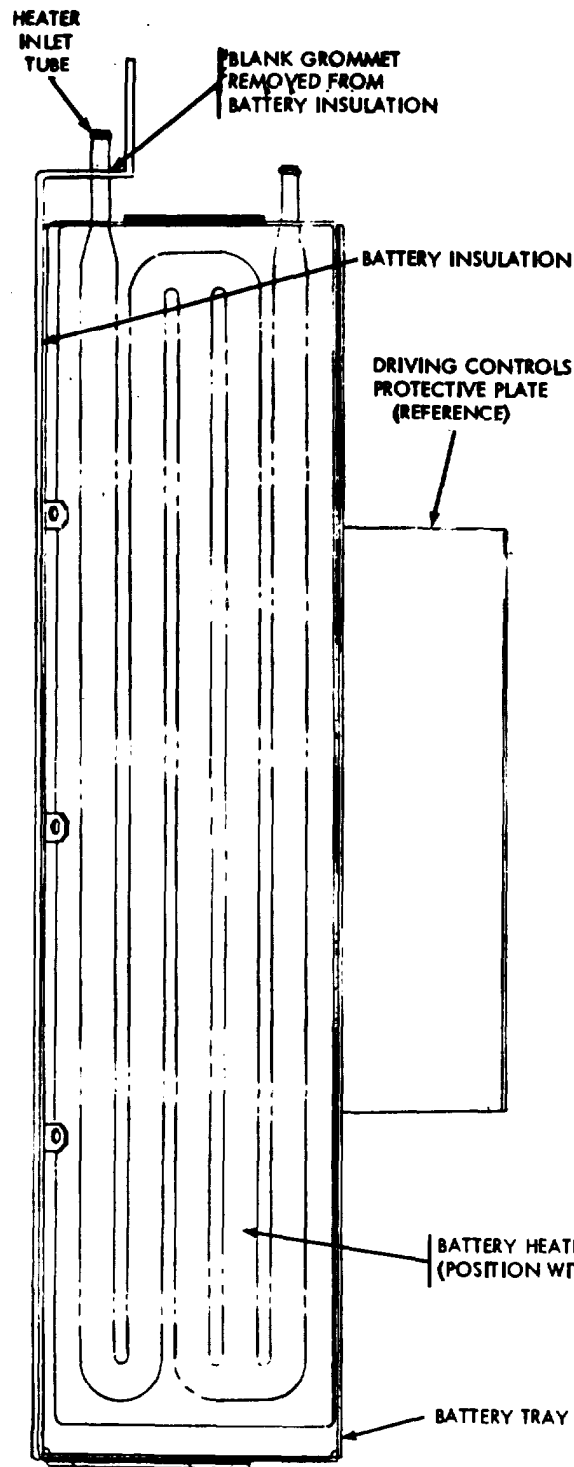

A. INSTALL HEATER ON BATTERY TRAY.

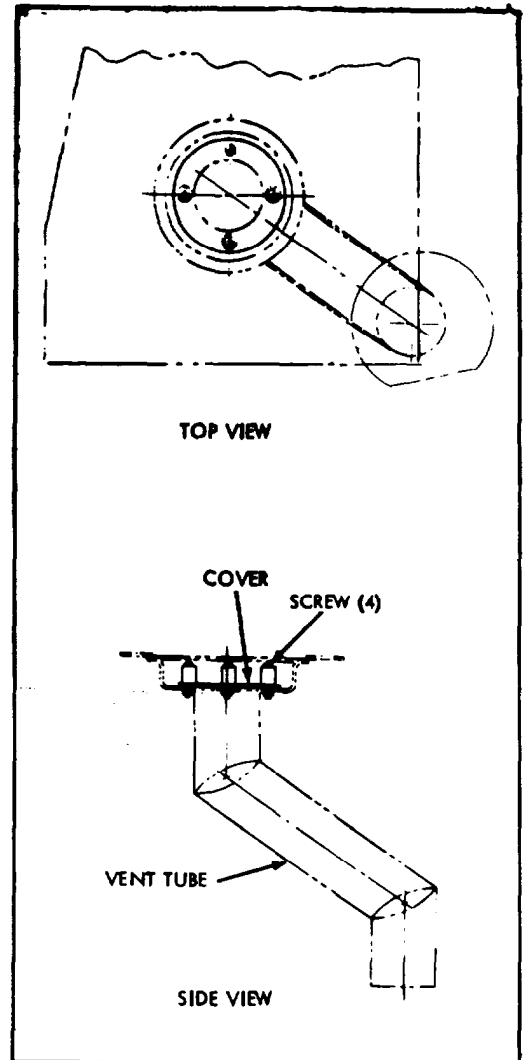

B. TURN BATTERY COMPARTMENT VENT TUBE INLET COVER 180° FROM VENTED TO CLOSED POSITION.

ORD E70551

Figure 3-145. Installation of winterization hit (6 of 10)

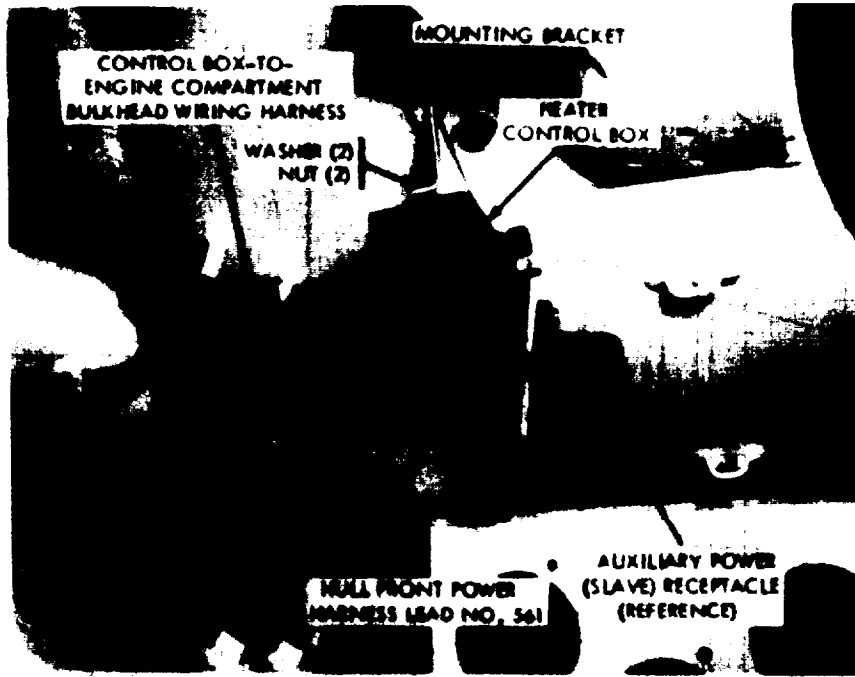

A. INSTALLATION OF COOLANT HEATER CONTROL BOX.

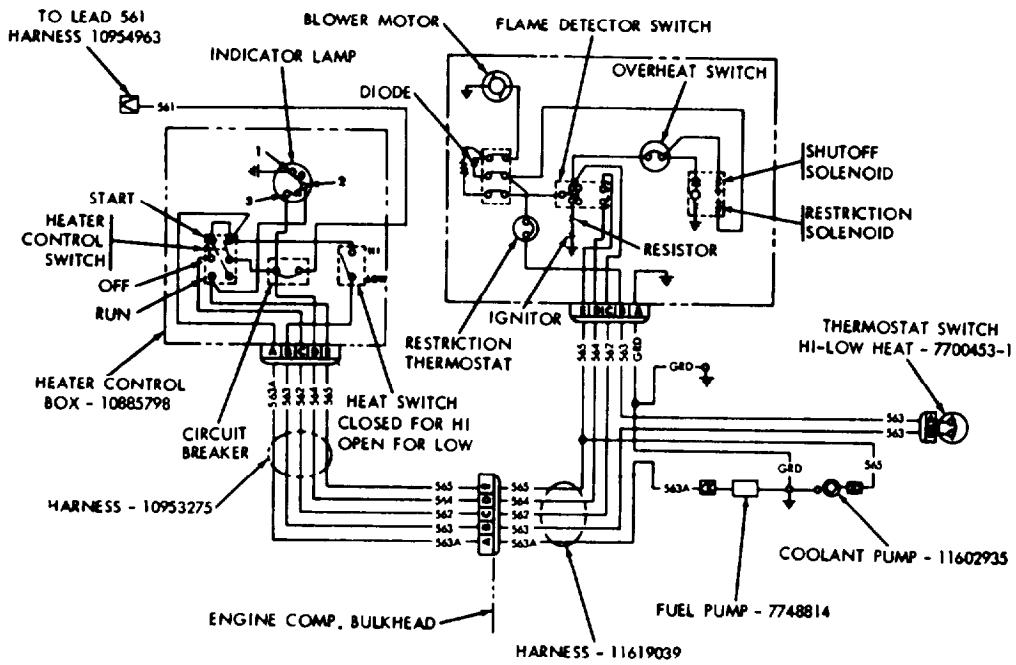

B. WINTERIZATION KIT ELECTRICAL WIRING DIAGRAM.

ORD E70552

Figure 3-146. Installation of winterization hit (7 of 10)

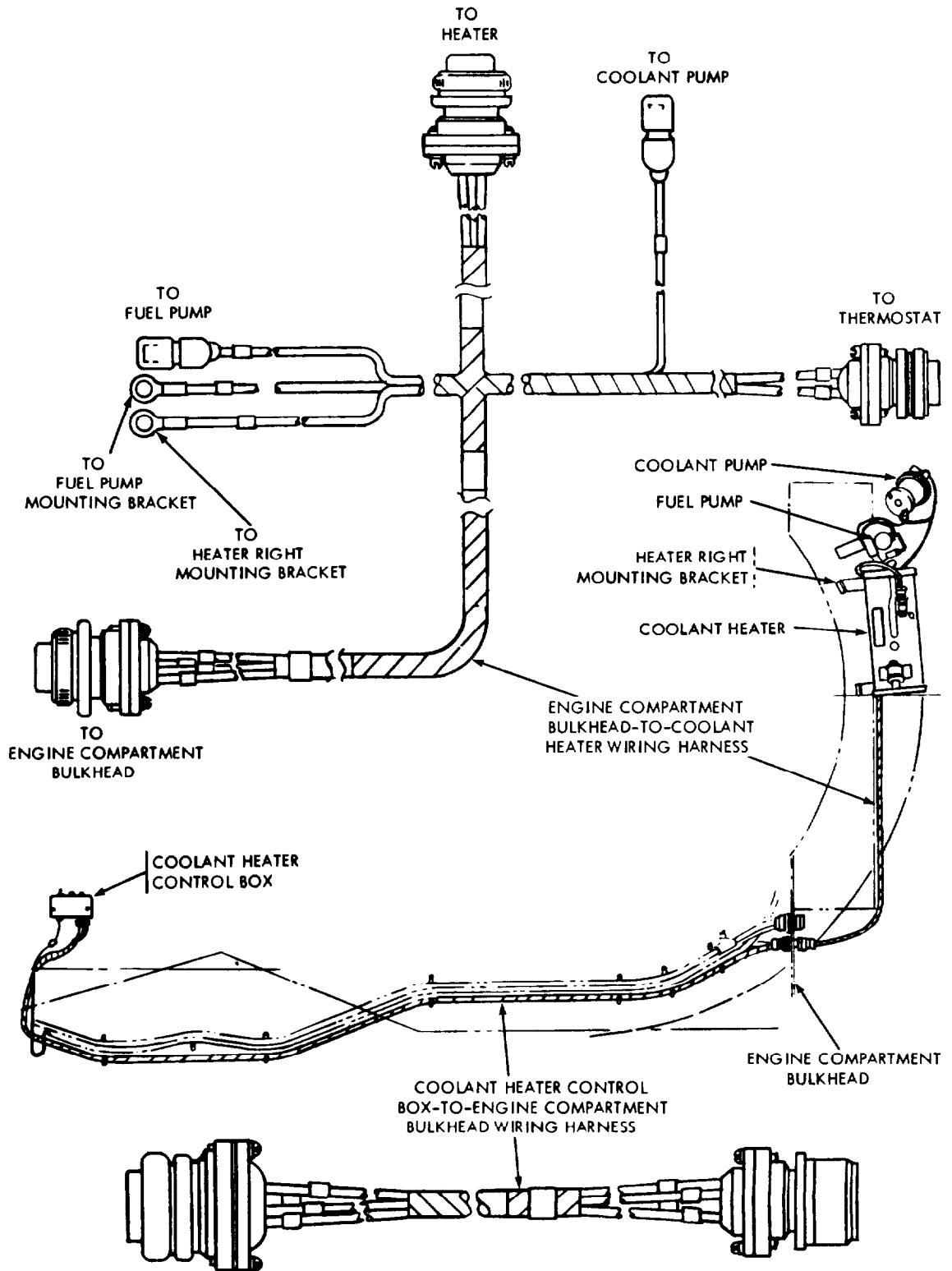

ORD E70553

Figure 3-147. Installation of winterization kit (8 of 10).

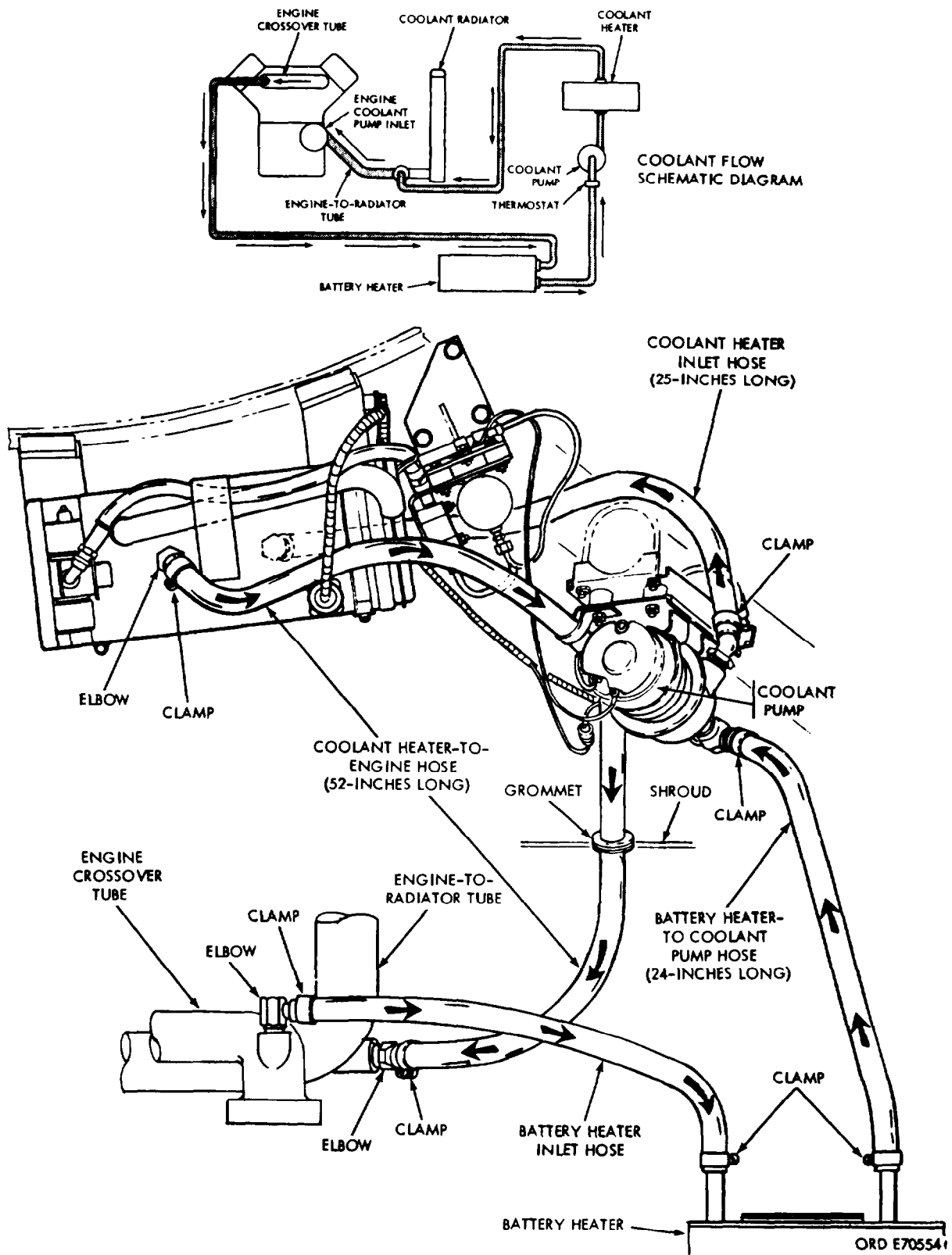
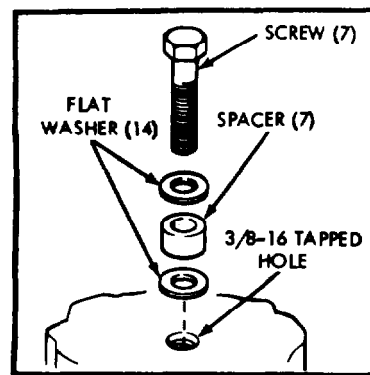
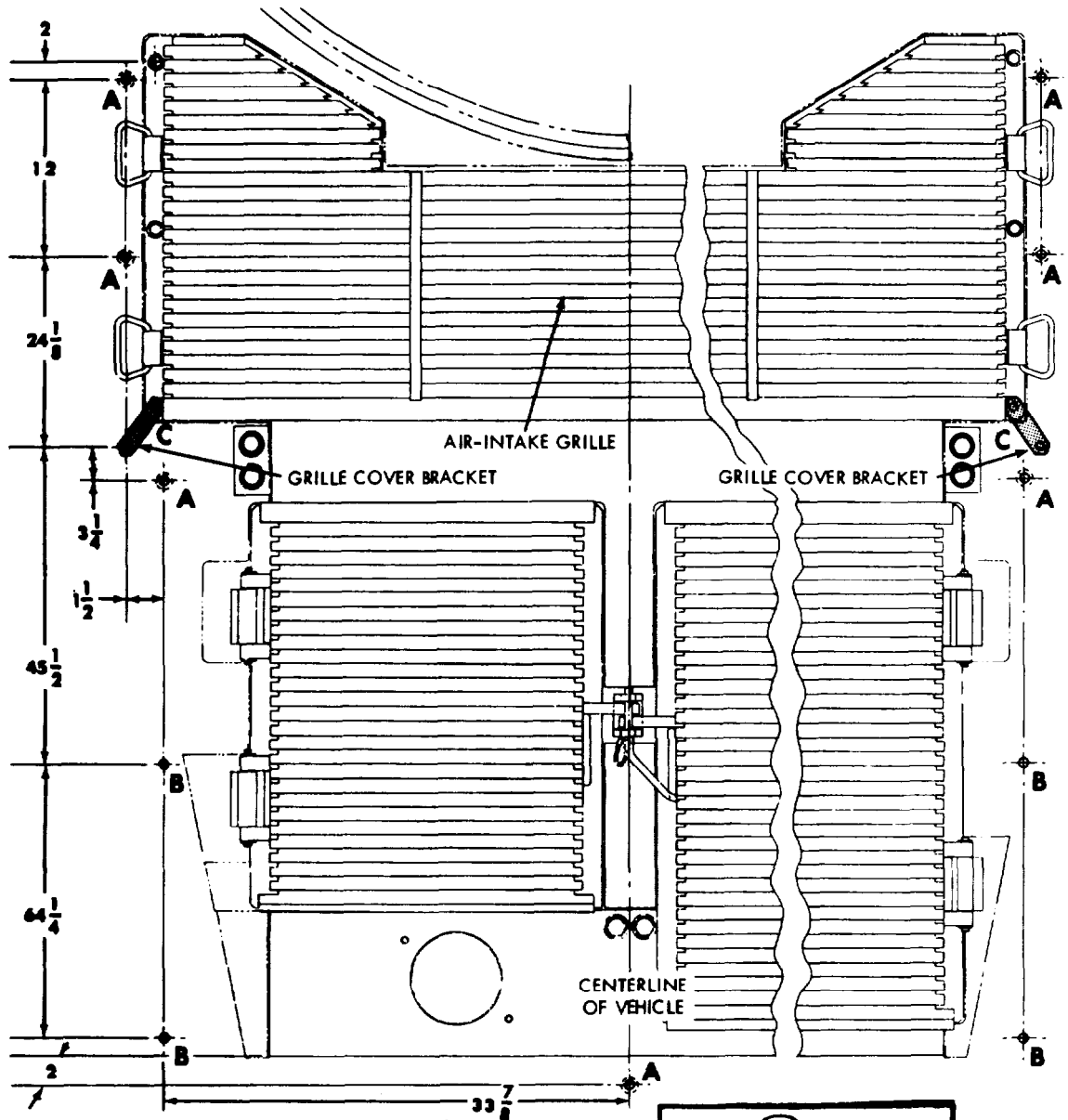

Figure 3-148. Installation of winterization kit (9 of 10).



**A** GRILLE COVER RETAINING METHOD (7 LOCATIONS)

PROCEED AS IN "B" AND ASSEMBLE SCREW, WASHERS, SPACER, BRACKET, AND NUT. INSTALL AT REAR OF INTAKE GRILLE AT 2 LOCATIONS.

REFER TO ITEMS 7 AND 8 IN PARAGRAPH 3-46n.

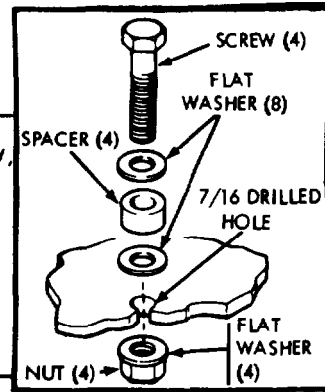

**B** GRILLE COVER RETAINING METHOD (4 LOCATIONS)

TA 014835

Figure 3-149 Installation of winterization hit (10 of 10)

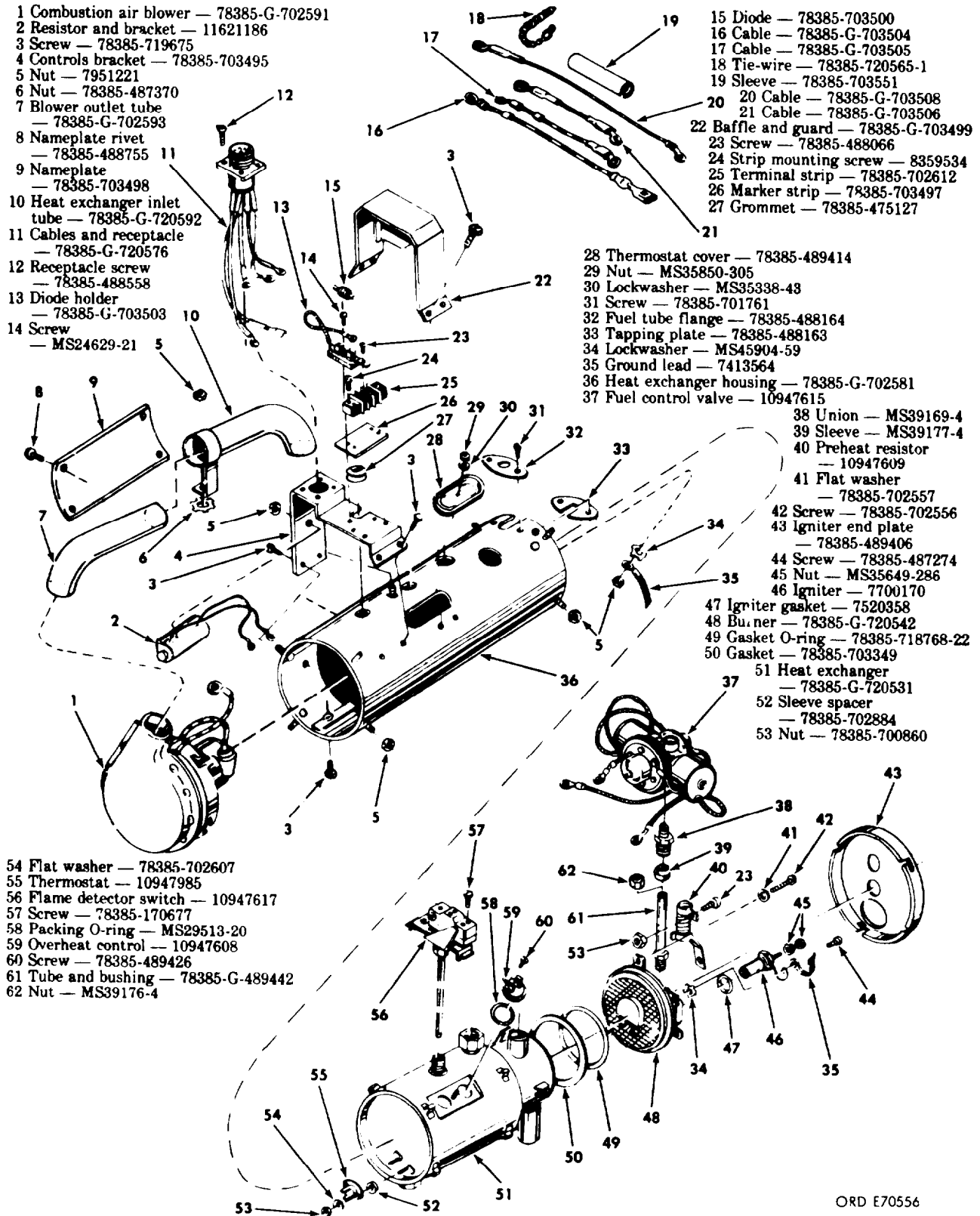

Figure 3-150. Disassembly/assembly of winterization hit coolant heater-11601698.

ORD E70556

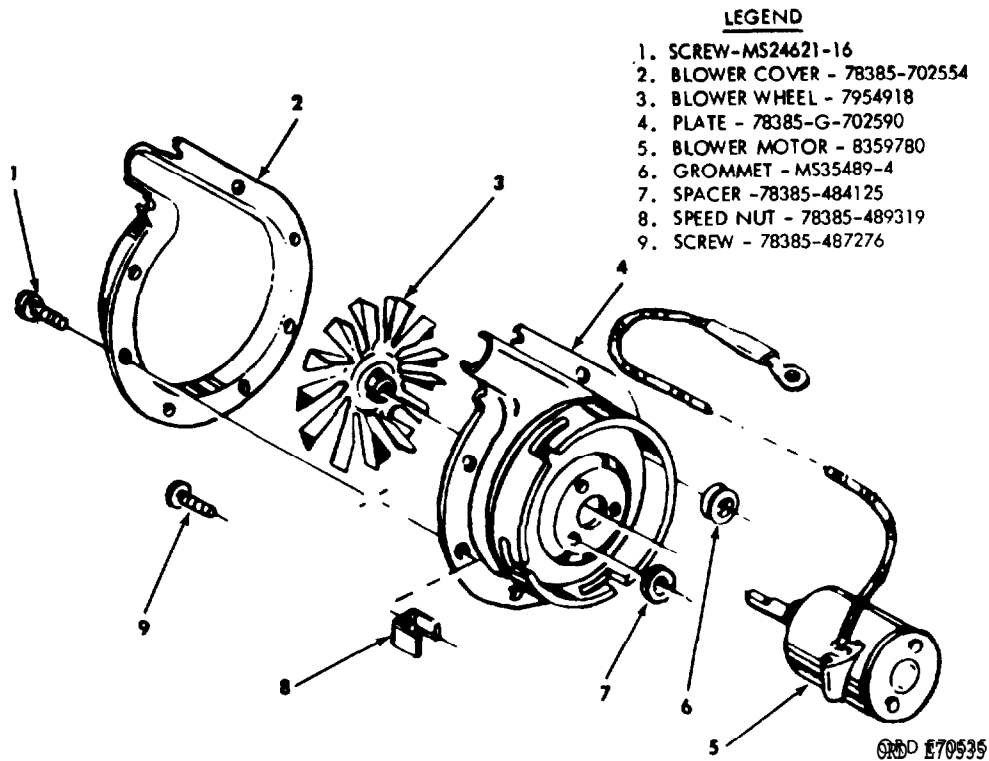

Figure 3-151. Disassembly/assembly of winterization hit coolant heater combustion air blower.

**3-48. Installation of Late Winterization Kit 11678893 (Includes Repositioning of Crew Compartment Personnel Heater)**

*a Preliminary Steps.*

- (1) Remove power plant (TM 9-2350-230-20-1).
- (2) Remove battery access door, brackets, and batteries (TM 9-2350-230-20-1).
- (3) Remove right fuel tank (fig. 2-7).
- (4) Vehicles through serial number 139 do not have the required two mounting blocks for winterization kit coolant heater. For these vehicles it will be necessary to fabricate and weld these blocks on engine compartment center bulkhead above center fuel tank (fig. 3-140).
- (5) Early vehicles have fuel shutoff valve 8678328 mounted in horizontal position. Remove valve and elbow and reinstall shutoff valve in vertical position (fig. 3-154).

**NOTE**

When installing coolant hoses, fittings, and components, apply sealing compound 8030-00-999-3895 to all male pipe threads being careful to avoid contaminating internal system.

*b. Assembly and Installation of Coolant Heater Mounting Brackets and Front and Rear Exhaust Pipes (figs. 3-152, 3-153, and 3-157).*

- (1) Attach left cradle bracket (10) to heater left

bracket (79) using two screws (9) and four snubbing washers (76). Snubbing washers are to be assembled on both sides of shock mounts. If two shock mounts and bracket have not been preassembled, use eight rivets and complete the assembly.

- (2) Attach exhaust pipe bracket (78) to heater left bracket, securing with two washers (75) and two nuts (74).

(3) Install assembled left cradle bracket, heater, left bracket, and exhaust pipe bracket on engine compartment bulkhead using two screws (6) and two washers (5).

- (4) Install exhaust pipe roof bracket (7) to underside of engine compartment roof plate using two screws (4) and two washers (5).

(5) Install one end of exhaust pipe (3) on roof bracket (7) using two screws (6), two washers (5), and two nuts (8). Install other end of exhaust pipe loosely on assembled heater left bracket group using screw (6), two washers (5), and nut (8).

- (6) Assemble screw (1) in clamp (2) and slip assembly over end of exhaust pipe.

(7) Position rear exhaust pipe bracket (63) under engine compartment roof plate and scribe hole locations. **Drill** two 0.435 (+0.016) holes through plate and install two screws (64), two washers (5), and two nuts (8).

- (8) Machine opening in cooling system left shroud 11593757 (fig. 3-157). Install rear exhaust pipe



11665130 in left shroud by slipping slotted end of pipe through shroud opening from rear. Attach rear exhaust pipe to bracket 11635597 using two screws MS90727-60, two washers 10941915-3, two washers 10910174-3, and nut MS51968-9. Assemble screw MS90728-61 in clamp 8381618-2 and slip assembly over slotted end of exhaust pipe. slip slotted end of rear exhaust pipe 11665130 over end of exhaust pipe 11665129 at engine compartment bulkhead and tighten clamp.

(9) Attach right cradle bracket (11) to heater right bracket (77) using two screws (12), two washers (75),

two nuts (74), and four snubbing washers (76). Snubbing washers are to be assembled on both sides of shock mounts. If two shock mounts and bracket have not been preassembled, use eight rivets and complete the assembly.

(10) Install heater right bracket on engine compartment bulkhead using two screws (4), washer (65), and washer (73).

*c. Assembly and Installation of Fuel Filter, Fuel Pump, and Mounting Brackets (figs. 3-142 and 3-152).*

(1) Install adapter (35) in inlet port and elbow (33) in outlet port of fuel filter (34).

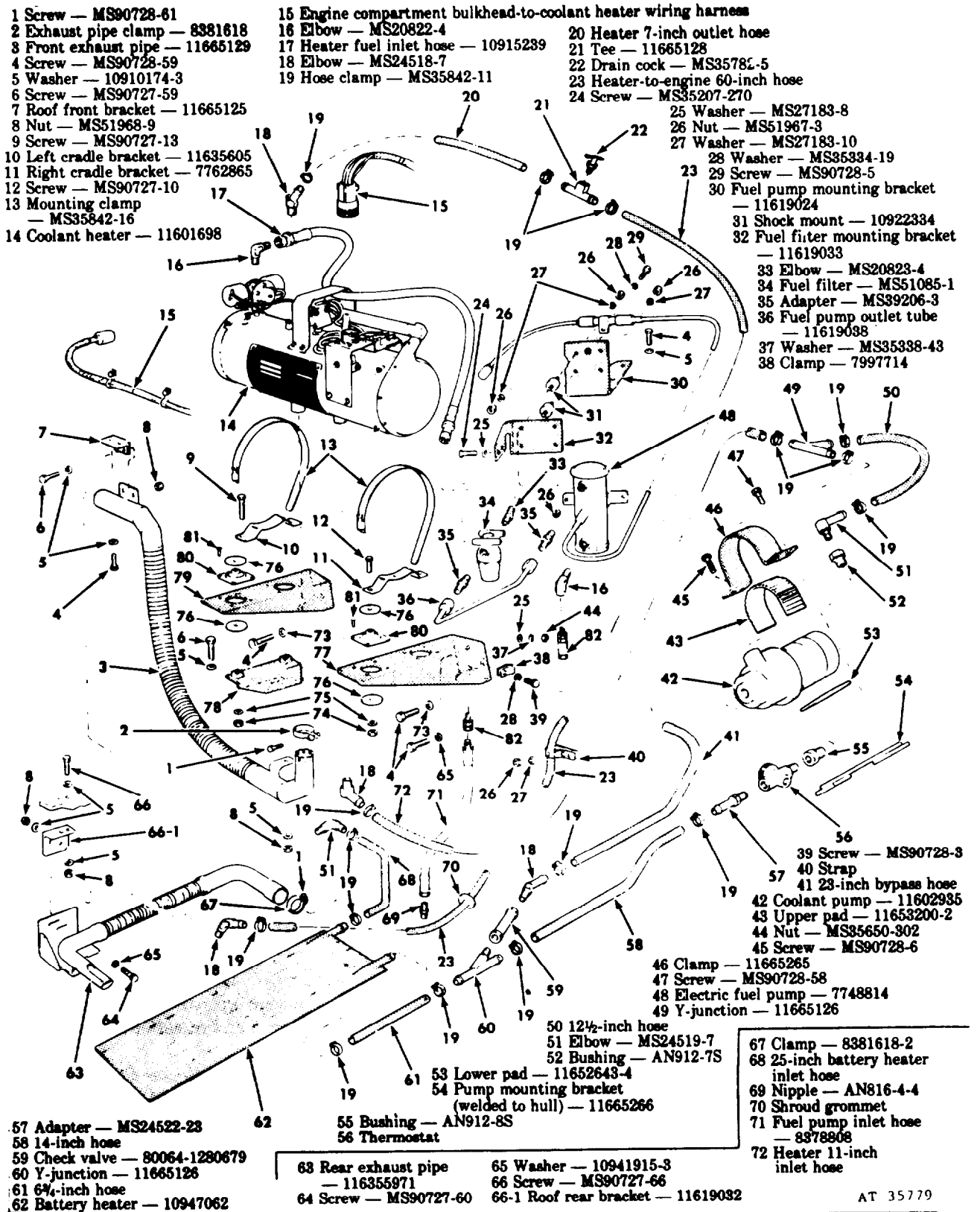

Figure 3-152. Winterization kit 11678893 — exploded view.

Figure 3-152. Winterization hit 11678893 - exploded view.

(2) Install fuel filter on mounting bracket (32) using two screws (24) two washers (37), four washers (25) and two nuts (44).

(3) Install coolant heater fuel inlet hose (17) on fuel outlet port elbow.

(4) install elbow (33) in inlet (lower) port and adapter (35) in outlet (upper) port of electric fuel pump (43).

(5) Install four shock mounts (31) on fuel pump mounting bracket (30) using four washers (27) and four nuts (26).

(6) Install assembled fuel filter and mounting bracket on shock mounts and fuel pump on upper two shock mount studs extending through fuel filter mounting bracket. Secure assembly using two washers (27) (on lower studs) and four nuts (26). (Do not use washers when installing fuel pump on upper studs.)

(7) Install fuel pump outlet tube (36) on adapters in fuel pump and fuel filter and tighten fittings.

(8) Install assembled pump and filter assembly on tapping blocks on center fuel tank (fig. 3-140) using three washers (5) and three screws (4).

*d. Assembly and Installation of Coolant Pump and Mounting Bracket (figs. 3-152 and 3-156).*

(1) Install bushing (52) and elbow (18) in outlet port of coolant pump (42).

(2) Install bushing (55), thermostat (56), and adapter (57) in inlet port of coolant pump (42).

(3) Position coolant pump mounting bracket (54) in relation to shroud mounting plate and weld in position.

(4) Install assembled coolant pump on bracket (54), position pads (43) and (53), and secure pump and clamp (46) with three screws (47). Use screw (45) and washer (28) to secure pump ground cable to bracket.

*e. Assembly and Installation of Coolant Heater (fig. 3-152 and 3-154).*

(1) Install elbow (16) in top of heater (14) fuel control valve.

(2) Install two elbows (18); one in inlet port (bottom) and one in outlet port (top) of coolant heater (14). Flame detector switch guard must be removed to install elbow in top outlet port.

(3) Preassemble coolant heater 11-inch inlet hose, check valve 23-inch outlet hose, coolant pump 121/2 inch outlet hose, and metal Y-junction (49) using three clamps (19). Place another clamp (19) over free end of coolant heater 11-inch inlet hose, place hose over heater inlet elbow on bottom of heater, and secure clamp.

(4) Position heater two mounting clamps (13) through openings in heater cradle brackets. Place coolant heater (14) on mounting brackets, routing attached coolant inlet hose under heater right mounting bracket and in front of fuel pump, towards coolant pump outlet fitting.

(5) Position heater to align exhaust outlet with exhaust pipe (3) (installed in *b* above) and insert outlet into pipe. Secure heater mounting clamps but do not completely tighten.

(6) Tighten screw (6) to secure exhaust pipe (3) to bracket (79) (installed in *b* above).

(7) Securely tighten two clamps (13) to retain heater in mounting brackets.

(8) Position and tighten screw in exhaust pipe clamp 8381618 (*b*(6) above) to secure exhaust pipe to heater.

(9) Pass free end of fuel hose (17,c(3)above) under flame detector switch guard and then connect hose to elbow on coolant heater fuel control valve and tighten fittings on heater and fuel filter.

(10) Place one clamp (19) over free end of coolant pump 121/2inch outlet hose ((3) above). Route hose in front of fuel pump bracket on top of fuel tank, connect hose to coolant pump outlet elbow (18), and tighten clamp.

*f. Installation of Fuel Hoses (figs. 3-144 and 3-152).*

(1) Remove plug MS49005-4 for fuel shutoff valve 8678328 at bottom of center fuel tank and install nipple (69).

(2) Install one end of fuel pump inlet hose (71) at fuel shutoff valve nipple and other end at inlet elbow of fuel pump (48).

(3) Coolant heater fuel inlet hose (17) connecting coolant heater and fuel filter was previously installed. Refer to *c*(3) and *e*(8).

(4) Open fuel shutoff valve at bottom of center fuel tank.

*g. Installation of Battery Heater (figs. 3-145 and 3-152).*

(1) Remove blank grommet from battery insulation at front of battery compartment.

(2) Place battery heater (62) through battery access door with flat side up. During replacement of heater, guide inlet tube through hole in insulation (blank grommet location) and final position heater on battery tray.

(3) Remove four screws and remove cover 10952459 from battery compartment vent tube inlet. Turn cover 180 degrees and reinstall to seal vent tube inlet.

*h Installation of Coolant Heater Control Box (figs. 3-246 and 3-147).* Attach coolant heater control box 10885798 to bracket on hull upper left plate in driver's compartment, opposite personnel heater control box, using two washers MS35334-19 and two nuts MS51967-3.

*i Installation of Coolant Heater Control Bar-To-Engine Compartment Bulkhead Wiring Harness (figs. 3-146 and 3-155).*

(1) Remove screws, washers, and nuts, and remove access cover 10949097 and gasket from engine com-

partment bulkhead. Discard cover.

(2) Install harness 10953275 with receptacle on engine compartment bulkhead using gasket, and attaching screws, washers, and nuts.

(3) At other end of harness, insert plug into heater control box 10885798 and tighten.

(4) To support harness 10953275 from control box to bulkhead, remove screws from eight straps retaining adjacent harness. Position harness 10953275 with adjacent harness and reinstall screws and straps. Use new lengths of strap material 8724501 as required.

(5) Remove dummy connector from hull front power harness and lead No. 561 and connect lead to heater control box head.

*j. Installation of Engine Compartment Bulkhead-To-Coolant Heater Wiring Harness figs. 3-146 and 3-155).*

(1) Insert harness 11619039 plug into bulkhead receptacle of harness 10953275 (*i* above).

(2) Remove screws from three straps retaining existing harness and fire extinguisher tube to center fuel tank. Place heater harness 11619039 in position with existing harness and reinstall straps. Use new lengths of strap material 8724501 as required.

(3) Install harness plug in coolant heater receptacle.

(4) Install harness plug (two circuit No. 563) in coolant thermostat.

(5) Install harness lead (circuit No, 565) to coolant pump lead.

(6) Install harness lead (circuit No. 563A) to fuel pump lead.

(7) Select one ground lead of harness and ground lead from fuel pump suppressor bracket and attach both ground leads to fuel pump mounting bracket 11619024 using screw MS90728-5 and washer MS35334-19.

(8) Position clamp 7997714 on harness and install both clamp and remaining ground lead to mounting pad on heater right mounting bracket using screw MS90728-3 and washer MS35334-19.

*k. Installation of Coolant Hoses (figs. 3-152 and 3-156).*

(1) Preassemble metal Y-junction (60), check valve (59), and elbow (18).

(2) Place one clamp (19) at each end of battery heater 63/4inch outlet hose and one clamp at each end of coolant pump 14-inch inlet hose. Install hoses on metal Y-junction and tighten clamps. Install free end of 63/4inch hose at battery heater outlet and free end of 14-inch hose at coolant pump thermostat and tighten clamps.

(3) Remove plug MS49005-8 from engine crossover tube at right cylinder bank location and install elbow (51) in its place.

(4) Remove plug MS20913-45 from engine-to-

radiator tube and install elbow (18) in its place.

(5) Place one clamp (19) over one end of 60-inch coolant hose. Position this end of hose on engine-to-radiator tube elbow and tighten clamp.

(6) Remove solid grommet 10952908 from cooling fan lower right shroud and replace with grommet MS35489-52.

(7) Install right fuel tank (fig. 2-8).

(8) Install power plant (TM g-2350-230-20-1).

(9) Place one clamp (19) at each end of 25-inch coolant hose. Position one end on engine crossover tube elbow and other end on battery heater and tighten clamps.

(10) Preassemble tee (21) and drain cock (22). Place one clamp (19) at each end of coolant heater 7-inch outlet hose. Connect one end of hose to tee and tighten clamp. Connect free end of hose to coolant heater outlet elbow at top of heater. Position tee and drain cock in vertical position and tighten clamp on heater outlet elbow.

(11) Insert free end of 60-inch coolant hose ((5) above) through grommet in shroud ((6) above). Route hose around turret ring right support post and upward to tee at coolant heater 1-inch outlet hose ((10) above). Place clamp on hose, install hose on tee, and tighten clamp.

#### *1. Filling and Bleeding Procedure.*

(1) Before refilling engine and heater coolant system, open drain cock (22) in coolant heater outlet hose at top of heater.

(2) Fill engine and heater coolant system until coolant spills from drain cock and then close drain cock.

(3) Complete filling coolant system to full level as indicated on surge tank.

#### **NOTE**

After refilling engine and heater coolant system to full level in accordance with vehicle arctic preparation procedures, an air bleed must be performed on kit and engine coolant system to avoid coolant heater malfunction and possible failure. Air bleed should also be performed after reinstallation of coolant heater or coolant lines removed from coolant system. The coolant pump can be operated to aid air bleed procedure by electrically connecting pump to vehicle-installed batteries with jumper wire.

#### **CAUTION**

Connect battery positive terminal to lead labeled 565 on coolant pump.

*m. Checkout and Operating Instructions.* Refer to paragraph 3-460.

*n. Installation of Grilles and Grille Cover.* Refer to paragraph 3-46n and figure 3-149.

*o. Repositioning Crew Compartment Personnel*

Heater (fig. 3-158).

(1) Remove and discard personnel heater existing exhaust pipe 11605224. Retain clamp 8381618, clamp 8381618-1, and two screws MS90728-61 for reinstallation.

(2) Remove four screws MS51957-42, which attach plenum to heater, and retain screws for reinstallation. Separate plenum from heater.

(3) Remove and discard fuel filter-to-heater fuel hose 10915239-4.

(4) Disconnect wiring harness.

(5) Loosen heater two mounting clamps MS35842-16.

(6) Rotate heater 180° and tighten mounting clamps to 25 to 35 lb-ft.

(7) Position plenum on heater and install four

screws MS51957-42.

(8) Install new fuel filter-to-heater fuel hose 10915239-3.

(9) Position clamp 8381618 with screw MS90728-61 at elbow end of new exhaust pipe, install on heater exhaust outlet, and tighten clamp. Position clamp 8381618-1 with screw MS90728-61 at adapter end of new exhaust pipe, install on adapter, and tighten clamp.

(10) Install insulation 11694957 on bottom of exhaust pipe at adapter end and secure by wrapping entire length of exhaust pipe between clamps with asbestos tape MIL-T-4117. Secure tape with wire MS20995-C41-8 at three places.

(11) Connect wiring harness.

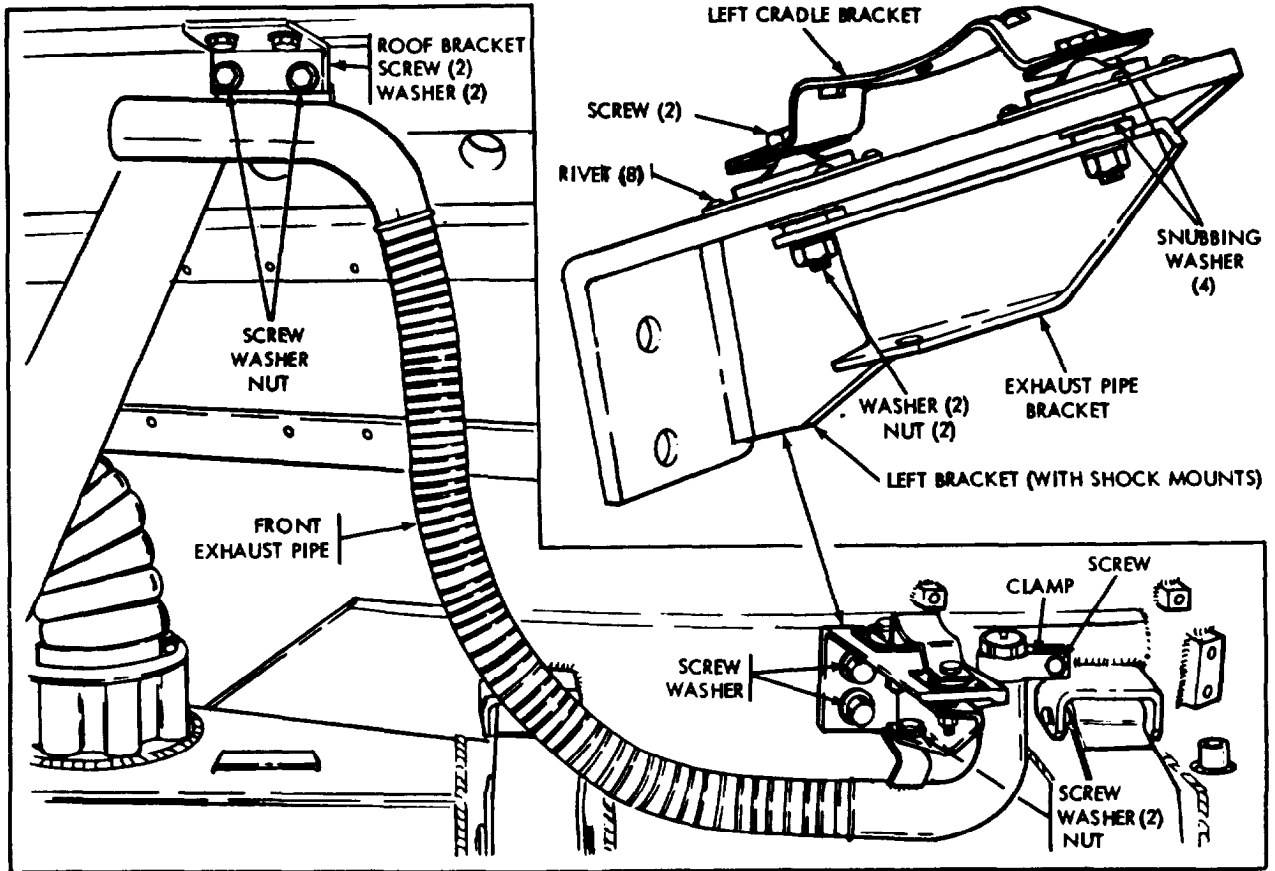

A. ASSEMBLE AND INSTALL COOLANT HEATER LEFT CRADLE BRACKET, LEFT BRACKET, AND FRONT EXHAUST PIPE.

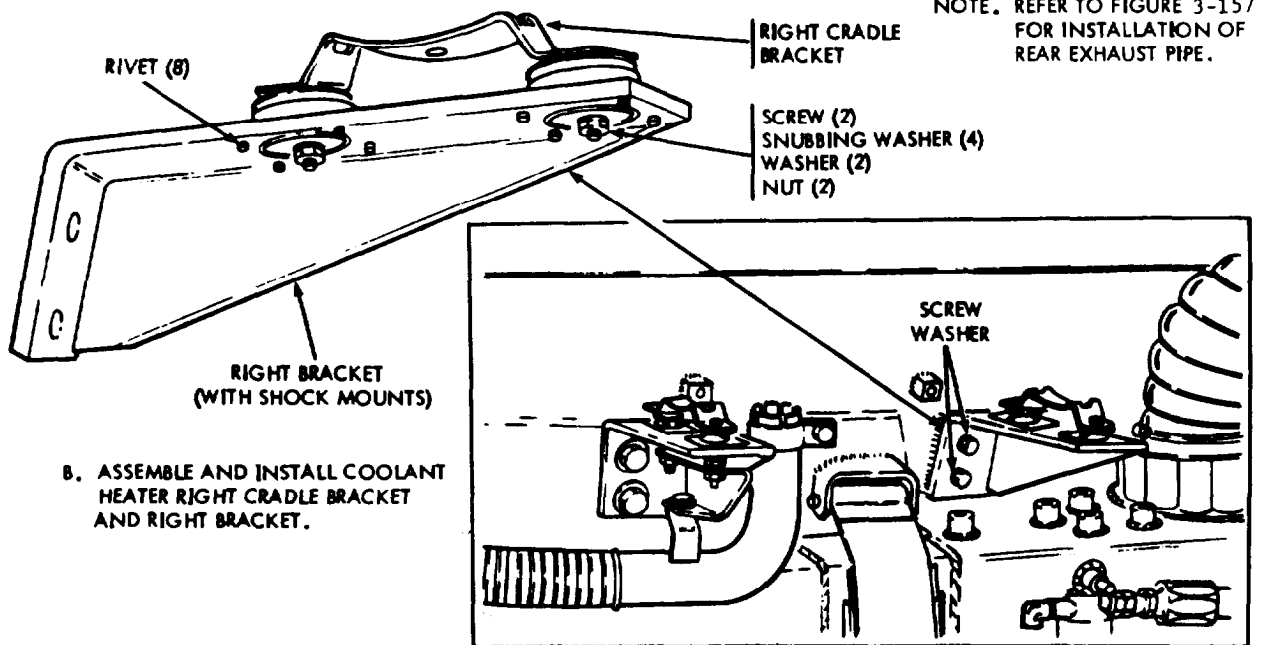

B. ASSEMBLE AND INSTALL COOLANT HEATER RIGHT CRADLE BRACKET AND RIGHT BRACKET.

TA 01483

Figure 3-153. Installation of winterization kit - 11678893 coolant heater brackets and front exhaust pipe

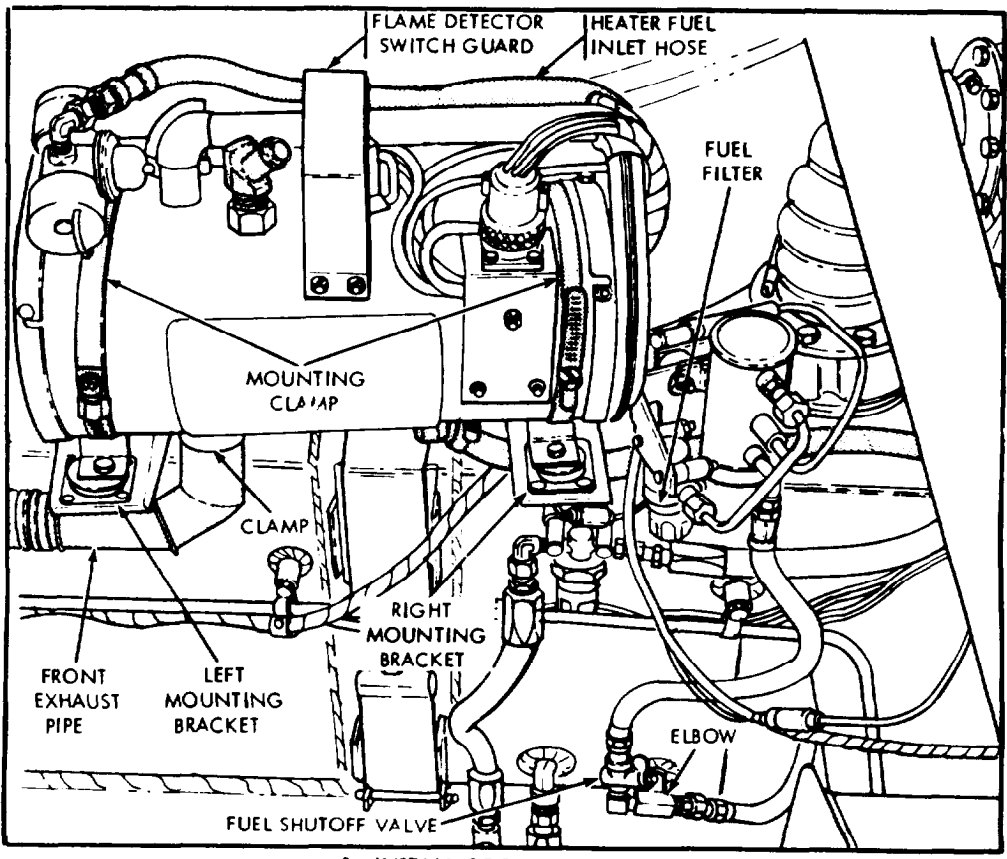
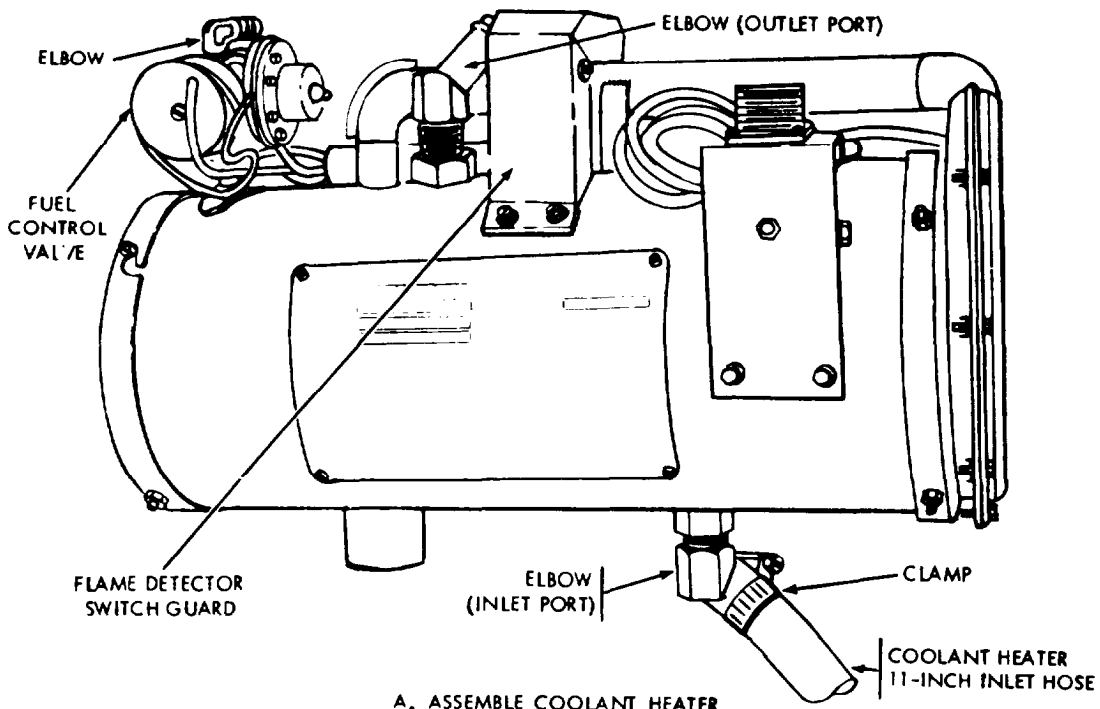

AT 35781

Figure 3-154. Installation of winterization kit- 11678893 coolant heater.

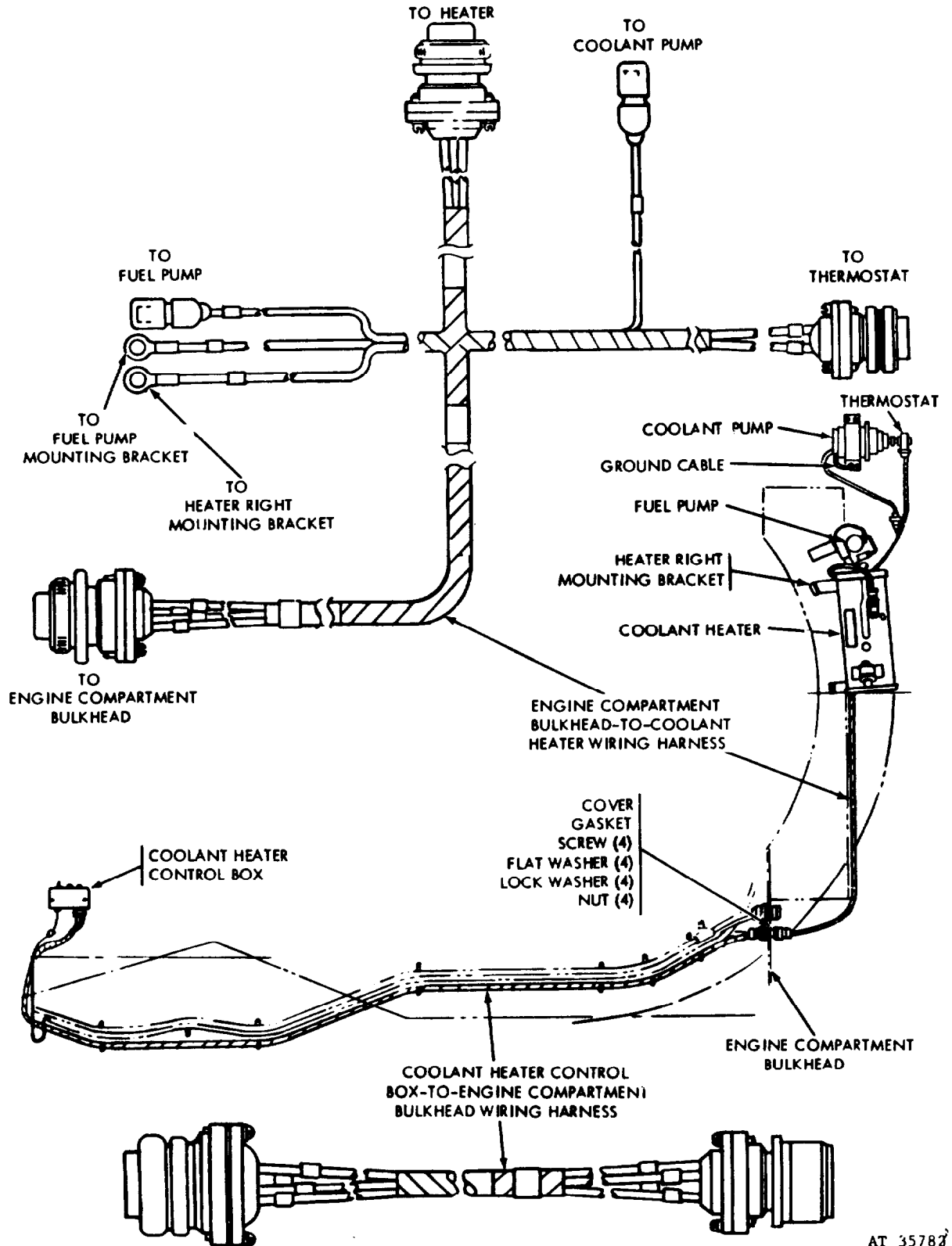

Figure 3-155. Installation of winterization kit- 11678893 wiring harness



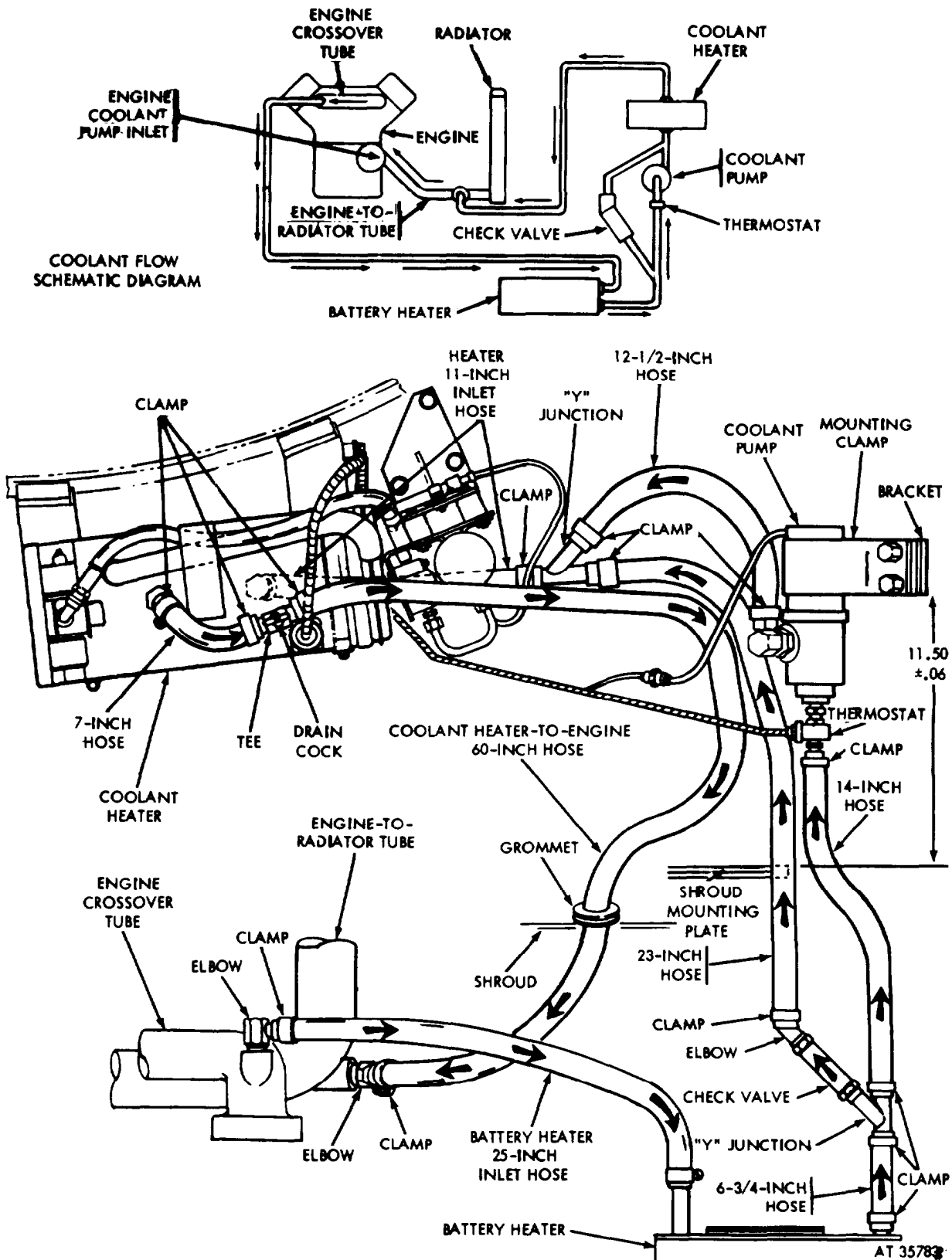
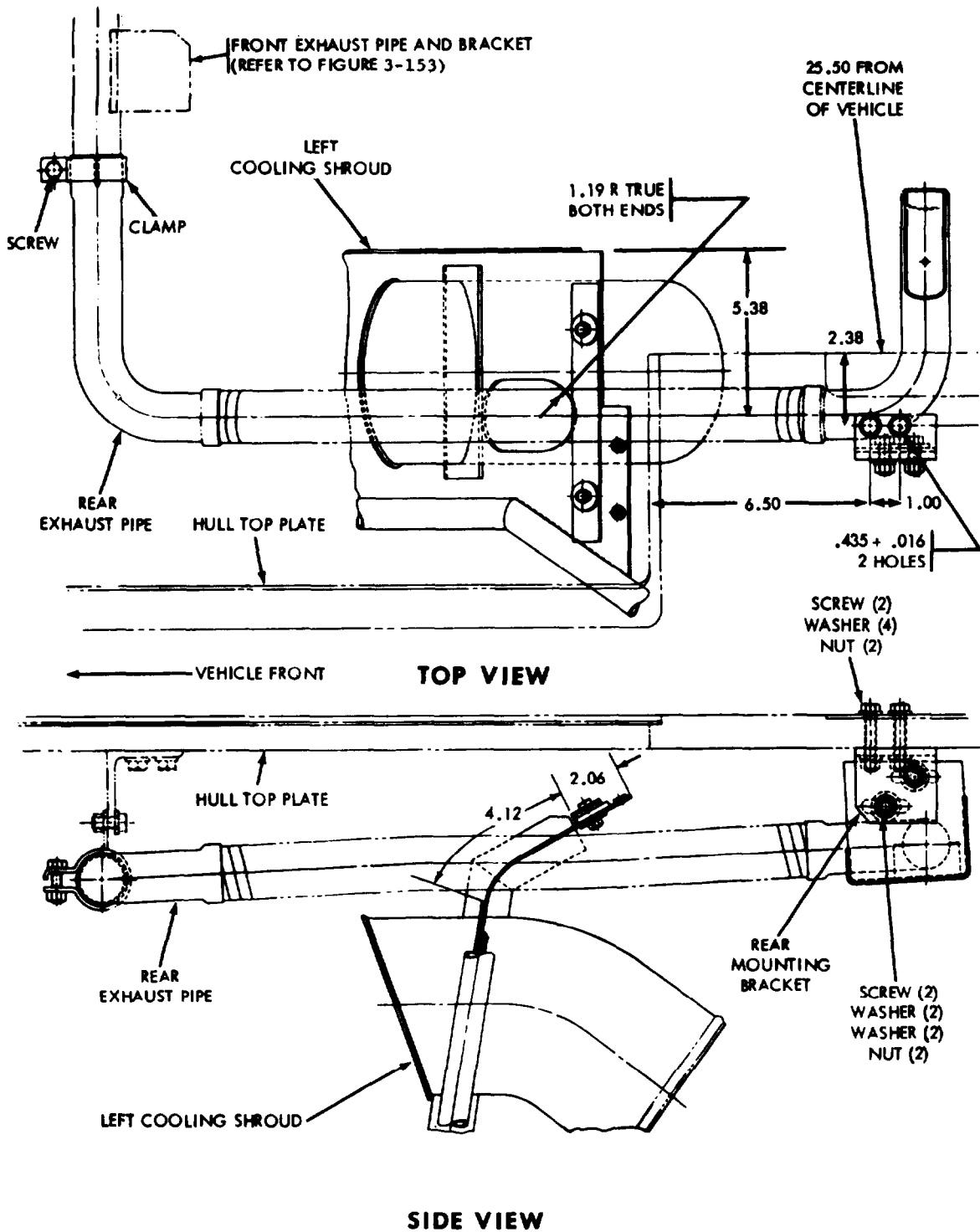
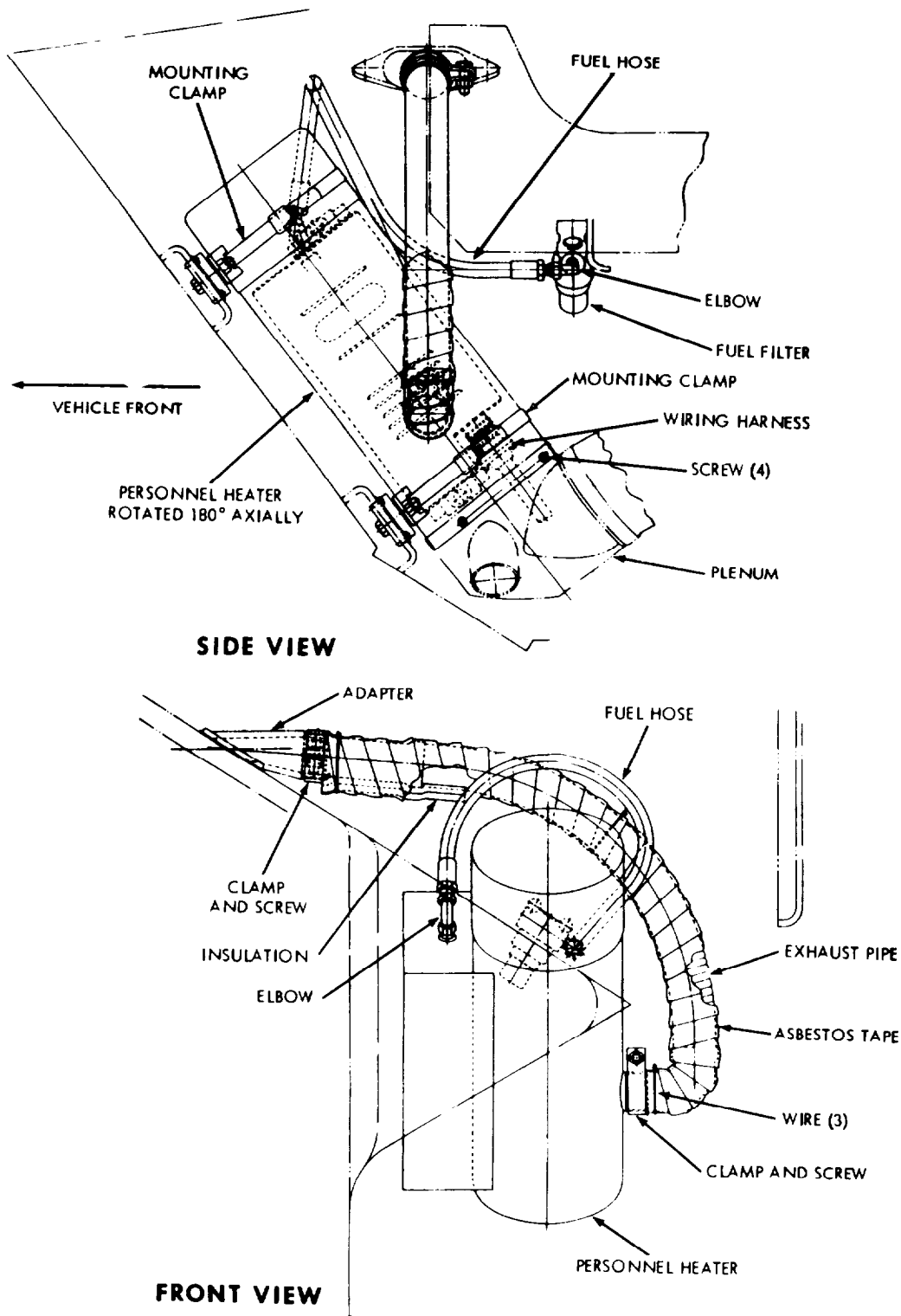

Figure 3-156. Installation of winterization kit- 11678893 coolant hoses -top view.



TA 014837

Figure 3-157. Installation of winterization hit- 1678893 rear exhaust pipe.



AT 35785

Figure 3-158. Installation of winterization kit - 11678893 crew compartment personnel heater fuel hose and exhaust pipe.

## CHAPTER 4

### FINAL INSPECTION

#### 4-1. General

This chapter provides the vehicle inspector with information and guidance to complete a vehicle inspection against maintenance detailed in this manual for the hull and suspension portion of the AR/AAV M551, M551A1.

#### 4-2. Personnel

The following personnel are required for vehicle evaluation and test purposes:

- a. Qualified direct support inspector.
- b. Automotive mechanic.
- c. Driver to move and operate vehicle.

#### 4-3. Equipment

The following equipment is required:

- a. Tools and TMDE normally found in shop sets and general mechanics' tool boxes.
- b. Depth gage.
- c. Steel straight edge, 36 inches.
- d. Flashlight.
- e. Shop bay, with grease pit.

#### 4-4. Preparation

The vehicle will be prepared for inspection as follows:

- a. Vehicle will be washed and as free as possible of dirt, grease, and oil; both interior and exterior.
- b. Position vehicle over a grease pit.
- c. Open access doors, hatches, and covers.
- d. After completion of the stationary portion of the inspection, the vehicle will be made ready for road test.

#### 4-5. Items to Inspect

The following items will be inspected.

a. Paint. Visually examine the exterior and interior painted surfaces. Look for areas where paint is peeling, weathered, oxidized, or missing requiring touch-up painting. Overall paint in good condition is required.

b. Hull Exterior, Interior, and Suspension These items are given a visual and functional inspection as follows:

(1) Hull is inspected for obvious signs of distortion and warpage. Check for gouges and cracks.

(2) Suspension components are inspected for obvious misalignment with the hull which will cause abnormal wear, cracks, and warpage.

(3) All exterior and interior access covers, doors, and hatches will be functionally inspected for proper alignment, sealing, latching, and locking.

(4) Hull bottom plates will be inspected using a depth gage and 36-inch straight edge. Inspection is done from a grease pit. Clean the areas to be inspected. Check for cracks, sags, dents, and distortion. Sags, cracks, dents, or distortion in excess of  $\frac{1}{8}$ -inch deep by 36 inches long are to be repaired.

c. Hull Front and Rear Plates. These items will be inspected visually for warpage, cracks, distortion, and abnormal wear. Cracks around mounting brackets will be repaired.

d. Access Covers, Doors and Hatches, Air Cleaner, and Battery Doors. Inspect for proper sealing, locking, and fit to hull. Check for breaks, cracks, and abnormal wear around mounts. This is a visual and functional inspection. Repair any item which shows abnormal wear, cracks or breaks.

e. Engine Access Covers and Grilles. Inspect for proper alignment to the hull. Check for cracks, breaks, warpage, sealing, and locking.

f. Hull Towing Lugs, Brackets, Hangers, and Guards. These items to be visually checked for being broken or missing. Repair or replace as needed.

g. Surfboard and Barriers - Flotation Components Inspect for dents, bends, gouges, punctures, and holes. Punctures and holes will be repaired.

h. Roadwheel Arm Housing. Inspect for excessive wear, physical damage, excessive looseness, and lubricant leakage. Housing movement relative to hull will be repaired.

i. Torsion Bar Anchors. Inspect for abnormal wear, cracks, or other physical damage. Anchor movement relative to hull will be repaired.

j. Idler Wheel Hub Mount. Inspect for abnormal wear, cracks, or other physical wear. Movement relative to hull will be repaired.

k. Track Adjuster Mount. Inspect for abnormal wear, cracks, or other physical damage. Mount movement relative to hull is to be repaired.

l. Sprocket Hub Mount Inspect for abnormal wear, cracks, or other physical damage. Movement relative to hull will be repaired.

m. Shock Absorber Mount. Inspect for abnormal wear, cracks, or other physical damage. Movement relative to hull will be repaired.

n. Transmission Trunnion Mounts. Inspect for distortion, cracks, breaks or other physical damage. Cracked, sprung, or broken mounts to be replaced.

o. Fuel Tanks. Inspect for excessive dents, corrosion, or other physical damage. Check for fuel leakage. All leaks to be repaired or fuel tanks replaced.

p. Hull Electrical System. Visually and physically inspect the cables and connectors on the hull front power wiring harness. Check for discolored wires indicating overheating on three or more inches of any wire. Check for cracked or broken insulation on two or more wires in any bundle. Check for corrosion, broken or missing pins in connectors. Check for insulation soaked in oil or hydraulic fluid. If the insulation comes

off the wires when rolled between the thumb and index finger, it is saturated and deteriorated. Inspect for electrical shorts by means of a continuity check of the system. All conditions above require replacement of harness.

q. *Harness, Driver's Indicator Panel.* This panel harness includes the panel assembly instruments, panel assembly master switch, and panel assembly warning lights. Inspect for wires having cracked or deteriorated insulation. Check for wires having three or more inches of discoloration indicating an overheating condition. Inspect connectors for being corroded, bent, broken or missing. Inspect for electrical shorts by means of a continuity check of the harness. All conditions above require replacement of harness.

r. *Harness, Hull Front Power.* Inspect cables and connectors for resistance; insulation for deterioration or cracking; pins in connectors for being corroded, missing, bent, or broken; protective covering for being unwound. Inspection will be visual with limited disassembly to permit continuity checks of the harness. All conditions above require replacement of harness.

s. *Accelerator and Hand Throttle Control Assembly.* Inspect for binding and physical damage. Repair or replace as required.

t. *Engine.* The engine will be checked using a three-step method as follows:

(1) *Engine starting at above 40°F.* Check that battery, starter, and fuel system are in good order. Check for slow cranking speed and difficult or no start.

(2) Check engine noise for knock, piston slap, and abnormal sounds.

(3) Make stall test of engine/drive train at 2,100 to 2,400 rpm. If engine stall speed is below 2,100 rpm, engine is not delivering full power and reference is made to TM 9-2815-205-34 for correction.

**CAUTION**

Do not exceed 15 second limit on stall test. Observe transmission temperature warning light.

u. *Transmission* The transmission will be checked using a three-step method as follows:

(1) Check shifting for abnormal action.

(2) Check transmission oil (fluid) for discoloration, cloudy, bad odor.

(3) Make stall test for abnormal condition. If engine stall speed is substantially above 2,400 rpm, clutch slippage is present in transmission and reference is made to TM 9-2520-249-34 for correction.

**CAUTION**

Do not exceed 15 second limit on stall test. Observe transmission temperature warning light.

**APPENDIX A  
REFERENCES**

**Publications**

DA Form 2028..... Recommended Changes to Publications and Blank Forms

DA Form 2407..... Maintenance Bequest

DA Form 2408..... Equipment Log Assembly

DA Form 2409..... Equipment Maintenance Leg

TM9-207..... Operation and Maintenance of Ordnance Materiel in Cold Weather 0°F. to -65°F.

TM 9-214 ..... Inspection, Care and Maintenance of Antifriction Bearings

TM 9-237 ..... Operator's Manual: Welding Theory and Application

TM 9-247 ..... Materials Used for Cleaning, Preserving, Abrading, and Cementing Ordnance Material; and Belated Materials Including Chemicals

TM 38-230-1 ..... Packaging of Materiel: Preservation (Volume I)

TM 38-230-2 ..... Preservation, Packaging, and Packing of Military Supplies and Equipment: Packing (Volume II)

TM 38.750..... The Army Maintenance Management Systems (TAMMS)

TM 38-750-1..... The Army Maintenance Management System (TAMMS) Field Command procedures

IA 9-2350-230-12..... Armored Reconnaissance/Airborne Assault Vehicle: Full Tracked, 152MM, M551

TM 9-2350-230-20-1..... Organizational Maintenance Manual, Hull, Suspension, and Miscellaneous Components of the Hull for Armored Reconnaissance/Airborne Assault Vehicle: Full Tracked, 152MM Gun/Launcher M551 and M551A1

TM 9-2350-230-24P/1 ..... Organizational, Direct and General Support Maintenance Repair Parts and Special Tools Lists (Including Depot Maintenance Allowances) for Hull, Suspension and Miscellaneous Components for Armored Reconnaissance/Airborne Assault Vehicle: Full Tracked, 152MM, M551, and M551A1

TM 9-2520-249-34..... Direct Support and General Support Maintenance Manual and Repair Parts and Special Tools List (Including Depot Maintenance Allowances) Transmission W/Container XTG 250-1A

TM 9-2815-205-34 ..... Direct Support and General Support Maintenance Manual, Engine Diesel, 6V53 and 6V53T

TM 9-2815-205-34P..... Direct Support and General Support Maintenance Manual for Engine, Diesel 6V53 and 6V53T, and Container Assembly

TM 9-2920-224-35..... Direct Support and General Support Maintenance Manual for Generator, Engine Assembly (300 amp)

TM 750-245-4..... Direct Support and General Support Quality Control Inspector's Inspection Criteria



## APPENDIX B EXPENDABLE AND DURABLE ITEMS LIST

### B-1. General

This appendix lists expendable and durable items you will need to maintain the M551A1/M551NTC Sheridan hull. This listing is for informational

purposes only and is not authority to requisition the listed items. These items are authorized to you by CTA 50-970, Expendable Items (except Medical, Class V, Repair Parts, and Heraldic Items).

### Section I. INTRODUCTION

#### B-2. Explanation of Columns

*a. Column (1), Item No.* This number is assigned to the entry in the listing for referencing when required.

*b. Column (2), Level.* This column identifies the lowest level of maintenance that requires the listed item.

C-Operator/Crew  
O-Unit Maintenance  
F-Direct Support Maintenance  
H-General Support Maintenance

*c. Column (3), National Stock Number (NSN).* This is the national stock number assigned to the item; use it to request or requisition the item.

*d. Column (4), Description.* Indicates the Federal item name and, if required, a description to identify the item. The last line for each item indicates the

Commercial and Government Entity Code (CAGEC) in parentheses followed by the part number.

*e. Column (5), Unit of Measure (U/M)/ Unit of Issue (U/I).* This measure is expressed by a two-character alphabetical abbreviation (e.g. EA, IN, PR). If the unit of measure differs from the unit of issue as shown in the Army Master Data File (AMDF), requisition the lowest unit of issue that will satisfy your requirements.

Abbreviation	Unit
CC	Cubic centimeter
EA	Each
FT	Foot
GL	Gallon
KT	Kit
LB	Pound
OZ	Ounce
PT	Pint
QT	Quart

### Section II. EXPENDABLE AND DURABLE ITEMS LIST

#### B-3. Expendable and Durable Items List

(1) Item No.	(2) Level	(3) NSN	(4) Description	(5) (U/M)/ (U/I)
1	F	8040-00-582-4596	Adhesive, resilient deck covering, 1-gal can: (81349) MIL-A-21016	GL
2	F	8040-00-738-6429	Adhesive and sealing compound, epoxy, metal filled, 11-oz tube kit: (81348) MMM-A-1754	OZ
3	F	6850-00-181-7929	Antifreeze, ethylene glycol, inhibited, heavy duty, single package, 1-gal bottle: (81349) MILA-46153	GL
4	F	8030-00-290-5141	Coating compound, bituminous solvent type (for ammunition), black, 1-gal can: (81349) MIL-C-450	GL
5		6850-00-142-8840	Cleaner, 12 oz can: (81349) MIL-I-25135	CN
6	F	6850-00-145-0255	Developer, kit: (81349) MIL-I-25135	KT
7	F	6850-01-331-3349	Dry-cleaning and degreasing solvent, 5-gal can: (81348) P-D-680	GL
	F	6850-00-145-0255	Dye penetrant, kit: (81349) MIL-I-25135	KT



**B-3. Expendable and Durable Items List-Continued**

(1) Item No.	(2) Level	(3) NSN	(4) Description	(5) (U/M)/ (U/I)
9	F	9150-01-197-7689	Grease, automotive and artillery, 6.5-lb can: (81349) MIL-G-10924	LB
10	F	9150-01-197-7693	Grease, automotive and artillery, 14-oz cartridge: (81349) MIL-G-10924	OZ
11	F	9150-00-944-8953	Grease, aircraft, general purpose, wide temperature range, 1-lb can: (81349) MIL-G-81322	LB
12	F	6850-00-826-0981	Inspection materials, penetrants, kit: (81349) MIL-I-25135	KT
13	F	9150-00-189-6727	Lubricating oil, (OEIO), internal combustion engine, combat/tactical service, 1-qt can: (81349) MIL-L-2104	QT
14	F	3439-00-063-5200	Metal filler, type 5356, 50 lb : (81348) QQ-R-566	LB
15	F	9330-00-488-2059	Plastic foam insulation, thermal (polyurethane), each: (81349) MIL-P-43110	EA
16	F	8010-01-309-0328	Primer, epoxy coating, corrosion inhibiting, lead and chromate free, kit: (81349) MIL-P-53022	KT
17	F	8010-01-193-0519	Primer coating, epoxy water reducible, lead and chromate free, kit: (81349) MIL-P-53030	KT
18	F	8030-00-656-1426	Sealing compound, 1-pt can: (62377) PERMA-EX-3D	PT
19	F	8030-00-081-2339	Sealing compound, grade E, 2-cu cm tube: (81349) MIL-L-2104	CC
20	F	8030-00-252-3391	Sealing compound, type II, gasket, hydrocarbon fluid and water resistant, 11-oz tube: (81349) MIL-S-45180	OZ
21	F	8030-00-999-3895	Sealing compound, type II	
22	F	8030-00-081-2328	Sealing, locking and retaining compounds (single component), 50-cu cm bottle: (80244) MIL-S-22473	CC
23	F	5330-00-618-4618	Tape, asbestos, 100-ft roll: (81349) MIL-T-4117	FT
24	F	8010-01-168-0684	Thinner, type II, aircraft coating, 55-gal drum: (81349) MIL-T-81772	GL
25	F	8010-00-181-8080	Thinner, type I, aircraft coating, 1-gal drum: (81349) MIL-T-81772	GL
26	F		Wire: M20995-C41-8	

**INDEX**

	Page
<b>A</b>	
Adjuster, track hydraulic .....	3-100
Aluminum welding .....	2-5
Arm:	
Idler .....	3-106
Roadwheel .....	3-102
Authorized forms .....	1-1
<b>B</b>	
Barrier, flotation .....	3-110
Bilge pump .....	3-134
Blower:	
Coolant heater .....	3-194
Personnel heater .....	3-151
<b>C</b>	
Cap, transmission trunion support 3-10	
Charging, fire extinguishers .....	3-167
Circuit numbers, electrical .....	3-53
Cleaning .....	2-4
Clutch, fan drive .....	3-22
Combustion air blower:	
Personnel heater .....	3-151
Winterization kit heater .....	3-194
Common tools .....	1-3
Cone, engine crankshaft pulley .....	3-7
Crankshaft pulley, engine .....	3-7
Cylinder.. .....	3-169
<b>D</b>	
Drive, generator .....	3-61
Drive sprocket .....	3-108
Driver's:	
Indicator panel .....	3-61
Rotatable hatch .....	3-111
<b>E</b>	
Electrical system:	
Engine .....	3-53
Hull .....	3-61
Engine:	
Electrical system .....	3-53
Mounts.. .....	3-6.1
Separation from transmission .....	3-2
Exchanger, heat:	
Personnel heater .....	3-147
Winterization kit heater.. .....	3-191
Expendable and durable items list .....	B-1
<b>F</b>	
Fan clutch:	
Bearing retainer .....	3-15
Disassembly/Assembly .....	3-27
Fire extinguisher recharging:	
Crew compartment .....	3-173
Engine compartment .....	3-167
Flotation:	
Barrier and surfboard .....	3-110
Fuel tanks:	
Removal and installation .....	2-16
Repair .....	3-12
Fuse, fuel tank transmitter .....	3-60

	<b>G</b>	Page
Generator:		
Drive .....		3-61
	<b>H</b>	
Harness, wiring:		
Engine .....		3-53
Hull .....		3-61
Hatch, rotatable, driver's .....		3-110
Heater:		
Personnel .....		3-139
Winterization kit .....		3-175
Hood, driver's .....		3-110
Housing		
Roadwheel arm support .....		3-98
Hub:		
Idle wheel .....		3-99
Sprocket .....		3-108
Hydraulic adjuster, track .....		3-100
	<b>I</b>	
Idle wheel and hub .....		3-99
Improvised tools .....		1-3
Installation references .....		1-2, 1-3
	<b>K</b>	
Kit:		
Fuel tank .....		3-12
Mine protective .....		3-129
Radiator repair .....		3-17
Track hydraulic adjuster .....		3-100
Winterization .....		3-175
	<b>L</b>	
Lock, parking brake .....		3-129
Lubrication .....		2-1
	<b>M</b>	
Maintenance, general .....		2-4
MIG process welding .....		2-11
Mine protective kit .....		3-129
	<b>O</b>	
Overheat switch:		
Personnel heater .....		3-144
Winterization kit heater .....		3-193
	<b>P</b>	
Painting .....		2-4
Panel, indicator, driver's .....		3-61
Parking brake lock .....		3-129
Personnel heater:		
Disassembly/Assembly .....		3-139
Repair data .....	3-148,	3-149
Wiring harness .....		3-71
Plate, mine protective kit .....		3-130
Powerplant:		
Separation/Assembly .....		3-2
stall test .....		3-6
Test stand .....		1-4
pulley, crankshaft .....		3-7
Pump:		
Bilge .....		3-134
Coolant, winterization kit .....		3-172
Fuel, winterization kit .....		3-178

<b>R</b>	<b>Page</b>
Radiator repair .....	3-16
Recharging, fire extinguisher .....	3-167
Regulator, generator .....	3-82
Repair data:	
Bilge pump .....	3-138
Driver's hatch .....	3-110
Fan clutch .....	3-22
Generator drive .....	3-75, 3-76
Personnel heater .....	3-151
Roadwheel arm .....	3-103
Track drive sprocket .....	3-109
Track hydraulic adjuster .....	3-101
Repair procedure:	
Barrier .....	3-125
Fuel tanks .....	3-12
Radiator .....	3-17
Skin, flotation .....	3-125
Retainer, fan clutch shaft bearing .....	3-33
Roadwheel arm .....	3-102

<b>S</b>	<b>Page</b>
Security shields, hull .....	2-18
Shock absorber bearings .....	3-110
Skin, flotation .....	3-125
Special tools .....	1-4
Specific repair data .....	2-14
Stall test, engine .....	3-6
Stand, improvised, powerplant .....	1-4
Stop-hole drilling .....	2-10
Surfboard:	
Disassembly/Assembly .....	3-115

<b>T</b>	<b>Page</b>
Tables:	
Flotation barrier repair .....	3-125
Fuel tank welding data .....	2-9
Hull electrical circuit No's .....	3-53, 3-54
Special tools and equipment .....	1-3, 1-4
Specific repair data .....	2-14
Troubleshooting .....	2-1, 2-4
Tank, fuel:	
Removal/Installation .....	2-16
Repair .....	3-12
TIG process welding .....	2-12
Tools:	
Improvised .....	1-3
Special .....	1-3, 1-4
Transmission oil cooler repair .....	3-16, 3-17
Transmission separation from engine .....	3-2

<b>V</b>	<b>Page</b>
Valve:	
Fire extinguisher .....	3-173
Fuel, personnel heater .....	3-145
Winterization heater .....	3-193
Voltage regulator .....	3-82

<b>W</b>	<b>Page</b>
Welding .....	2-5
Wiring diagram:	
Engine .....	3-53
Generator regulator .....	3-96
Hull .....	3-55, 3-56
Indicator panel .....	3-77
Personnel heater .....	3-139
Winterization heater .....	3-188

**By Order of the Secretary of the Army:**

BERNARD W. ROGERS  
General, United States Army  
Chief of Staff

Official:

J. C. PENNINGTON  
Brigadier General, United States Army  
The Adjutant General

Distribution:

To be distributed in accordance with DA Form 12-37 Direct and General requirements for AR/AAV M551, M551A1, Full Tracked, 152MM.

\* U.S. GOVERNMENT PRINTING OFFICE : 1988 0 - 201-421 (80129)



FILL IN YOUR  
UNIT'S ADDRESS

DEPARTMENT OF THE ARMY

FOLD BACK

POSTAGE AND FEES PAID  
DEPARTMENT OF THE ARMY  
DOD 314



OFFICIAL BUSINESS  
PENALTY FOR PRIVATE USE \$300

Commander  
US Army Tank-Automotive Materiel  
Readiness Command  
ATTN: DRSTA-MBA  
Warren, MI 48090

ALONG DOTTED LINE

FOLD BACK



THEN... JOT DOWN THE DOPE ABOUT IT ON THIS FORM, CUT IT OUT, FOLD IT AND DROP IT IN THE MAIL!

# SOMETHING WRONG WITH THIS MANUAL?

FROM: (YOUR UNIT'S COMPLETE ADDRESS)

DATE

PUBLICATION NUMBER

DATE

TM 9-2350-230-34-1

BE EXACT... PIN-POINT WHERE IT IS

IN THIS SPACE TELL WHAT IS WRONG AND WHAT SHOULD BE DONE ABOUT IT:

PAGE NO.	PARA-GRAPH	FIGURE NO.	TABLE NO.
----------	------------	------------	-----------

LINE

CUT ALONG

TYPED NAME, GRADE OR TITLE, AND TELEPHONE NUMBER

SIGN HERE



FILL IN YOUR  
UNIT'S ADDRESS

FOLD BACK

DEPARTMENT OF THE ARMY

\_\_\_\_\_  
\_\_\_\_\_

OFFICIAL BUSINESS  
PENALTY FOR PRIVATE USE \$300

POSTAGE AND FEES PAID  
DEPARTMENT OF THE ARMY  
DOD 314



Commander  
US Army Tank-Automotive Materiel  
Readiness Command  
ATTN: DRSTA-MBA  
Warren, MI 48090

CUT ALONG DOTTED LINE

FOLD BACK



FILL IN YOUR  
UNIT'S ADDRESS



FOLD BACK

DEPARTMENT OF THE ARMY

\_\_\_\_\_  
\_\_\_\_\_

OFFICIAL BUSINESS  
PENALTY FOR PRIVATE USE \$300

POSTAGE AND FEES PAID  
DEPARTMENT OF THE ARMY  
DOD 314



Commander  
US Army Tank-Automotive Materiel  
Readiness Command  
ATTN: DRSTA-MBA  
Warren, MI 48090

T ALONG DOTTED LINE

FOLD BACK

## THE METRIC SYSTEM AND EQUIVALENTS

### LINEAR MEASURE

1 Centimeter = 10 Millimeters = 0.01 Meters = 0.3937 Inches  
 1 Meter = 100 Centimeters = 1000 Millimeters = 39.37 Inches  
 1 Kilometer = 1000 Meters = 0.621 Miles

### SQUARE MEASURE

1 Sq Centimeter = 100 Sq Millimeters = 0.155 Sq Inches  
 1 Sq Meter = 10,000 Sq Centimeters = 10.76 Sq Feet  
 1 Sq Kilometer = 1,000,000 Sq Meters = 0.386 Sq Miles

### WEIGHTS

1 Gram = 0.001 Kilograms = 1000 Milligrams = 0.035 Ounces  
 1 Kilogram = 1000 Grams = 2.2 Lb  
 1 Metric Ton = 1000 Kilograms = 1 Megagram = 1.1 Short Tons

### CUBIC MEASURE

1 Cu Centimeter = 1000 Cu Millimeters = 0.06 Cu Inches  
 1 Cu Meter = 1,000,000 Cu Centimeters = 35.31 Cu Feet

### LIQUID MEASURE

1 Milliliter = 0.001 Liters = 0.0338 Fluid Ounces  
 1 Liter = 1000 Milliliters = 33.82 Fluid Ounces

### TEMPERATURE

$5 \text{ } ^\circ\text{F} - 32 = ^\circ\text{C}$   
 212<sup>o</sup> Fahrenheit is equivalent to 100<sup>o</sup> Celsius  
 90<sup>o</sup> Fahrenheit is equivalent to 32.2<sup>o</sup> Celsius  
 32<sup>o</sup> Fahrenheit is equivalent to 0<sup>o</sup> Celsius  
 $9 \text{ } ^\circ\text{C} + 32 = \text{ } ^\circ\text{F}$

### APPROXIMATE CONVERSION FACTORS

TO CHANGE	TO	MULTIPLY BY
Inches . . . . .	Centimeters . . . . .	2.540
Feet . . . . .	Meters . . . . .	0.305
Yards . . . . .	Meters . . . . .	0.914
Miles . . . . .	Kilometers . . . . .	1.609
Square Inches . . . . .	Square Centimeters . . . . .	6.451
Square Feet . . . . .	Square Meters . . . . .	0.093
Square Yards . . . . .	Square Meters . . . . .	0.836
Square Miles . . . . .	Square Kilometers . . . . .	2.590
Acres . . . . .	Square Hectometers . . . . .	0.405
Cubic Feet . . . . .	Cubic Meters . . . . .	0.028
Cubic Yards . . . . .	Cubic Meters . . . . .	0.765
Fluid Ounces . . . . .	Milliliters . . . . .	29.573
Pints . . . . .	Liters . . . . .	0.473
Quarts . . . . .	Liters . . . . .	0.946
Gallons . . . . .	Liters . . . . .	3.785
Ounces . . . . .	Grams . . . . .	28.349
Pounds . . . . .	Kilograms . . . . .	0.454
Short Tons . . . . .	Metric Tons . . . . .	0.907
Pound-Feet . . . . .	Newton-Meters . . . . .	1.356
Pounds per Square Inch . . . . .	Kilopascals . . . . .	6.895
Miles per Gallon . . . . .	Kilometers per Liter . . . . .	0.425
Miles per Hour . . . . .	Kilometers per Hour . . . . .	1.609

TO CHANGE	TO	MULTIPLY BY
Centimeters . . . . .	Inches . . . . .	0.394
Meters . . . . .	Feet . . . . .	3.280
Meters . . . . .	Yards . . . . .	1.094
Kilometers . . . . .	Miles . . . . .	0.621
Square Centimeters . . . . .	Square Inches . . . . .	0.155
Square Meters . . . . .	Square Feet . . . . .	10.764
Square Meters . . . . .	Square Yards . . . . .	1.196
Square Kilometers . . . . .	Square Miles . . . . .	0.386
Square Hectometers . . . . .	Acres . . . . .	2.471
Cubic Meters . . . . .	Cubic Feet . . . . .	35.315
Cubic Meters . . . . .	Cubic Yards . . . . .	1.308
Milliliters . . . . .	Fluid Ounces . . . . .	0.034
Liters . . . . .	Pints . . . . .	2.113
Liters . . . . .	Quarts . . . . .	1.057
Liters . . . . .	Gallons . . . . .	0.264
Grams . . . . .	Ounces . . . . .	0.035
Kilograms . . . . .	Pounds . . . . .	2.205
Metric Tons . . . . .	Short Tons . . . . .	1.102
Newton-Meters . . . . .	Pound-Feet . . . . .	0.738
Kilopascals . . . . .	Pounds per Square Inch . . . . .	0.145
Kilometers per Liter . . . . .	Miles per Gallon . . . . .	2.354
Kilometers per Hour . . . . .	Miles per Hour . . . . .	0.621

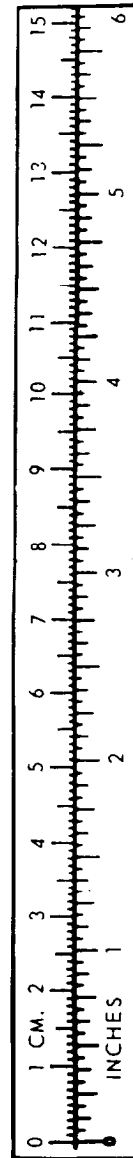

TA089991



This fine document...

Was brought to you by me:



## [Liberated Manuals -- free army and government manuals](#)

Why do I do it? I am tired of sleazy CD-ROM sellers, who take publicly available information, slap “watermarks” and other junk on it, and sell it. Those masters of search engine manipulation make sure that their sites that sell free information, come up first in search engines. They did not create it... They did not even scan it... Why should they get your money? Why are not letting you give those free manuals to your friends?

I am setting this document FREE. This document was made by the US Government and is NOT protected by Copyright. Feel free to share, republish, sell and so on.

I am not asking you for donations, fees or handouts. If you can, please provide a link to [liberatedmanuals.com](http://liberatedmanuals.com), so that free manuals come up first in search engines:

<A HREF=<http://www.liberatedmanuals.com/>>Free Military and Government Manuals</A>

- Sincerely  
Igor Chudov  
<http://igor.chudov.com/>
- [Chicago Machinery Movers](#)